

# Switched Mode Controller for DC Motor Drive

## FEATURES

- Single or Dual Supply Operation
- $\pm 2.5\text{V}$  to  $\pm 20\text{V}$  Input Supply Range
- $\pm 5\%$  Initial Oscillator Accuracy;  $\pm 10\%$  Over Temperature
- Pulse-by-Pulse Current Limiting
- Under-Voltage Lockout
- Shutdown Input with Temperature Compensated 2.5V Threshold
- Uncommitted PWM Comparators for Design Flexibility
- Dual 100mA, Source/Sink Output Drivers

## DESCRIPTION

The UC1637 is a pulse width modulator circuit intended to be used for a variety of PWM motor drive and amplifier applications requiring either uni-directional or bi-directional drive circuits. When used to replace conventional drivers, this circuit can increase efficiency and reduce component costs for many applications. All necessary circuitry is included to generate an analog error signal and modulate two bi-directional pulse train outputs in proportion to the error signal magnitude and polarity.

This monolithic device contains a sawtooth oscillator, error amplifier, and two PWM comparators with  $\pm 100\text{mA}$  output stages as standard features. Protection circuitry includes under-voltage lockout, pulse-by-pulse current limiting, and a shutdown port with a 2.5V temperature compensated threshold.

The UC1637 is characterized for operation over the full military temperature range of  $-55^\circ\text{C}$  to  $+125^\circ\text{C}$ , while the UC2637 and UC3637 are characterized for  $-25^\circ\text{C}$  to  $+85^\circ\text{C}$  and  $0^\circ\text{C}$  to  $+70^\circ\text{C}$ , respectively.

## ABSOLUTE MAXIMUM RATINGS (Note 1)

Supply Voltage ( $\pm V_s$ )	$\pm 20\text{V}$
Output Current, Source/Sink (Pins 4, 7)	500mA
Analog Inputs (Pins 1, 2, 3, 8, 9, 10, 11, 12, 13, 14, 15, 16)	$\pm V_s$
Error Amplifier Output Current (Pin 17)	$\pm 20\text{mA}$
Oscillator Charging Current (Pin 18)	-2mA
Power Dissipation at $T_A = 25^\circ\text{C}$ (Note 2)	1000mW
Power Dissipation at $T_c = 25^\circ\text{C}$ (Note 2)	2000mW
Storage Temperature Range	$-65^\circ\text{C}$ to $+150^\circ\text{C}$
Lead Temperature (Soldering, 10 Seconds)	$+300^\circ\text{C}$

Note 1: Currents are positive into, negative out of the specified terminal.

Note 2: Consult Packaging Section of Databook for thermal limitations and considerations of package.

## BLOCK DIAGRAM

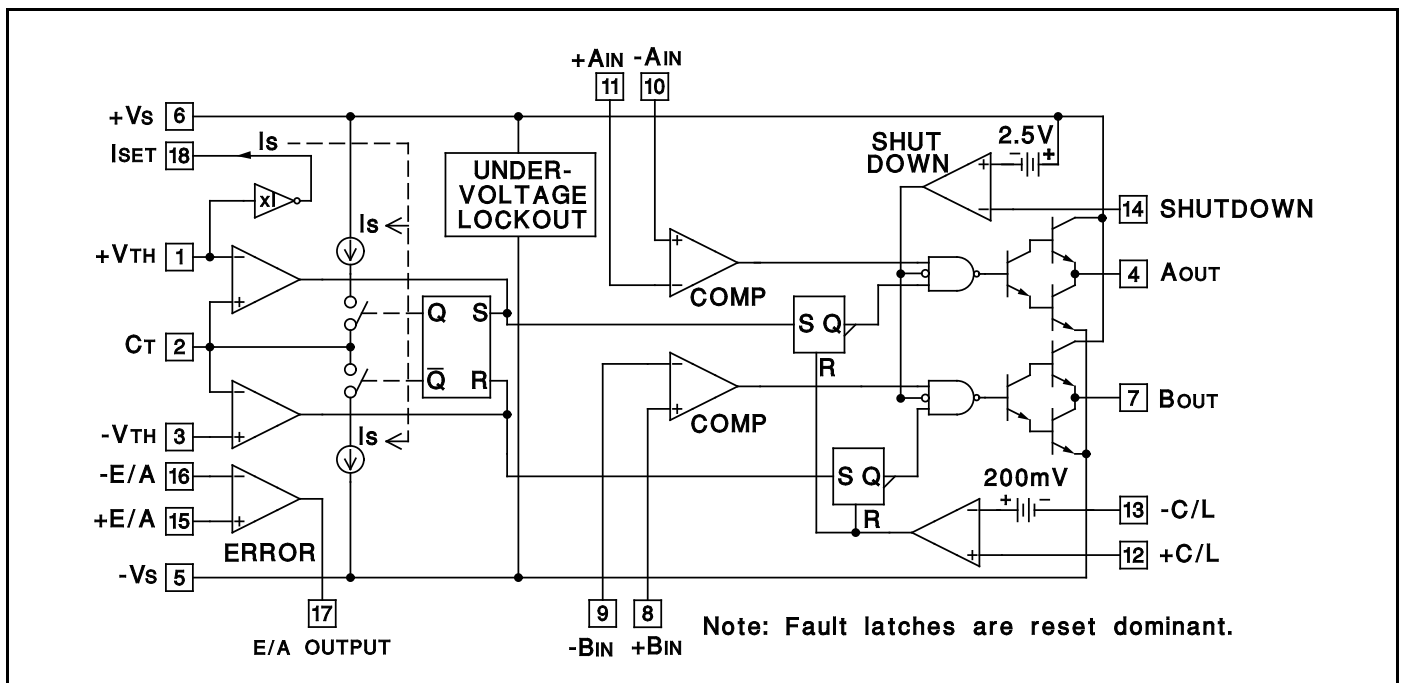

CONNECTION DIAGRAM

DIL-18 (TOP VIEW)

J or N Package

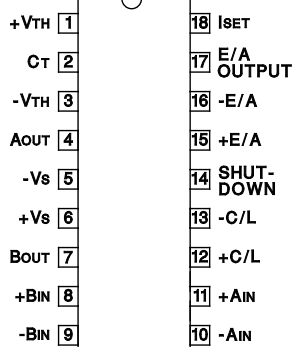

PLCC-20, LCC-20

(TOP VIEW)

Q, L Packages

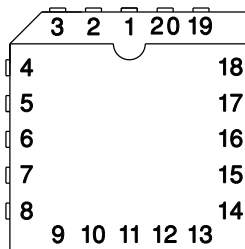

PACKAGE PIN FUNCTION	
FUNCTION	PIN
+VTH	1
CT	2
-VTH	3
AOUT	4
-Vs	5
N/C	6
+Vs	7
BOUT	8
+BIN	9
-BIN	10
-AIN	11
+AIN	12
+C/L	13
-C/L	14
SHUTDOWN	15
N/C	16
+E/A	17
-E/A	18
E/A OUTPUT	19
ISET	20

SOIC-20 (TOP VIEW)

DW Package

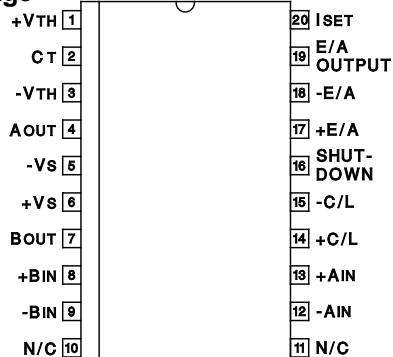

**ELECTRICAL CHARACTERISTICS:** Unless otherwise stated, these specifications apply for TA = -55°C to +125°C for the UC1637; -25°C to +85°C for the UC2637; and 0°C to +70°C for the UC3637; +Vs = +15V, -Vs = -15V, +VTH = 5V, -VTH = -5V, RT = 16.7kΩ, CT = 1500pF, TA=TJ.

PARAMETER	TEST CONDITIONS	UC1637/UC2637			UC3637			UNITS
		MIN	TYP	MAX	MIN	TYP	MAX	
<b>Oscillator</b>								
Initial Accuracy	TJ = 25°C (Note 6)	9.4	10	10.6	9	10	11	kHz
Voltage Stability	Vs = ±5V to ±20V, VPIN 1 = 3V, VPIN 3 = -3V		5	7		5	7	%
Temperature Stability	Over Operating Range (Note 3)		0.5	2		0.5	2	%
+VTH Input Bias Current	VPIN 2 = 6V	-10	0.1	10	-10	0.1	10	μA
-VTH Input Bias Current	VPIN 2 = 0V	-10	-0.5		-10	-0.5		μA
+VTH, -VTH Input Range		+Vs-2		-Vs+2	+Vs-2		-Vs+2	V
<b>Error Amplifier</b>								
Input Offset Voltage	VCM = 0V		1.5	5		1.5	10	mV
Input Bias Current	VCM = 0V		0.5	5		0.5	5	μA
Input Offset Current	VCM = 0V		0.1	1		0.1	1	μA
Common Mode Range	Vs = ±2.5 to 20V	-Vs+2		+Vs	-Vs+2		+Vs	V
Open Loop Voltage Gain	RL = 10k	75	100		80	100		dB
Slew Rate			15			15		V/μs
Unity Gain Bandwidth			2			2		MHz
CMRR	Over Common Mode Range	75	100		75	100		dB
PSRR	Vs = ±2.5 to ±20V	75	110		75	110		dB

**ELECTRICAL CHARACTERISTICS:** Unless otherwise stated, these specifications apply for  $T_A = -55^{\circ}\text{C}$  to  $+125^{\circ}\text{C}$  for the UC1637;  $-25^{\circ}\text{C}$  to  $+85^{\circ}\text{C}$  for the UC2637; and  $0^{\circ}\text{C}$  to  $+70^{\circ}\text{C}$  for the UC3637:  $V_S = +15\text{V}$ ,  $-V_S = -15\text{V}$ ,  $+V_{TH} = 5\text{V}$ ,  $-V_{TH} = -5\text{V}$ ,  $R_T = 16.7\text{k}\Omega$ ,  $C_T = 1500\text{pF}$ ,  $T_A = T_J$ .

PARAMETERS	TEST CONDITIONS	UC1637/UC2637			UC3637			UNITS
		MIN	TYP	MAX	MIN	TYP	MAX	
<b>Error Amplifier (Continued)</b>								
Output Sink Current	$V_{PIN\ 17} = 0\text{V}$		-50	-20		-50	-20	mA
Output Source Current	$V_{PIN\ 17} = 0\text{V}$	5	11		5	11		mA
High Level Output Voltage		13	13.6		13	13.6		V
Low Level Output Voltage			-14.8	-13		-14.8	-13	V
<b>PWM Comparators</b>								
Input Offset Voltage	$V_{CM} = 0\text{V}$		20			20		mV
Input Bias Current	$V_{CM} = 0\text{V}$		2	10		2	10	$\mu\text{A}$
Input Hysteresis	$V_{CM} = 0\text{V}$		10			10		mV
Common Mode range	$V_S = \pm 5\text{V}$ to $\pm 20\text{V}$	$-V_S + 1$		$+V_S - 2$	$-V_S + 1$		$+V_S - 2$	V
<b>Current Limit</b>								
Input Offset Voltage	$V_{CM} = 0\text{V}$ , $T_J = 25^{\circ}\text{C}$	190	200	210	180	200	220	mV
Input Offset Voltage T.C.			-0.2			-0.2		$\text{mV}/^{\circ}\text{C}$
Input Bias Current		-10	-1.5		-10	-1.5		$\mu\text{A}$
Common Mode Range	$V_S = \pm 2.5\text{V}$ to $\pm 20\text{V}$	$-V_S$		$+V_S - 3$	$-V_S$		$+V_S - 3$	V
<b>Shutdown</b>								
Shutdown Threshold	(Note 4)	-2.3	-2.5	-2.7	-2.3	-2.5	-2.7	V
Hysteresis			40			40		mV
Input Bias Current	$V_{PIN\ 14} = +V_S$ to $-V_S$	-10	-0.5		-10	-0.5		$\mu\text{A}$
<b>Under-Voltage Lockout</b>								
Start Threshold	(Note 5)		4.15	5.0		4.15	5.0	V
Hysteresis			0.25			0.25		mV
<b>Total Standby Current</b>								
Supply Current			8.5	15		8.5	15	mA
<b>Output Section</b>								
Output Low Level	$I_{SINK} = 20\text{mA}$		-14.9	-13		-14.9	-13	V
	$I_{SINK} = 100\text{mA}$		-14.5	-13		-14.5	-13	V
Output High Level	$I_{SOURCE} = 20\text{mA}$	13	13.5		13	13.5		V
	$I_{SOURCE} = 100\text{mA}$	12	13.5		12	13.5		V
Rise Time	(Note 3) $C_L = \text{Inf}$ , $T_J = 25^{\circ}\text{C}$		100	600		100	600	ns
Fall Time	(Note 3) $C_L = \text{Inf}$ , $T_J = 25^{\circ}\text{C}$		100	300		100	300	ns

Note 3: These parameters, although guaranteed over the recommended operating conditions, are not 100% tested in production.

Note 4: Parameter measured with respect to  $+V_S$  (Pin 6).

Note 5: Parameter measured at  $+V_S$  (Pin 6) with respect to  $-V_S$  (Pin 5).

Note 6:  $R_T$  and  $C_T$  referenced to Ground.

## FUNCTIONAL DESCRIPTION

Following is a description of each of the functional blocks shown in the Block Diagram.

### Oscillator

The oscillator consists of two comparators, a charging and discharging current source, a current source set terminal,  $I_{SET}$  and a flip-flop. The upper and lower threshold of the oscillator waveform is set externally by applying a voltage at pins  $+V_{TH}$  and  $-V_{TH}$  respectively. The  $+V_{TH}$  ter-

minal voltage is buffered internally and also applied to the  $I_{SET}$  terminal to develop the capacitor charging current through  $R_T$ . If  $R_T$  is referenced to  $-V_S$  as shown in Figure 1, both the threshold voltage and charging current will vary proportionally to the supply differential, and the oscillator frequency will remain constant. The triangle waveform oscillators frequency and voltage amplitude is determined by the external components using the formulas given in Figure 1.

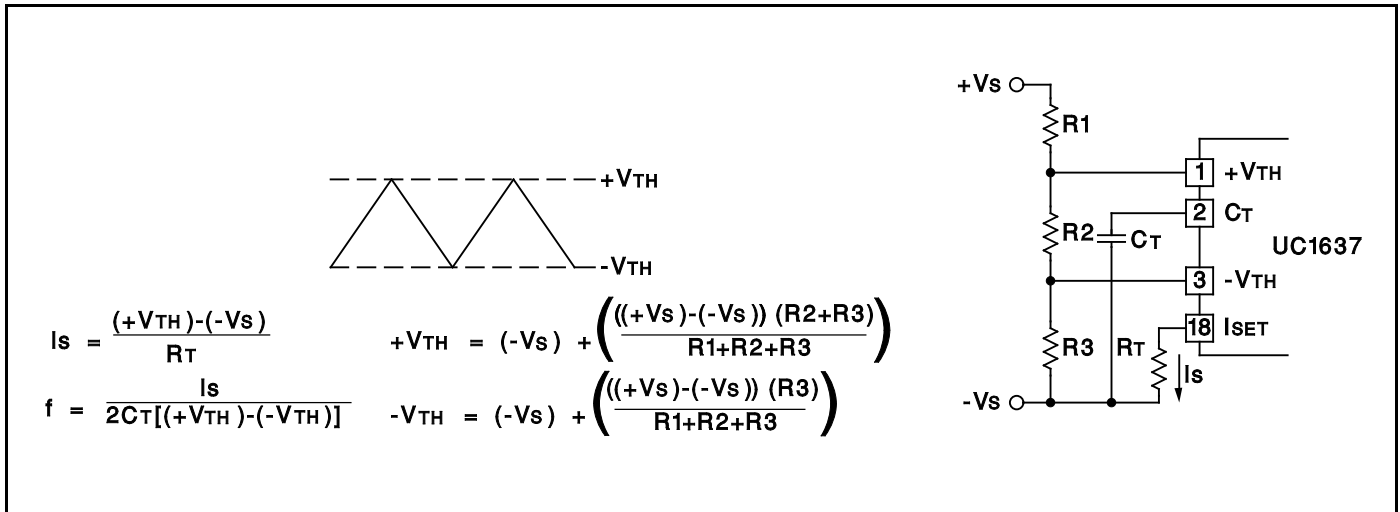

Figure 1. Oscillator Setup

**PWM Comparators**

Two comparators are provided to perform pulse width modulation for each of the output drivers. Inputs are uncommitted to allow maximum flexibility. The pulse width of the outputs A and B is a function of the sign and amplitude of the error signal. A negative signal at Pin 10 and 8 will lengthen the high state of output A and shorten the high state of output B. Likewise, a positive error signal reverses the procedure. Typically, the oscillator waveform is compared against the summation of the error signal and the level set on Pin 9 and 11.

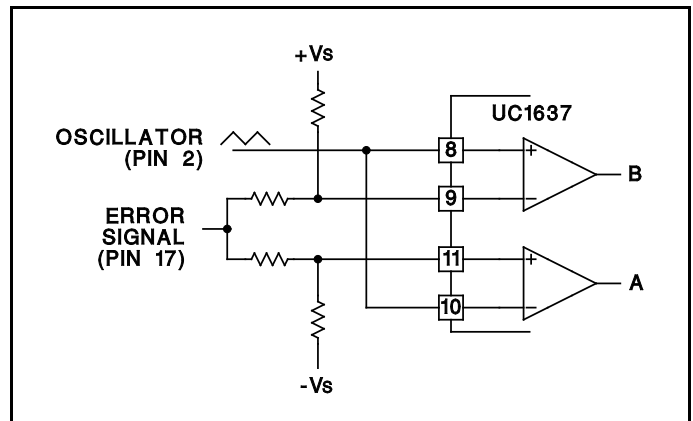

Figure 2. Comparator Biasing

**MODULATION SCHEMES**

**Case A Zero Deadtime** (Equal voltage on Pin 9 and Pin 11)

In this configuration, maximum holding torque or stiffness and position accuracy is achieved. However, the power input into the motor is increased. Figure 3A shows this configuration.

**Case B Small Deadtime** (Voltage on Pin 9 > Pin 11)

A small differential voltage between Pin 9 and 11 provides the necessary time delay to reduce the chances of momentary short circuit in the output stage during transitions, especially where power-amplifiers are used. Refer to Figure 3B.

**Case C Increased Deadtime and Deadband Mode**

(Voltage on Pin 9 > Pin 11)

With the reduction of stiffness and position accuracy, the power input into the motor around the null point of the servo loop can be reduced or eliminated by widening the window of the comparator circuit to a degree of acceptance. Where position accuracy and mechanical stiffness is unimportant, deadband operation can be used. This is shown in Figure 3C.

**Output Drivers**

Each output driver is capable of both sourcing and sinking 100mA steady state and up to 500mA on a pulsed basis for rapid switching of either POWERFET or bipolar transistors. Output levels are typically -Vs + 0.2V @50mA low level and +Vs - 2.0V @50mA high level.

**Error Amplifier**

The error amplifier consists of a high slew rate (15V/μs) op-amp with a typical 1MHz bandwidth and low output impedance. Depending on the ±Vs supply voltage, the common mode input range and the voltage output swing is within 2V of the Vs supply.

**Under-Voltage Lockout**

An under-voltage lockout circuit holds the outputs in the low state until a minimum of 4V is reached. At this point, all internal circuitry is functional and the output drivers are enabled. If external circuitry requires a higher starting voltage, an over-riding voltage can be programmed through the shutdown terminal as shown in Figure 4.

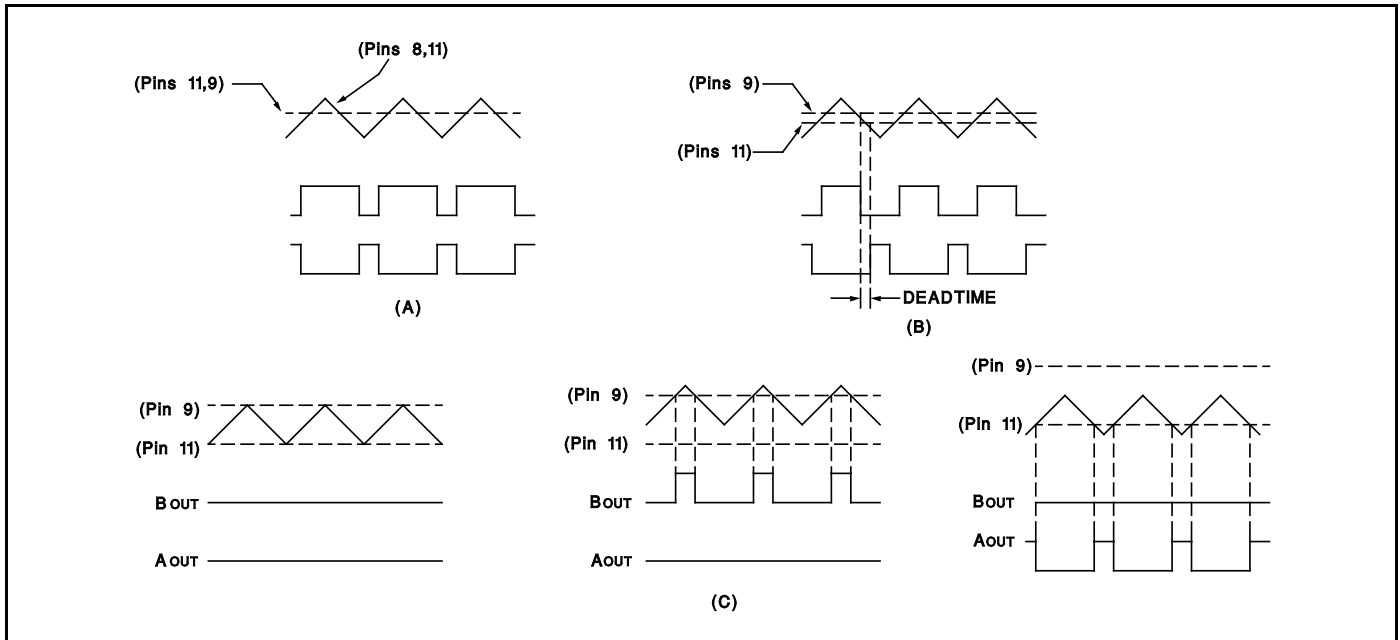

**Figure 3.** Modulation Schemes Showing (A) Zero Deadtime (B) Deadtime and (C) Deadband Configurations

### Shutdown Comparator

The shutdown terminal may be used for implementing various shutdown and protection schemes. By pulling the terminal more than 2.5V below  $V_{IN}$ , the output drivers will be enabled. This can be realized using an open collector gate or NPN transistor biased to either ground or the negative supply. Since the threshold is temperature stabilized, the comparator can be used as an accurate low voltage lockout (Figure 4) and/or delayed start as in Figure 5. In the shutdown mode the outputs are held in the low state.

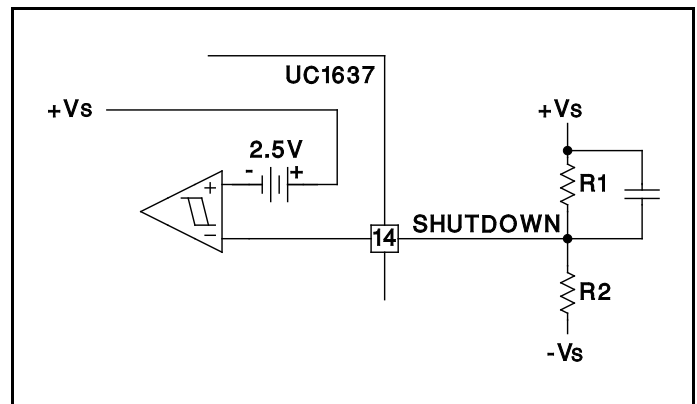

**Figure 5.** Delayed Start-Up

$-V_s$  to within 3V of the  $+V_s$  supply while providing excellent noise rejection. Figure 6 shows a typical current sense circuit.

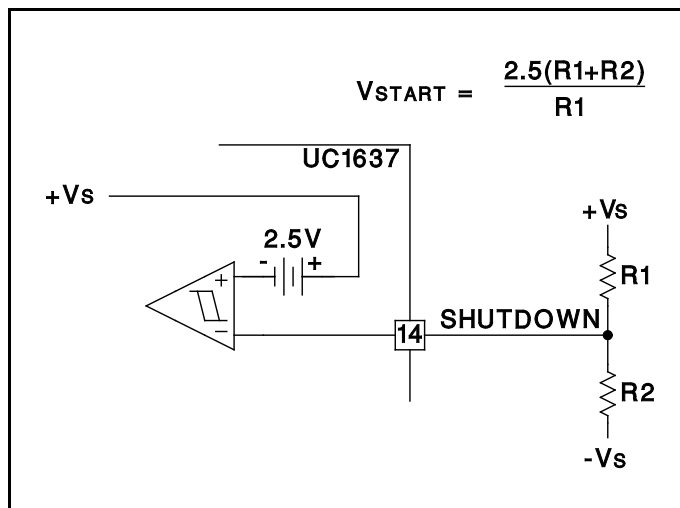

**Figure 4.** External Under-Voltage Lockout

### Current Limit

A latched current limit amplifier with an internal 200mV offset is provided to allow pulse-by-pulse current limiting. Differential inputs will accept common mode signals from

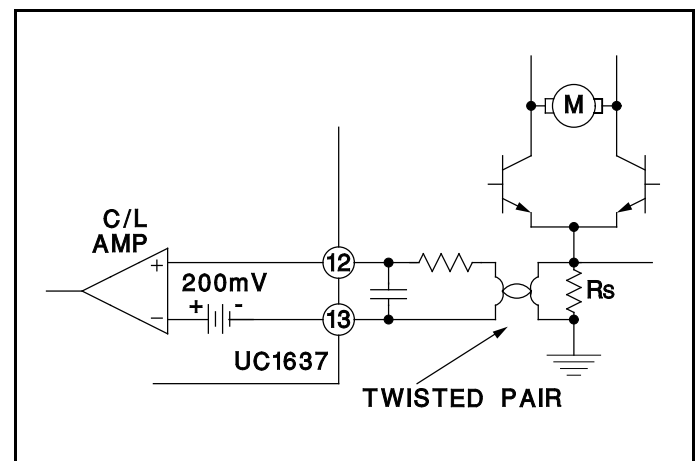

**Figure 6.** Current Limit Sensing

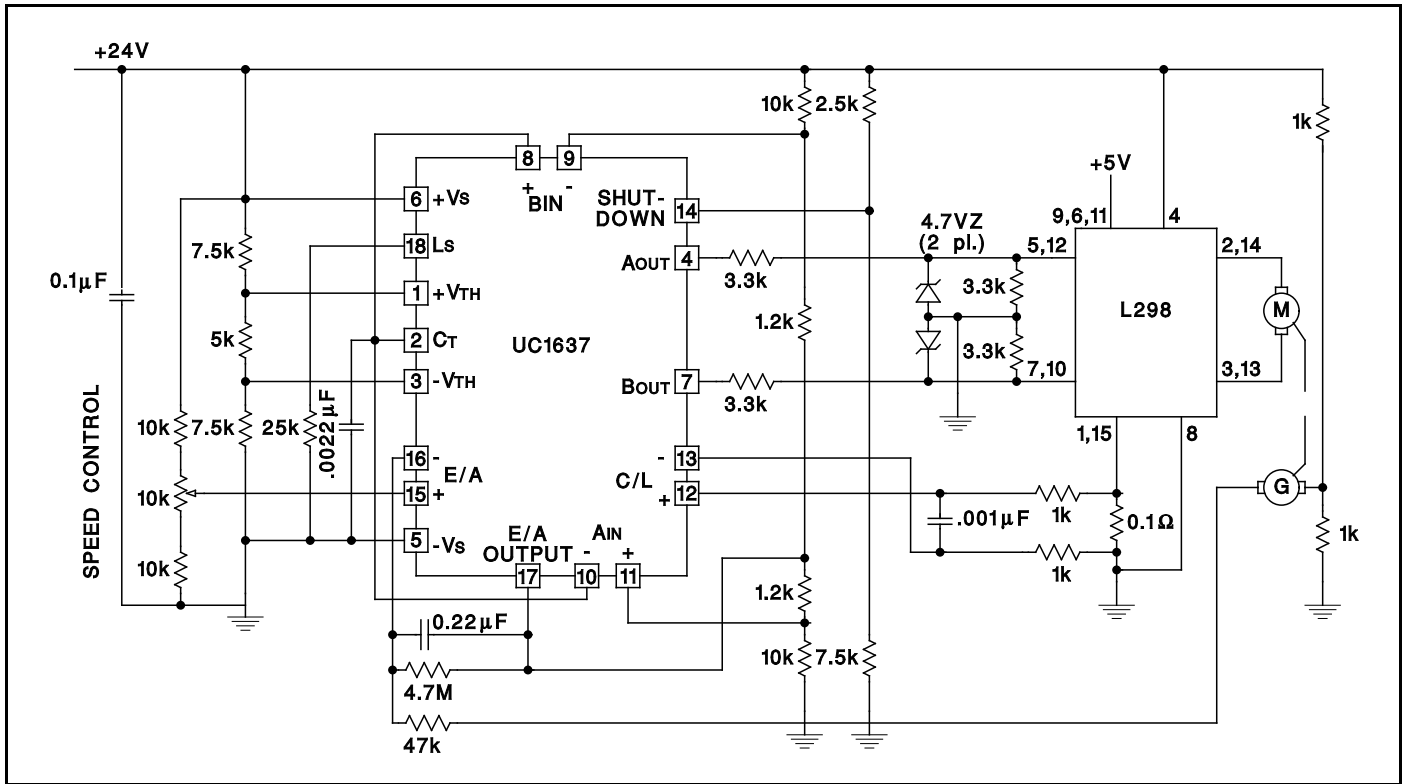

Figure 7. Bi-Directional Motor Drive with Speed Control Power-Amplifier

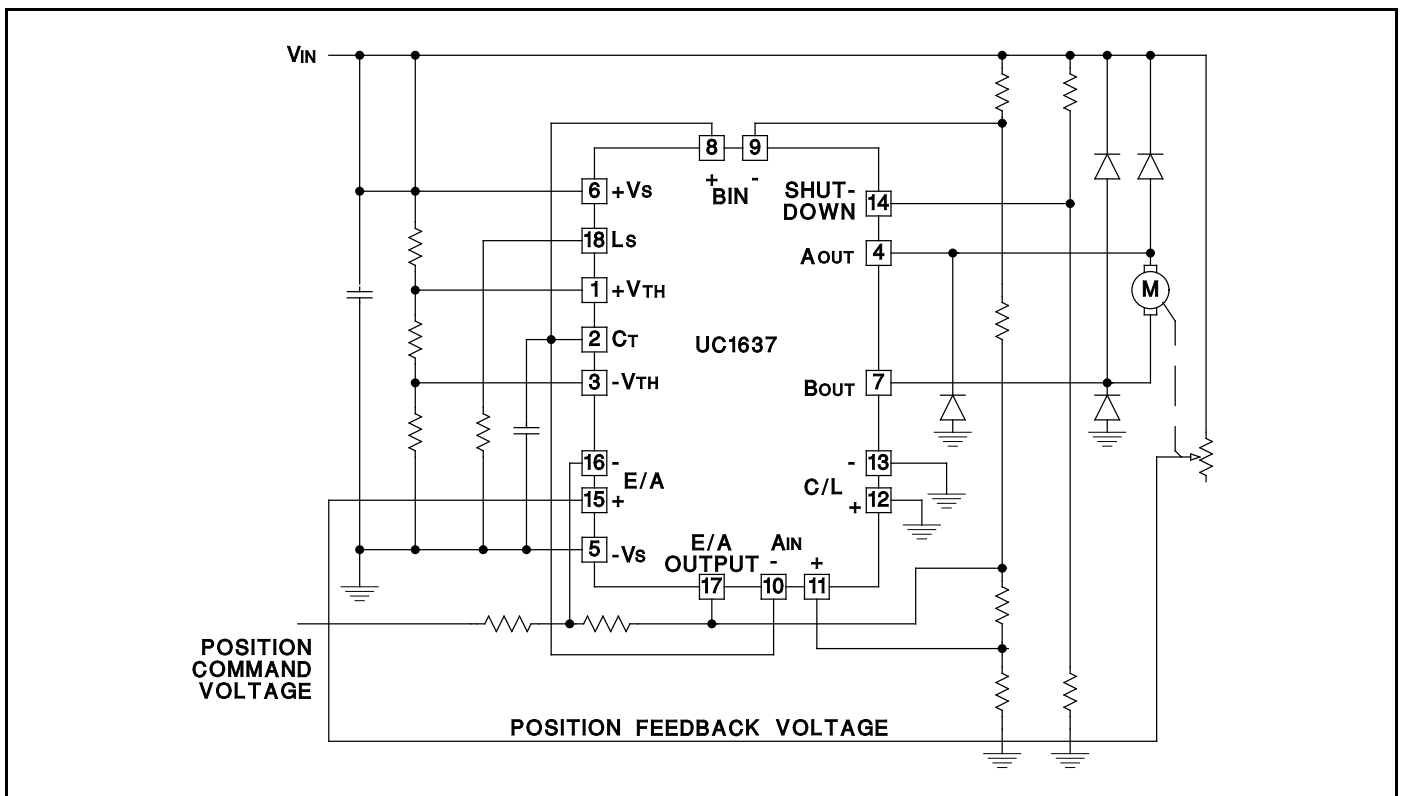

Figure 8. Single Supply Position Servo Motor Drive