

Design Idea DI-8

TinySwitch™

Cellular Phone Adapter



Application	Device	Power Output	Input Voltage	Output Voltage	Topology
Cellular Phone	TNY254	3.6 W	85 - 265 VAC	5.2 V ± 6%	Flyback

Design Highlights

- Constant current - constant voltage output
- Very low no-load power consumption (<100 mW @ 230 VAC)
- Lower cost than RCC converter and other solutions
- Universal input: 85 - 265 VAC
- Low component count
- Simple, two winding transformer

Operation

The *TinySwitch* flyback converter generates a regulated voltage and controlled current limit for charging cellular telephone batteries (Li-Ion, NiMH, NiCd).

In the example shown C1, L1, R1 and C2 filter the input rectified AC providing smoothed DC voltage for the converter.

These components also provide the necessary filtering to meet conducted EMI requirements.

Diode D5 with C5, L2 and C6, rectify and filter the output from the secondary. The reference Zener diode VR1 and the LED of optocoupler U2 sense the output voltage and provide feedback to the *TinySwitch*. The output voltage is set by the combined voltage drops of U2, VR1 and R7. Q1, R3, R4, R5 and R6 provide the constant output current function. When the drop across R4 and R5 reaches ~0.6 V, Q1 activates the optocoupler U2 to inhibit the *TinySwitch*.

Diode D6, R2, and C4 form a clamp network to dissipate the energy from the leakage inductance of the transformer. The component values are chosen to limit the DRAIN voltage to less than 650 V at high line and full load.

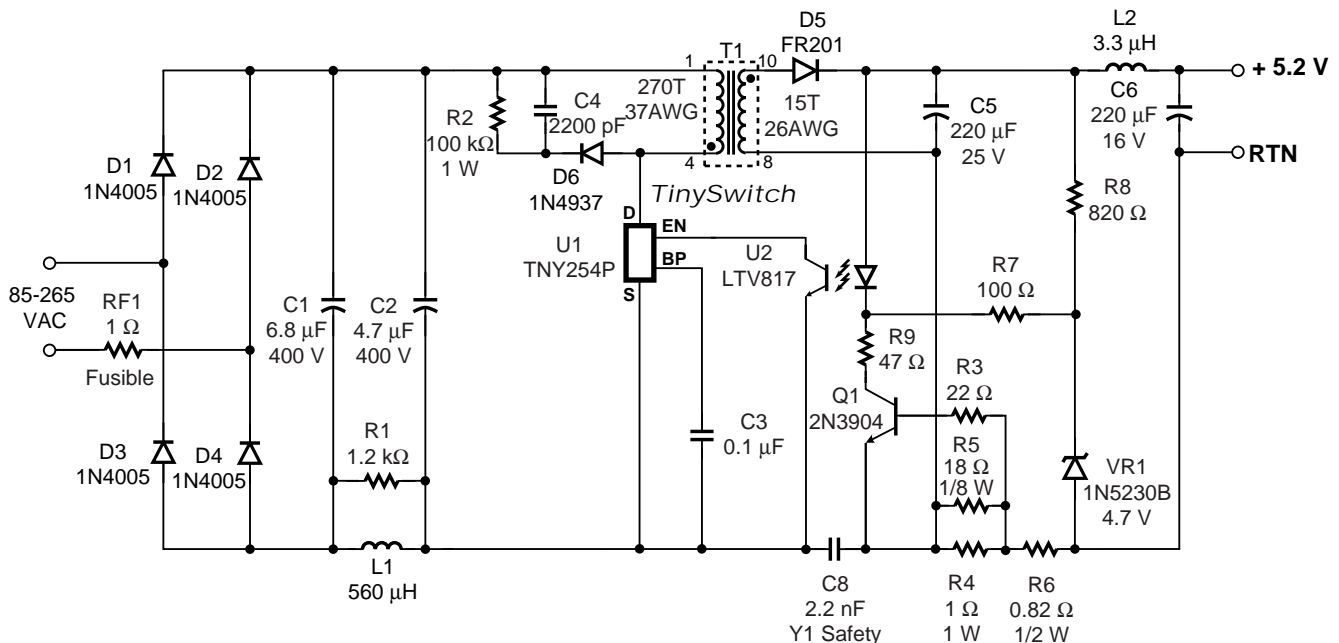

Figure 1. *TinySwitch* Cellular Phone Adapter.

PI-2295-090198

Key Design Points

- To adjust the current limit (I_{CL}), adjust the value of the parallel combination of R4 and R5. The V_{be} of Q1 divided by the desired current equals this value.
- Choose a power rating for R4 at least twice $I_{CL}^2 \times R4$. Use R5 to adjust for the increments between standard values for R4.
- Choose R6 such that the drop across the parallel combination R4-R5 and R6 is at least 1.0V at I_{CL} . This will keep the short circuit output current constant at I_{CL} .
- Choose any general purpose silicon NPN transistor for Q1.
- Choose a fast recovery type rectifier for D5. It must have a reverse recovery time less than 150 ns. Its average current rating should be at least three times I_{CL} . A Schottky type may be used to improve efficiency.
- To improve output voltage accuracy a precision reference may be used in place of VR1. In the circuit shown the Zener is operated below its specified Zener current to reduce standby power. Increasing this current by lowering the value of R8 will also improve accuracy.
- Efficiency can be significantly improved by employing current sense techniques with lower voltage thresholds.

Transformer Parameters	
Core Material	TDK PC40EE16-Z A_L of 70 nH/T ²
Bobbin	EE16 10 pin (Ying Chin YC1607 or equivalent)
Winding Order	Primary (4-1), Secondary (10-8) [triple insulated secondary]
Primary Inductance	5.2 mH \pm 10%
Primary Resonant Frequency	375 kHz minimum
Leakage Inductance	250 μ H maximum

Table 1. Transformer Design Parameters.

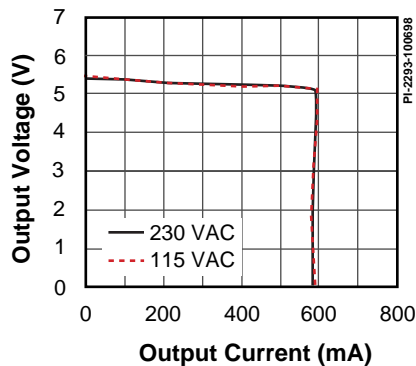

Figure 2. Typical Performance at the end of 6 ft. (1.8 m) cable.

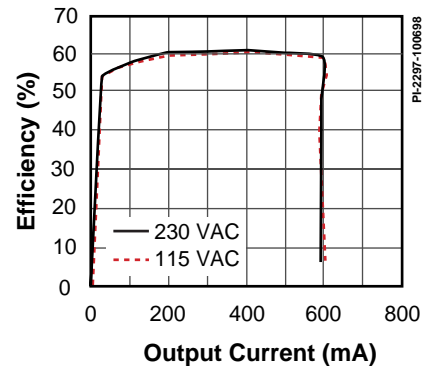

Figure 3. Efficiency vs Output Current.

For the latest updates, visit our website: www.powerint.com

Power Integrations reserves the right to make changes to its products at any time to improve reliability or manufacturability. Power Integrations does not assume any liability arising from the use of any device or circuit described herein, nor does it convey any license under its patent rights or the rights of others.

PI Logo and *TOPSwitch* are registered trademarks of Power Integrations, Inc.

©Copyright 1998, Power Integrations, Inc. 477 N. Mathilda Avenue, Sunnyvale, CA 94086

WORLD HEADQUARTERS

Power Integrations, Inc.
477 N. Mathilda Avenue
Sunnyvale, CA 94086 USA
Phone: +1•408•523•9265
Fax: +1•408•523•9365

AMERICAS - EAST

Power Integrations
Marietta, Georgia
Phone: +1•770•424•5152
Fax: +1•770•424•6567

EUROPE & AFRICA

Power Integrations (Europe) Ltd.
United Kingdom
Phone: +44•1753•622•208
Fax: +44•1753•622•209

TAIWAN

Power Integrations International
Taipei
Phone: +886•2•2727•1221
Fax: +886•2•2727•1223

KOREA

Power Integrations International
Seoul
Phone: +82•2•568•7520
Fax: +82•2•568•7474

JAPAN

Power Integrations, K.K.
Yokohama-shi
Phone: +81•45•471•1021
Fax: +81•45•471•3717

INDIA (Technical Support)

Innovatech
Bangalore
Phone: +91•80•226•6023
Fax: +91•80•228•2191