

Hybrid and Electric Vehicle Solutions Guide

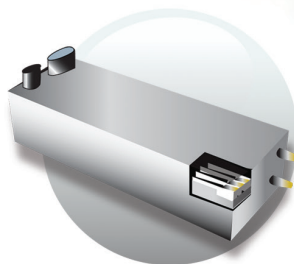

Battery

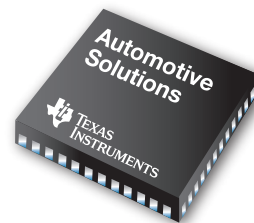

Infrastructure

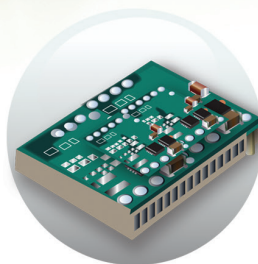

Inverter

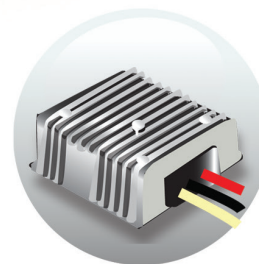

DC/DC

System Solutions for Hybrid and Electric Vehicles

Table of Contents

System Solutions for Hybrid and Electric Vehicles

3	Texas Instruments in Automotive Applications
3	Introduction to Electric Transportation
4	Why TI?
4	System Architecture of HEV/EV

Battery Management

5	Introduction to Battery Management
6	Battery Management Systems
7	Battery Management: Applications
7	bq76PL536A-Q1 Stackable Monitor, Protector and Balancer for Three- to Six-Series Li-Ion Cells
7	bq76PL536A Evaluation Module

Power Conversion Systems

8	Introduction to Power Conversion
9	DC/DC Converter Using UCC2895-Q1
10	DC/DC Converter Using C2000™ Piccolo™ MCUs
10	C2000™ Piccolo™ F2802x Family
11	C2000™ Digital Power DC/DC Developer Kits

Charging and Charging Infrastructure

12	Introduction to Charging and Charging Infrastructure
13	AFE031 Integrated PLC Analog Front End
13	PLC Developer Kit
13	TI PLC Modem Development Kit (TI PLC DK)
14	Charging Systems – AC Levels 1 and 2 (Onboard)
15	Charging Systems – DC Level 3 (Offboard)
16	AC/DC Converter with PFC using C2000™ Piccolo™ MCUs
16-17	AC/DC Development Kits with C2000™ MCUs
17	Why Piccolo™ MCUs?
18	Piccolo™ MCUs F2802x vs. F2803x
18	ControlSuite™ Software
19	Power Factor Correction with UCC
19	UCC28070-Q1 Two-Phase Interleaved Constant-
19	Current-Mode (CCM) Power Factor

Motor Control

20	Introduction to Drive and Motor Control
21	Safe Motor Control with TMS570 ARM® Cortex™-R4F
22	Safe Motor Drive with DRV32xx family
24	Introduction to Functional Safety
25	Safe Motor Control using TPS65381-Q1
26	Safe Motor Control with TMS570 ARM Cortex-R4F

Start/Stop Function

28	Introduction to Start/Stop
28	Power Management for Start/Stop Function
29	Start/Stop Function Using TI Analog Products
29	TPS40210-Q1 Boost Converter
29	TPIC74100-Q1 Buck-Boost-Converter Integrated Switches
30	TPS40090-Q1 Four-Channel Multiphase Buck DC/DC Controller (or Boost)
30	LM5122 Wide Input Range Synchronous Boost Controller with Multiphase Capability
31	Start/Stop Function Using the C2000™ Piccolo™ MCU

E-Bikes and Small Task-Oriented Vehicles (STOVs)

32	Introduction to E-Bikes and Small Task-Oriented Vehicles (STOVs)
33	STOV Products
33	bq78PL116 Integrated Gas Gauge, Protection and Active Cell Balancing Controller for Up to 16-Series Li-Ion Cells
33	bq76PL102 Dual-Cell Li-Ion Monitor with Active Cell Balancing
34	bq77PL900 Standalone and Host-Controlled Battery Protector for Five- to 10-Series Li-Ion Cells
34	bq77910 and bq77908 Standalone Precision Protector for Four- to 10-Series Li-Ion/ Phosphate Cells
35	bq78412 Pb-Acid Battery State-of-Charge Indicator with Run-Time Display
35	bq77PL157A Stackable Overvoltage Protector for Three- to Six-Series Li-Ion Cells
36	DRV8312-C2-KIT Motor Driver ICs
36	DRV8301 Brushless DC Motor Pre-Driver with Dual-Shunt Amplifiers and a Buck Converter
37	Digital Motor Control for E-Bikes, Scooters and STOVs Evaluation Module
37	C2000™ High-Voltage PFC and Motor Control Developer Kit
38	Microcontroller Product Overview

Isolation and Analog Products

39	Introduction to TI Isolation Products
40	ISO7221X Dual-Channel, 25-Mbps Digital Isolator
41	SN6501 Transformer Driver for Isolated Power Supplies
41	AMC1203 Isolated ADC (1-Bit, 10-MHz, Second-Order, Isolated Delta-Sigma Modulator)
42	Analog Products Overview

System Solutions for Hybrid and Electric Vehicles

Texas Instruments in Automotive Applications

Texas Instruments (TI) is committed to providing superior cost-efficient solutions to the transportation market, along with excellent product documentation, on-time delivery and conformance to specifications.

TI supports transportation industry requirements and continues to add to our transportation portfolio. With more than 30 years of experience serving customers with demanding requirements, TI can help you achieve the quality, reliability and cost goals to succeed in today's marketplace.

TI is fully committed to automotive quality; we have a dedicated quality organization and a zero-defect strategy in place. We are TS16949 certified and a preferred supplier to major car manufacturers.

Introduction to Electric Transportation

Electric transportation is not a new phenomena; in fact, the concept has been around for more than 100 years. However, given growing environmental sensitivities, long-term supply concerns, fossil fuel prices and improved technology, there is a strong motivation to further accelerate this market segment.

Government regulations like the 130-g/km (and future planned 95-g/km) CO2 average emission limits for car manufacturers in Europe are also catalysts behind new electrified transportation alternatives. With the adoption of more electronics, vehicles become safer, exhibit higher

performance, and are more efficient. Electric transportation is a key element within the overall renewable energy landscape. Energy for charging is expected to come from renewable sources like wind-, solar- or water-powered plants. Home and public charging stations will also become more prevalent and can take advantage of off-peak charging (nighttime) and green energy sources such as wind.

With a full range of analog and embedded processing products, TI is at the forefront of helping to bring safer, affordable and more efficient electric transportation solutions to market. TI's solutions for this industry range from

optimized and dedicated integrated circuits to full system-level solutions to help our customers optimize and accelerate product development.

TI's experience in diverse markets such as industrial control, industrial motor drives, digital power supplies, smart metering and grids, wired and wireless communications, consumer electronics, and energy efficiency enables engineers to meet increasing needs for higher speeds, higher precision, lower power and more robust equipment – all while maintaining the high standards of quality and reliability that the automotive and transportation market demands.

Within this guide, you will find solutions and support for your hybrid and electric vehicle application designs in the following categories:

Different types of hybrid and electric vehicles

Feature	Start/Stop	Micro Hybrid	Mild Hybrid	Full Hybrid (Parallel)	Full Hybrid (Serial)	Full Electric
Start/stop alternator	✓	✓	✓	✓		
Regenerative braking		✓	✓	✓	✓	✓
Electric torque assist			✓	✓		
Electric and combustion drive				✓		
Only electric drive possible					✓	✓
Plug-in capability				✓	✓	✓

Different types of hybrid and electric vehicle concepts exist in the market. Texas Instruments offers leading-edge solutions for all systems, from a basic start/stop function to a fully integrated plug-in electric vehicle. This guide will give an overview of the various functions and also cover product highlights from various areas. For the latest information, see TI's website, www.ti.com.

System Solutions for Hybrid and Electric Vehicles

Why TI?

Innovative semiconductor solutions

- Making advanced automotive and transportation devices more flexible, affordable and accessible.
- Addressing growing needs in energy efficiency, power and battery management, wired and wireless connectivity, and performance and precision.

Complete portfolio

- Amplifiers, data converters, interfaces, power management, isolation, logic, DSPs, MCUs and wireless connectivity.
- Catalog, application-specific, enhanced and custom IC options.
- Experienced automotive and transportation sector supplier with a full range of AEC Q-100-certified analog and embedded processing technologies and products.

Quality and reliability

- Experience in serving the automotive market for more than 30 years.
- Ability to serve customers of all sizes with a variety of supplier chains and needs.
- Long product lifetimes and a flexible product obsolescence policy, ensuring continuity of supply.
- Worldwide manufacturing and R&D capabilities.
- Member of industry-standard organizations and alliances.

Commitment

- Design support
- Tools
- Training
- Distribution

Introduction to the guide

This Hybrid and Electric Vehicle Solutions Guide is intended to help you explore TI's IC solutions as the various transportation sectors become increasingly electrified on a path toward energy efficiency and sustainability. This guide features several system block diagrams, followed by details about key devices and support functions.

System Architecture of HEV/EV

The hybrid and electric vehicle system is built of several modules to form the drive train and energy storage system. The battery block (typically a Li-ion chemistry in the range of 400 V) is managed and monitored by the battery management system (BMS) and charged via an on-board AC/DC converter module, with voltages ranging from 110-V single-phase to 380-V three-phase systems. The DC/AC inverter uses the high voltage of the battery to drive the electric motor, but also is used for regenerative braking, storing energy back into the battery.

To connect the high-voltage battery to the conventional 12-V board net requires a DC/DC converter. The connection of a high-voltage battery

to the inverter also requires a reversible DC/DC converter in most cases. The complete HEV system has to meet specific safety requirements (up to ASIL-D) that are specifically relevant for managing the high-voltage battery pack, as well as the drive train used for breaking.

TI is very active in the industrial control segment and can combine extensive application experience with a strong background in the automotive space. Several evaluation modules with hardware and software support will speed up development, while the product roadmap addresses future requirements.

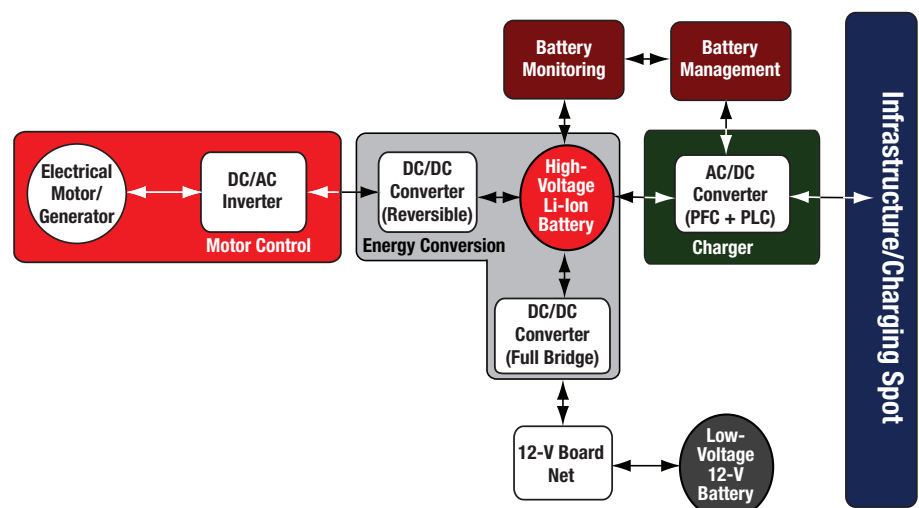

Battery Management

Introduction to Battery Management

Plug-in hybrid electric vehicles (PHEVs) and battery electric vehicles (BEVs) are two quickly emerging technologies that use powerful electric motors as the propulsion source. In order to power these electric motors, large battery packs are made up of hundreds of cells, totaling 300-400 V installed in the vehicle.

Because batteries have a finite energy capacity, PHEVs and BEVs must be recharged on a periodic basis, typically by connecting to the power grid. The charging system for these

vehicles consists of an AC/DC rectifier to generate a DC voltage from the AC line, followed by a DC/DC converter to generate the DC voltage required by the battery pack. Additionally, advanced charging systems might also communicate with the power grid using power line communication (PLC) modems to adjust charging based on power grid conditions. The battery pack must also be carefully monitored during operation and charging in order to maximize energy usage and prolong battery life.

High-performance analog parts are also available to provide critical system functions and features such as sensor feedback, isolation, chip power supplies and communication transceivers.

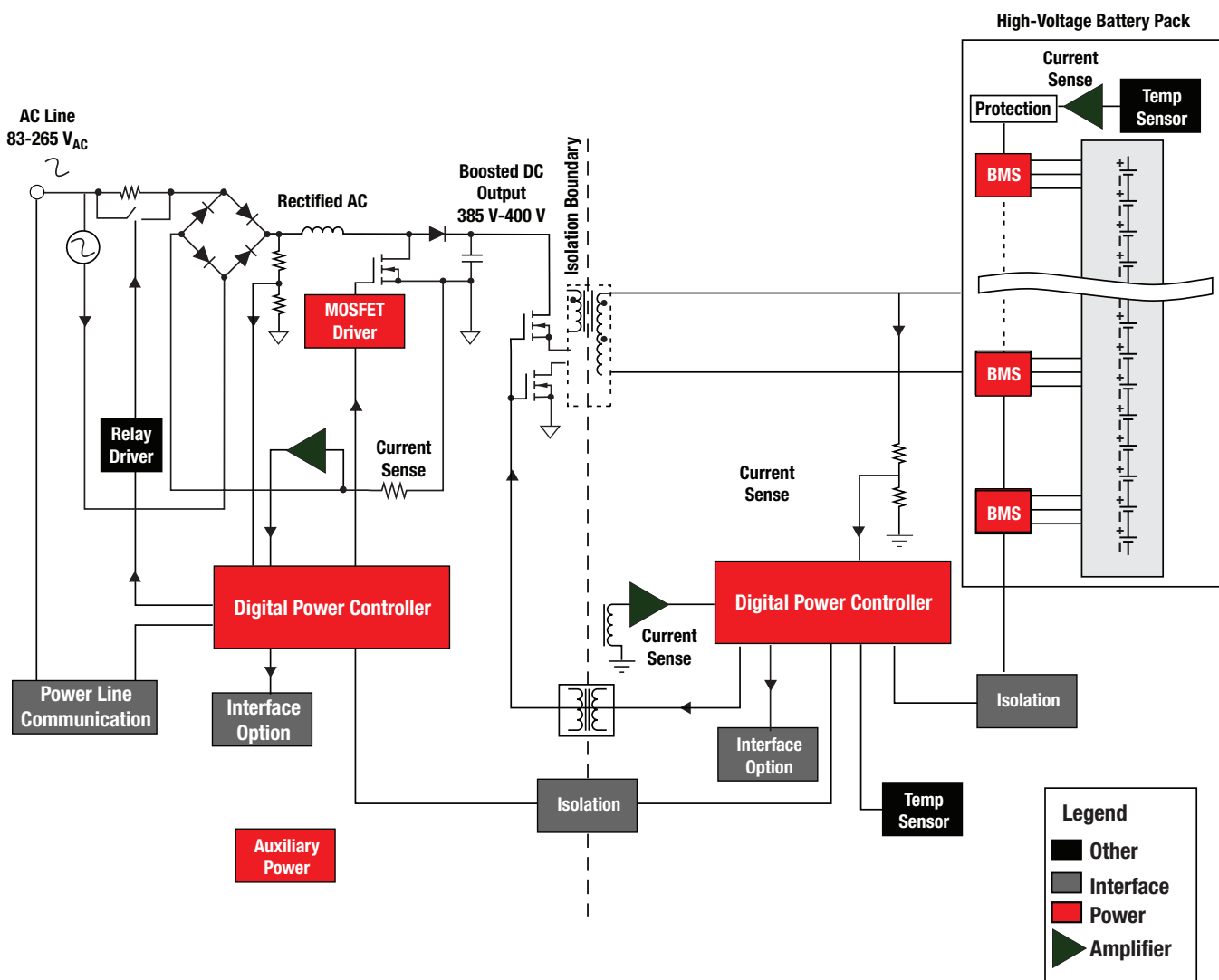

Battery Management

Battery Management Systems

The bq76PL536A family of voltage and temperature monitors and balancers is designed for high-cell-count battery packs. They can handle the voltages and currents found in high-power applications like electronic mobility. The more cells a pack has in a series,

the greater the difference in state of charge, impedance, and capacity affecting the health and energy delivery of the pack. The bq76PL536A device includes circuitry for bringing the cells back into balance. This increases the lifetime of the pack and can help

deliver as much energy to the application as possible. Each bq76PL536A device protects from overcharge, over discharge, and over-temperature for pack and system safety.

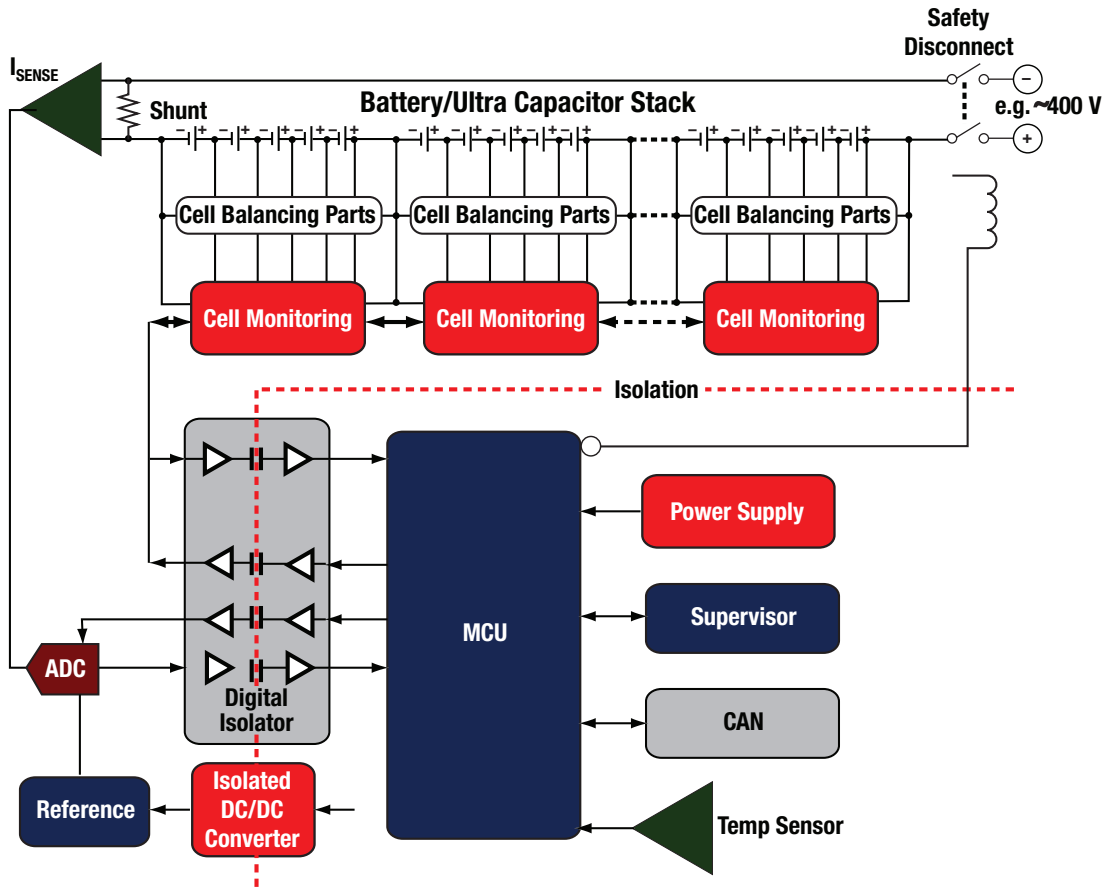

BMS is a key element in the overall HEV architecture. Not only will an intelligent implementation extend the battery's lifetime, but it can also extend the possible range of the vehicle in fully electric drive mode, which is a key selling point to end users.

The battery system is often divided into several submodules that can be placed in various positions in the vehicle. All of these modules require battery supervision and battery cell-balancing features, often connected through different communication paths to ensure system

redundancy. Built-in temperature management is also a crucial element for the system lifetime, and for safety. The complete battery system represents a highly safety-critical function; therefore, the microcontroller needs to meet specific safety requirements.

Battery Management

Battery Management: Applications

bq76PL536A-Q1 Stackable Monitor, Protector and Balancer for Three- to Six-Series Li-Ion Cells

The bq76PL536A is a stackable, three- to six-series cell lithium-ion battery pack protector and analog front end (AFE) that incorporates a precision analog-to-digital converter (ADC), independent cell voltage and temperature protection, cell balancing, and a precision 5-V low dropout regulator (LDO) to power user circuitry. The bq76PL536A provides full protection (secondary protection) for overvoltage, undervoltage and overtemperature conditions. When safety thresholds are exceeded, the bq76PL536A sets the fault output. No external components are needed to configure or enable the protection features.

Cell voltage and temperature protection functions are independent of the ADC. The bq76PL536A is intended to be used with a host controller to maximize the functionality of the battery management system. However, the protection functions do not require a host controller. The bq76PL536A can be stacked vertically to monitor as many as 192 cells without additional isolation components between ICs.

Key Features

- Three- to six-series cell support, all chemistries hot-pluggable
- Stackable vertical SPI interface
- No isolation components required
- High-speed SPI for data communications
- Dedicated fault signals
- High-accuracy ADC:
 - ± 1 -mV typical, ± 3 -mV max
 - 14-bit resolution
 - 6- μ s conversion time
- Nine ADC inputs: six cell voltages, one six-cell “brick,” voltage, two temperatures, one general-purpose input
- Built-in comparators (secondary protector) for overvoltage, undervoltage and over-temperature protection
- Programmable thresholds and delay times
- Supply voltage range from 5.5 V to 30 V
- Low power:
 - 12- μ A sleep current typical
 - 48- μ A idle current typical
- Integrated precision 5.0-V 3-mA LDO

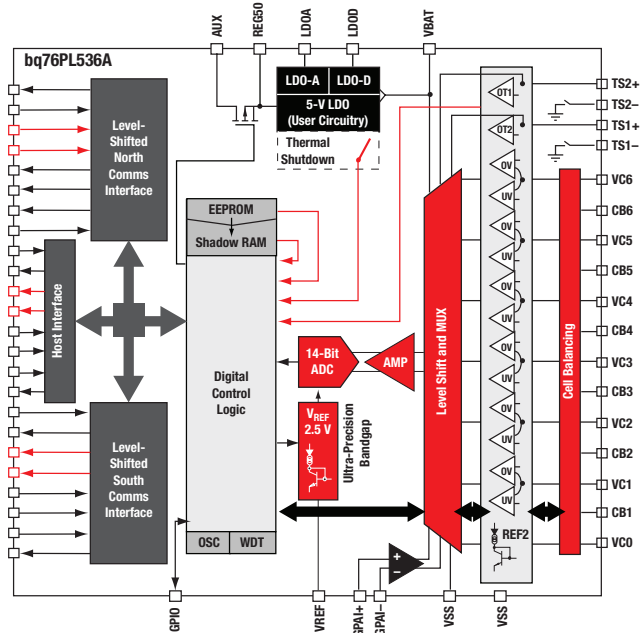

Learn more at: www.ti.com/sc/device/bq76PL536A-Q1

bq76PL536A Evaluation Module

- Can handle up to 18 cells, three PL536 on the board
- Works with battery cells or power supply input
- Includes 2.5-kV galvanic isolation for host CPU or PC
- Software interface for easy system evaluation
- Order part number: bq76PL536AEVM
- MSP430EVM + bq76PL536AEVM App Note includes basic battery management code

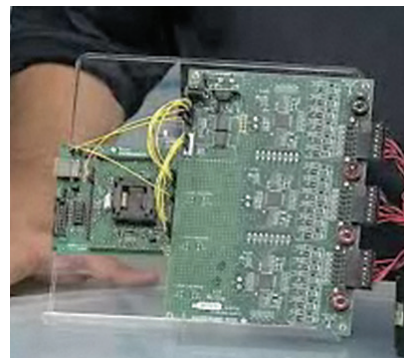

Learn more at: www.ti.com/sc/device/bq76PL536A

MSP430EVM + bq76PL536AEVM (see application note)

Power Conversion Systems

Introduction to Power Conversion

The DC/DC converter module is used to connect the high-voltage battery to the 12-V vehicle power net. The system can either be realized with fixed PWM

controllers or an MCU controlling both the high- and low-voltage side of the converter. This method offers more flexibility using a common hardware

platform, with adjustments done in the software only and additional capabilities like diagnostic features.

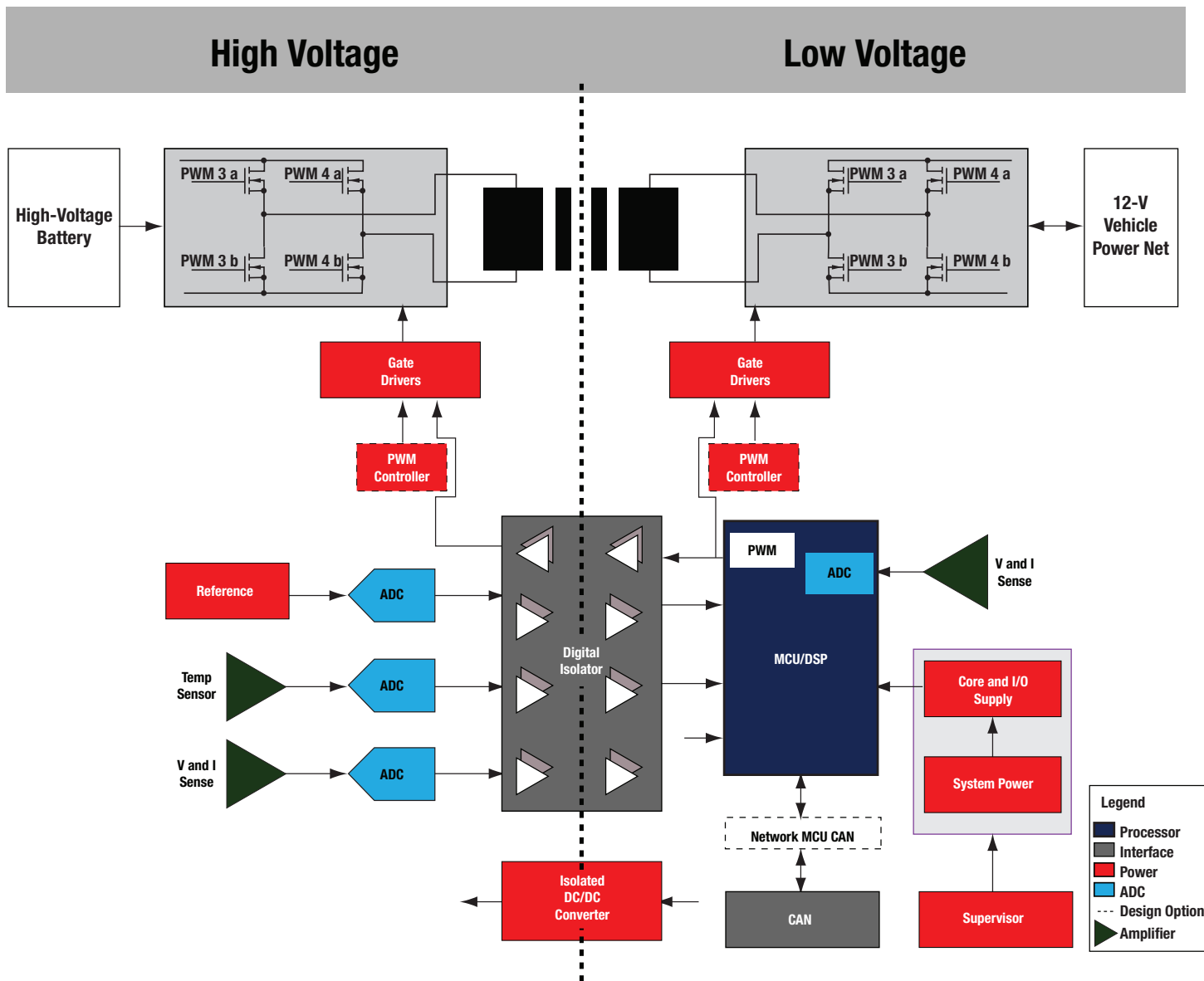

Power Conversion Systems

DC/DC Converter Using UCC28950-Q1

UCC28950-Q1 Green Phase-Shifted Full-Bridge Controller with Synchronous Rectification

The UCC28950-Q1 enhanced phase-shifted controller builds upon Texas Instruments' industry-standard UCCx895 phase-shifted controller family with enhancements that offer best-in-class efficiency in today's high-performance power systems. The UCC28950-Q1 implements advanced control of the full bridge along with active control of the synchronous-rectifier output stage.

The primary-side signals allow programmable delays to ensure ZVS operation over wide load-current and input-voltage ranges, while the load current naturally tunes the secondary-side switching delays of the synchronous rectifiers, maximizing overall system efficiency.

Key Features

- Qualified for automotive applications
- AEC-Q100 qualified with the following results:
 - Device temperature grade 1: -40°C to 125°C ambient operating temperature range
 - Device HBM ESD classification level H2
 - Device CDM ESD classification level C3B
- Enhanced wide-range resonant zero-voltage switching (ZVS) capability
- Direct synchronous rectifier (SR) control
- Light-load efficiency management
- Average- or peak-current mode control with programmable slope compensation and voltage-mode control
- Closed-loop soft-start and enable function
- Programmable switching frequency up to 1 MHz with bidirectional synchronization
- ($\pm 3\%$) Cycle-by-cycle current limit protection with hiccup mode support
- 150- μA start-up current
- V_{DD} undervoltage lockout

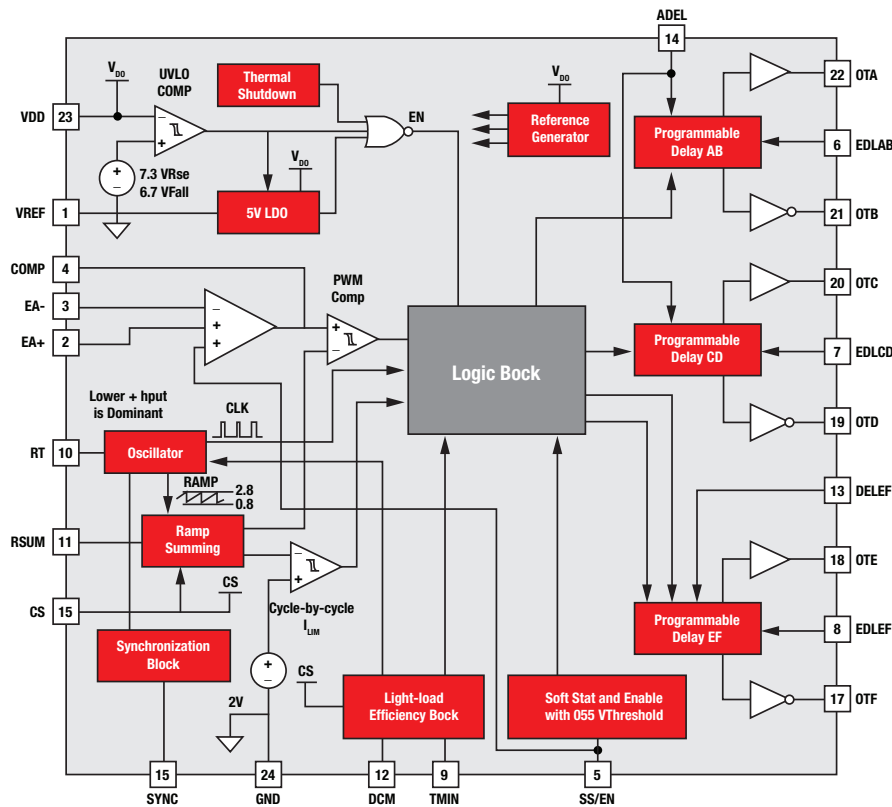

Learn more at: www.ti.com/sc/device/UCC28950-Q1

Power Conversion Systems

DC/DC Converter Using C2000™ Piccolo™ MCUs

In automotive solutions, a bidirectional DC/DC converter is useful in many applications. For example, on the high-voltage side, an H-bridge topology is used to drive an inverter for the electric motor. When the driver steps on the brake, an H-bridge on the secondary side can use the back electromotoric force (EMF) to recharge the battery. Alternatively, a bidirectional DC/DC converter can be used in systems that have both a high-voltage lithium-ion battery and an automotive 12-V battery to add more capabilities, as well as increase flexibility.

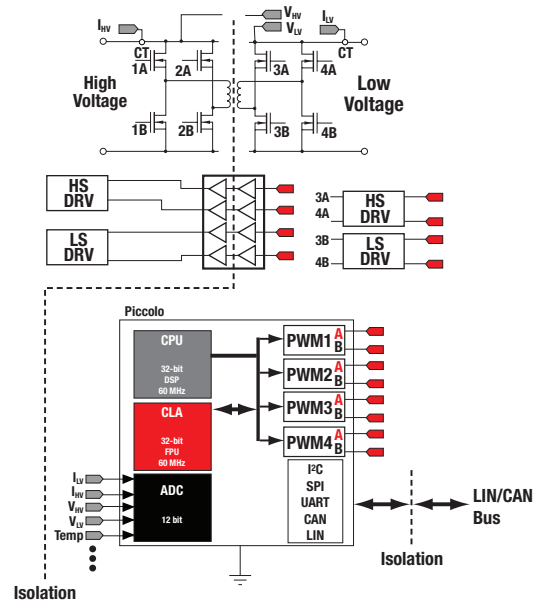

C2000™ Piccolo™ F2802x Family

TMS320F2802x devices feature architectural advancements and enhanced peripherals in packages from 38 pins to bring the benefits of 32-bit real-time control to applications typically unable to justify the associated cost. Real-time control offers greater system efficiency and precision through the implementation of advanced algorithms. For more information, see a full C2000 Piccolo part list on page 34, or visit www.ti.com/c2000.

Key Features

- Qualified for automotive applications
- C28x™ MCU 32-bit CPU
- Single-cycle 32-bit MAC
- Up to 60-MHz performance
- Full software compatibility with previous generations

Memory

- Flash: 16, 32, 64 KB
- RAM: 4, 6, 10, 12 KB

Peripheral highlights

- Single 3.3-V supply
- Two high-accuracy on-chip oscillators (10 MHz)
- Best-in-class PWM and event capture
- 150-ps resolution on PWM duty and frequency
- 12-bit ratio-metric ADC with individual channel triggers and 4.6-MSPS speed
- Two analog comparators with 10-bit reference
- Robust serial communication interfaces
- Up to 22 general-purpose I/Os
- Packages: 38-pin TSSOP, 48-pin LQFP

PWMs: Includes ePWM channels and captures used as basic PWMs.

Timers: Timers include CPU, PWM and watchdog timers.

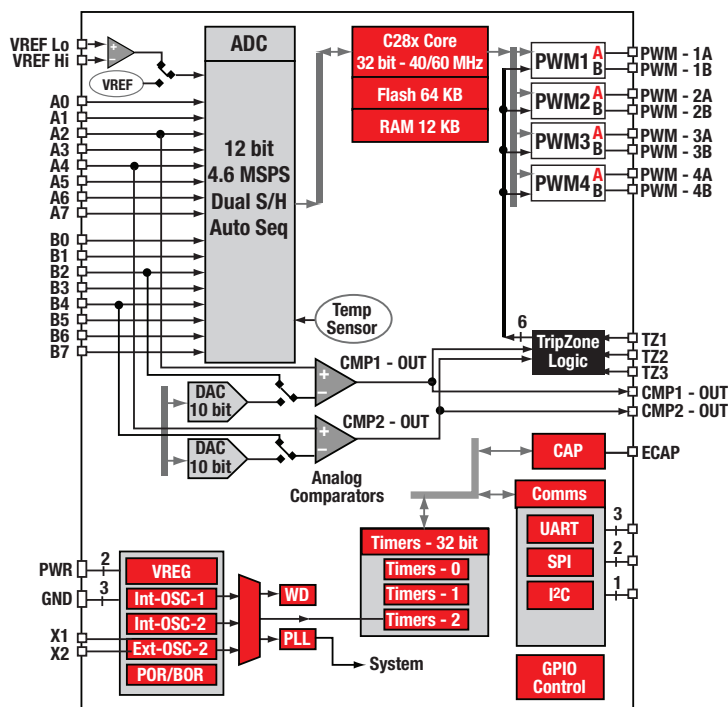

Power Conversion Systems

DC/DC Converter Using C2000™ Piccolo™ MCUs

C2000™ Digital Power DC/DC Developer Kits

Digital power experimenter's kit (\$229) offers:

- Two-rail DC/DC EVM using TI PowerTrain™ modules (10 A), F2808 controlCARD™ controller subsystem
- On-board digital multimeter and active load for transient response tuning

Order part number: TMDSDCDC2KIT

DC/DC developer's kit (\$325) offers:

- Eight-rail DC/DC EVM using TI PowerTrain modules (10 A)
- Application software with example code and full hardware details
- Demonstrates multirail and multiphase applications
- Includes F28044 controlCARD controller subsystem

Order part number: TMDSDCDC8KIT

Resonant DC/DC developer's kit (\$229) offers:

- Single transformer LLC resonant DC/DC converter
- Four different feedback methods for experimentation
- Lossless current sensing circuit for fault protection
- Active load for transient response tuning
- Includes F2808 controlCARD controller subsystem

Order part number: TMDSRESDCKIT

Phase-shifted full-bridge developer's kit (\$550) offers:

- 300- to 400-V DC input / 12-V output, up to 600 W
- Synchronous rectification
- Efficiency: 95 percent at peak
 - 90 percent at 10 percent to 90 percent of rated power
- Output transient response:
 - $< \pm 3$ percent, < 0.2 mS, on 10 to 80 percent load change at 1.0 A/ μ s
- Control methods:
 - Peak current-mode control with on-chip slope compensation (no external circuitry)
 - Optimized sync, rectification control
 - Voltage-mode control

Order part number: TMDSHVPSFBKIT

LLC resonant developer's kit (\$400) offers:

- 300- to 400-V DC input 12-V DC output, up to 300 W
- Half-bridge with synchronous rectification
- Efficiency: 93.6 percent peak, 85 percent at 10 percent load
- Output transient response:
 - $< \pm 3$ percent, < 0.2 mS, on 10 to 80 percent load change at 1.0 A/ μ s
- Control methods:
 - Soft start
 - Resonant mode control
 - Adaptive ZVS
- Optimized synchronous rectification control
- Protection: overcurrent, overvoltage, undervoltage

Order part number: TMDSHVRESLLCKIT

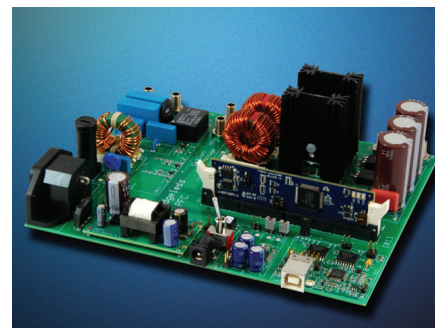
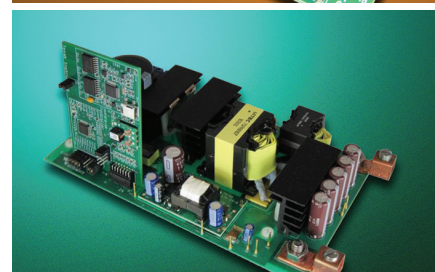
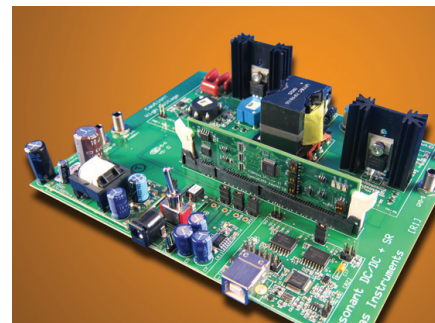
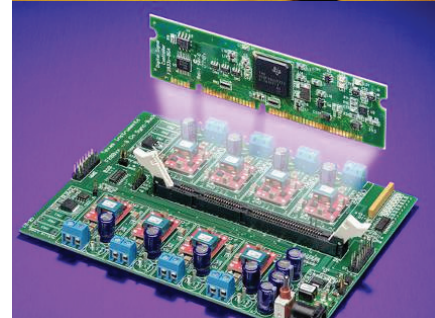
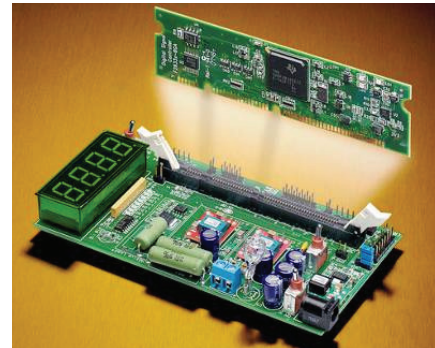

Charging and Charging Infrastructure

Introduction to Charging and Charging Infrastructure

The charging infrastructure connects the car to the smart power grid. The cost for the individual charging spot has to be balanced with the additional expansion capabilities on the communication side. The obvious choice for communication is a wired system via the charging cable, where power line communication is a widely used method. In that area, several activities for standardization are ongoing at the utilities side.

Texas Instruments is actively involved in standards development and offers solutions for SFSK and narrowband OFDM systems for the CENELEC A and B band, with OFDM standards like PRIME/G3.

The TMS320F28x microcontroller family is a flexible platform meeting these standards, with reference designs available.

Other options like RF communication using ZigBee or ISM band solutions are available, as are RFID systems for customer identification and prepayment options at the charging spot. The metering function for single-phase up to complex three-phase solutions can be realized with single-chip solutions out of the MSP430™ MCU family.

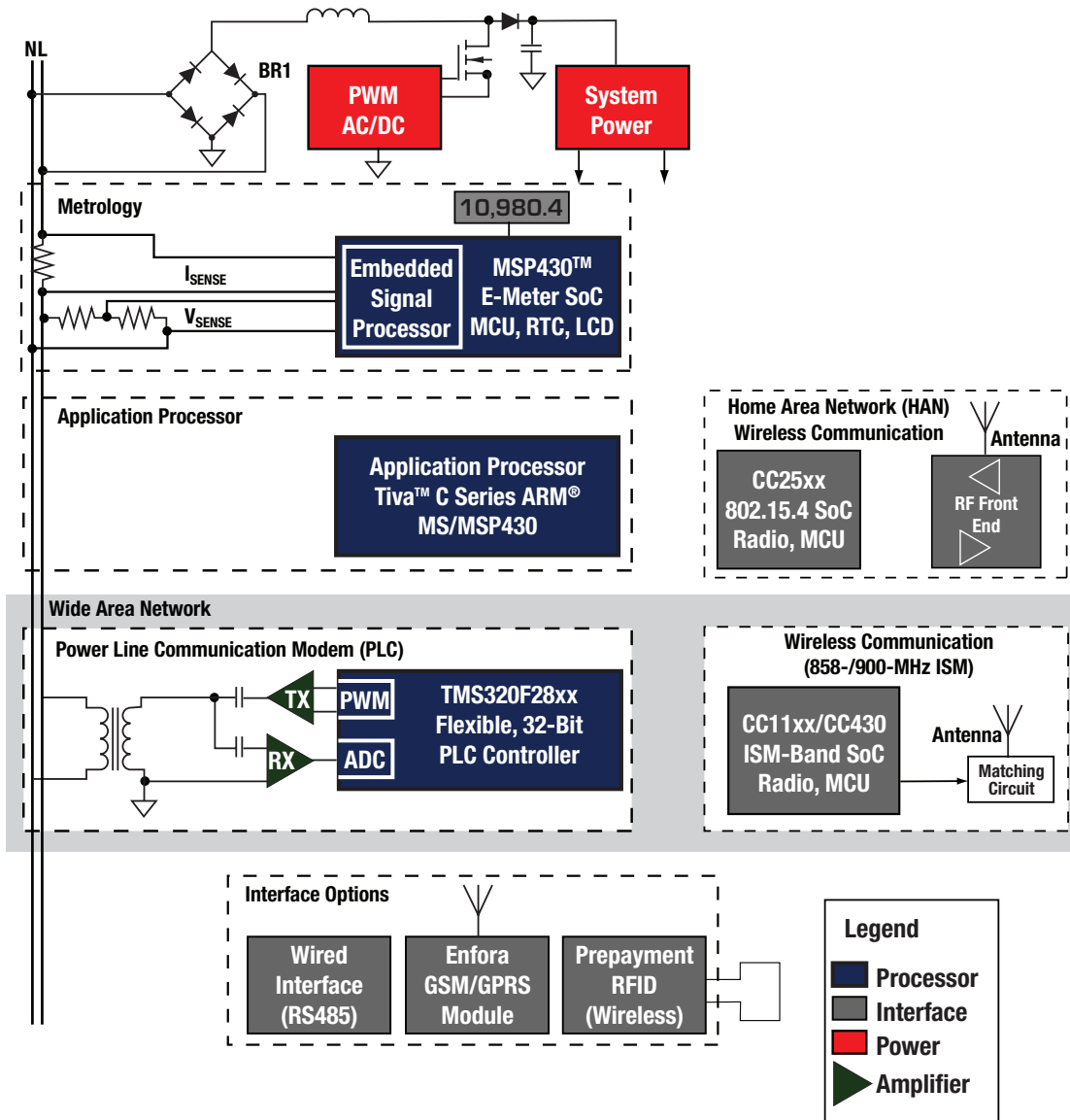

For more information, see www.ti.com/metering

Charging and Charging Infrastructure

AFE031 Integrated PLC Analog Front End

PLC Developer Kit

The new AFE031 integrates all PLC analog front end functionality into a single chip. Discrete implementation today ~100 parts. Sampling 2Q11.

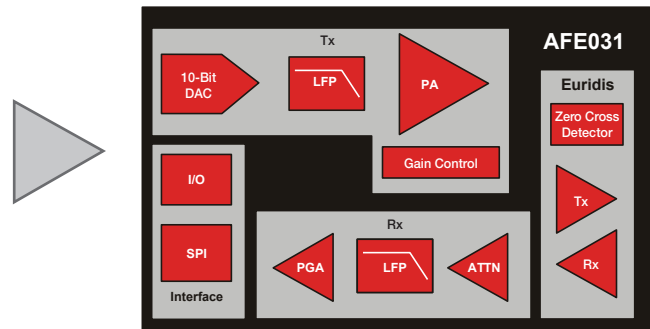
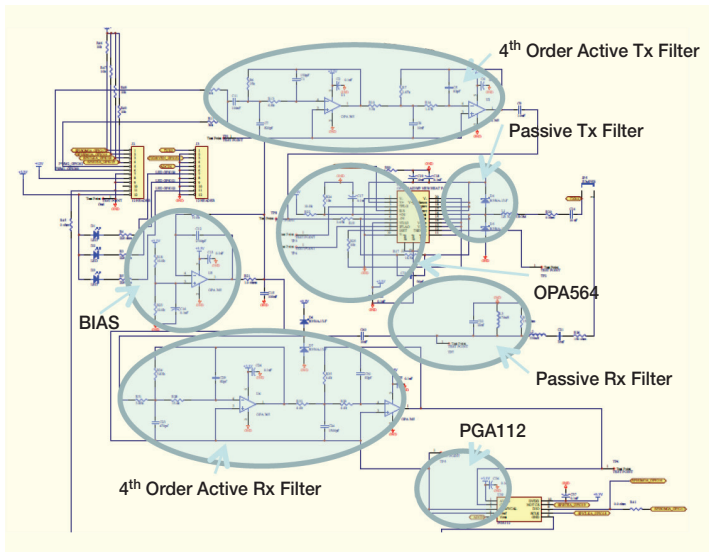

Learn more at: www.ti.com/sc/device/AFE031

TI PLC Modem Development Kit (TI PLC DK)

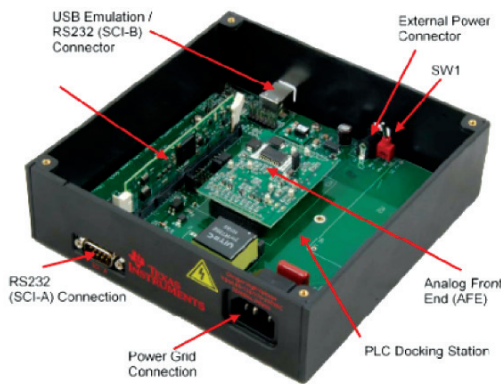

The TI PLC DK contains:

- Two PLC modems
- Power supply and cables
- GUI and documentations
- Run any IP applications through PC host
- Order part number: TMDSPCKIT-V2
- Price: \$599 US
- Distribution and TI eStore
- plcSUITE software available via download

- Robust narrowband PLC modem over low-/medium-voltage power line
- PLC standards/modulation supported
 - PRIME
 - G3
 - FlexOFDM
 - IEC61334 S-FSK
- Scalable data rates up to 128 Kbps for single phase
- Software reference design package: plcSUITE APIs, libraries, source codes
- AFE operating frequency range 9-500 kHz (different filters)
- Easy integration into endpoint or network devices of AMR/AMI systems
- NRE- and royalty-free

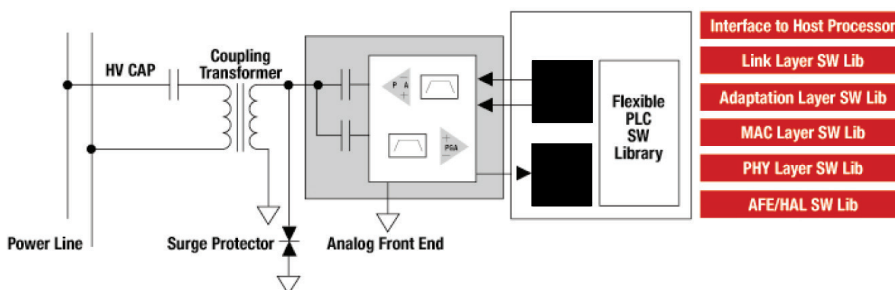

Learn more at: www.ti.com/pic

Charging and Charging Infrastructure

Charger Systems – AC Levels 1 and 2 (Onboard)

Since batteries have a finite energy capacity, PHEVs and BEVs must be recharged on a periodic basis, typically by connecting to the power grid in some form. For most users, Level 1 charging (120 VAC at 15 A-20 A) will be the most available power supply that all onboard chargers should be capable of handling, as it will be easily accessible to all users. In its current state, most users would prefer to take advantage of the faster charging Level 2 (240 VAC at 40 A) that will allow for faster charging times compared to the

Level 1, but will require a larger power source to supply the appropriate current and voltage. By having the capacity to handle both types of charging, you provide users with more flexibility in their charging options and a larger number of locations where a charge can be delivered.

The Level 1 and 2 charging system for these vehicles consists of an AC/DC converter to generate a DC voltage from the AC line. This incoming power needs to undergo power factor correction (PFC) to boost the power factor to meet regional regulatory standards.

At the heart of the inverter is a real-time C2000™ microcontroller. This controller is programmed to perform the control loops for all necessary power management functions, including AC/DC with PFC and DC/DC to create the necessary charge profile for the battery. The C2000 controller contains advanced peripherals such as high-precision PWM outputs and ADCs, and is designed to read the ADC and adjust the PWM within a single clock cycle, making real-time control possible.

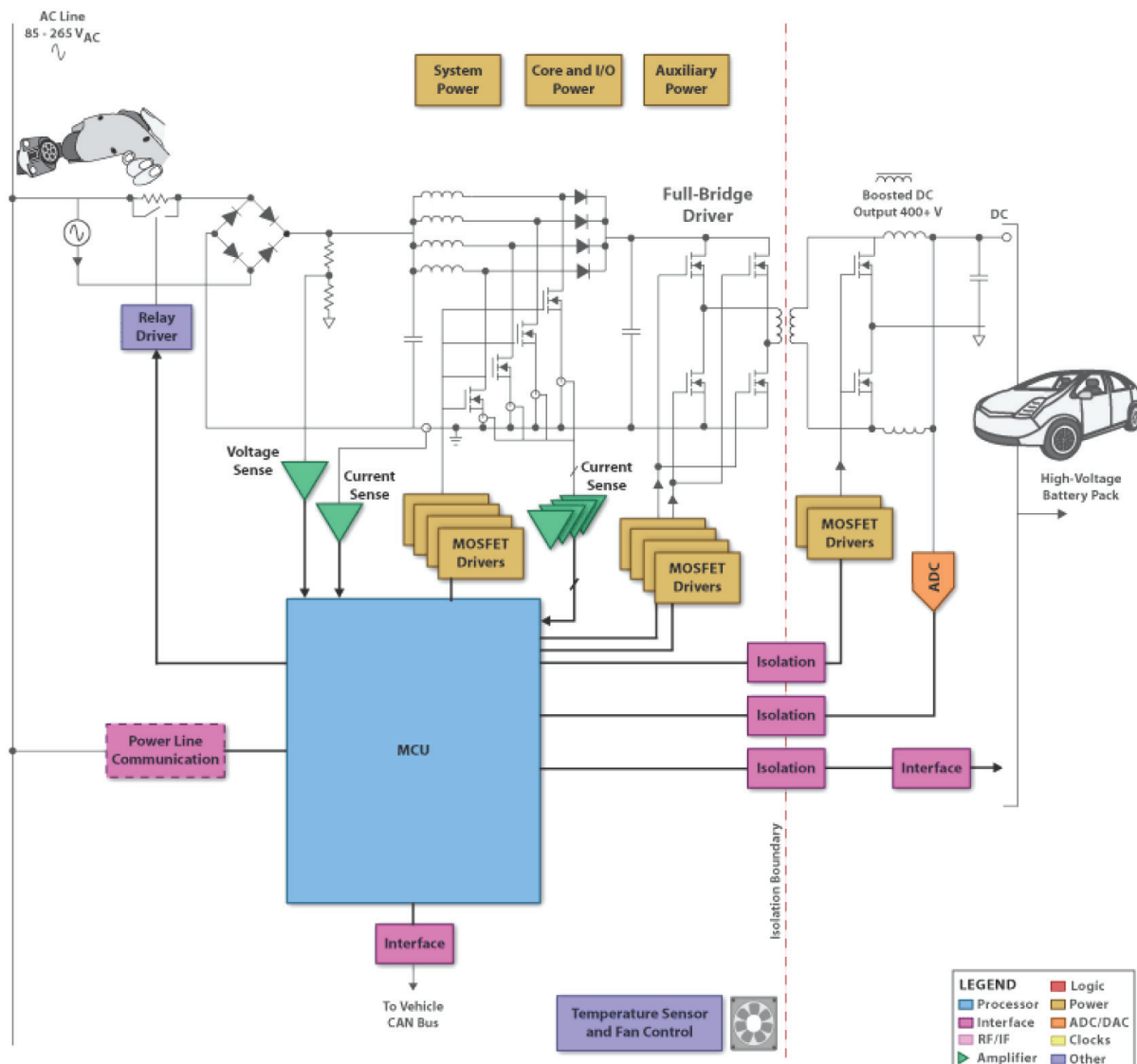

Charging and Charging Infrastructure

Charger Systems – DC Level 3 (Offboard)

Level 3 charging will play a key role in the public charging area in order to reduce charging time and make it more feasible for users to benefit from on-the-go charging.

The Level 3 charging system for these vehicles consists of an AC/DC converter to generate a DC voltage from the AC line. This incoming power needs to undergo power factor correction (PFC) to meet regional regulatory standards. At the heart of the inverter is a real-time C2000™ microcontroller. This controller is programmed to perform the control loops for all necessary power management functions, including AC/

DC with PFC and DC/DC to create the necessary charge profile for the battery. The C2000 controller contains advanced peripherals such as high-precision PWM outputs and ADCs, and is designed to read the ADC and adjust the PWM within a single clock cycle, making real-time control possible.

Communications on a simple system can be handled by a single processor. More elaborate systems with complex displays and online billing/reporting, such as Level 3 charging, may require a secondary controller. Implementing a low-frequency narrow-band PLC (LF

NB PLC) solution provides an optimal fit in terms of bandwidth, power and cost requirements. Operating in the narrowband domain (frequencies up to 500 kHz) ensures data integrity while minimizing system cost. In doing so, this standard would leverage the existing power line infrastructure and provide a cost-effective means of integrating intelligent monitoring and control into new automotive systems. Data rates can vary from 1.2 Kbps up to hundreds of Kbps based on the existing standards.

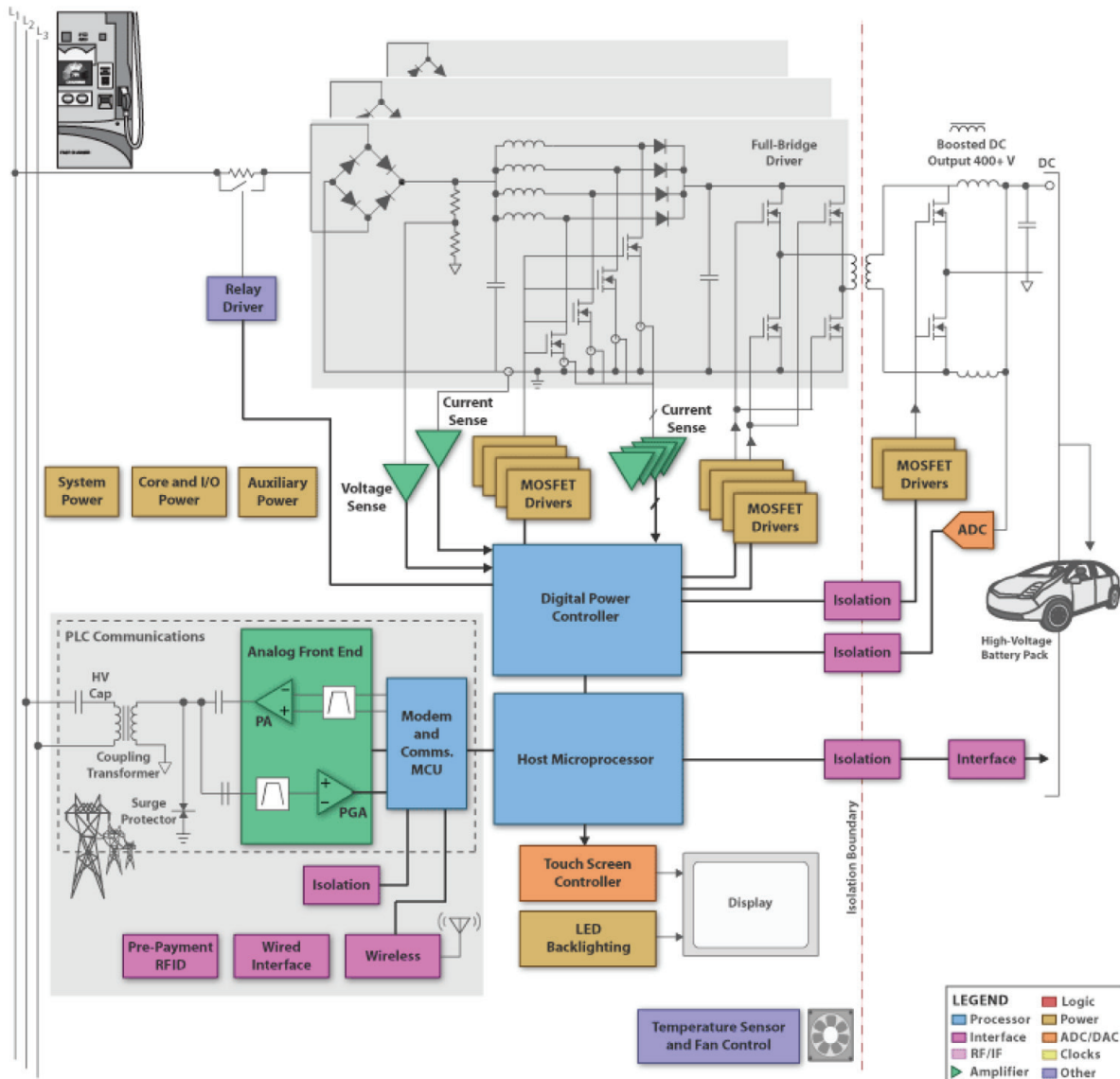

Charging and Charging Infrastructure

AC/DC Converter with PFC Using C2000™ Piccolo™ MCUs

The charging of the HEV/EV via the main grid demands a flexible setup to meet the various voltage levels in single-phase (120 V, 230 V) and three-phase 380-V systems with different current levels (16 A to 63 A). The charging time is certainly an important feature for the car's end customer, but

has to be balanced with the long-term aging behavior of the battery pack.

The AC/DC charging system shown offers a power factor control (PFC) function along with high-voltage power conversion to directly generate the battery's DC charging voltage. An

optional power line communication (PLC) to communicate with the charging infrastructure can be implemented as well. This setup demands a high number of pulse-width modulation and analog-to-digital converter channels, along with powerful CPU performance.

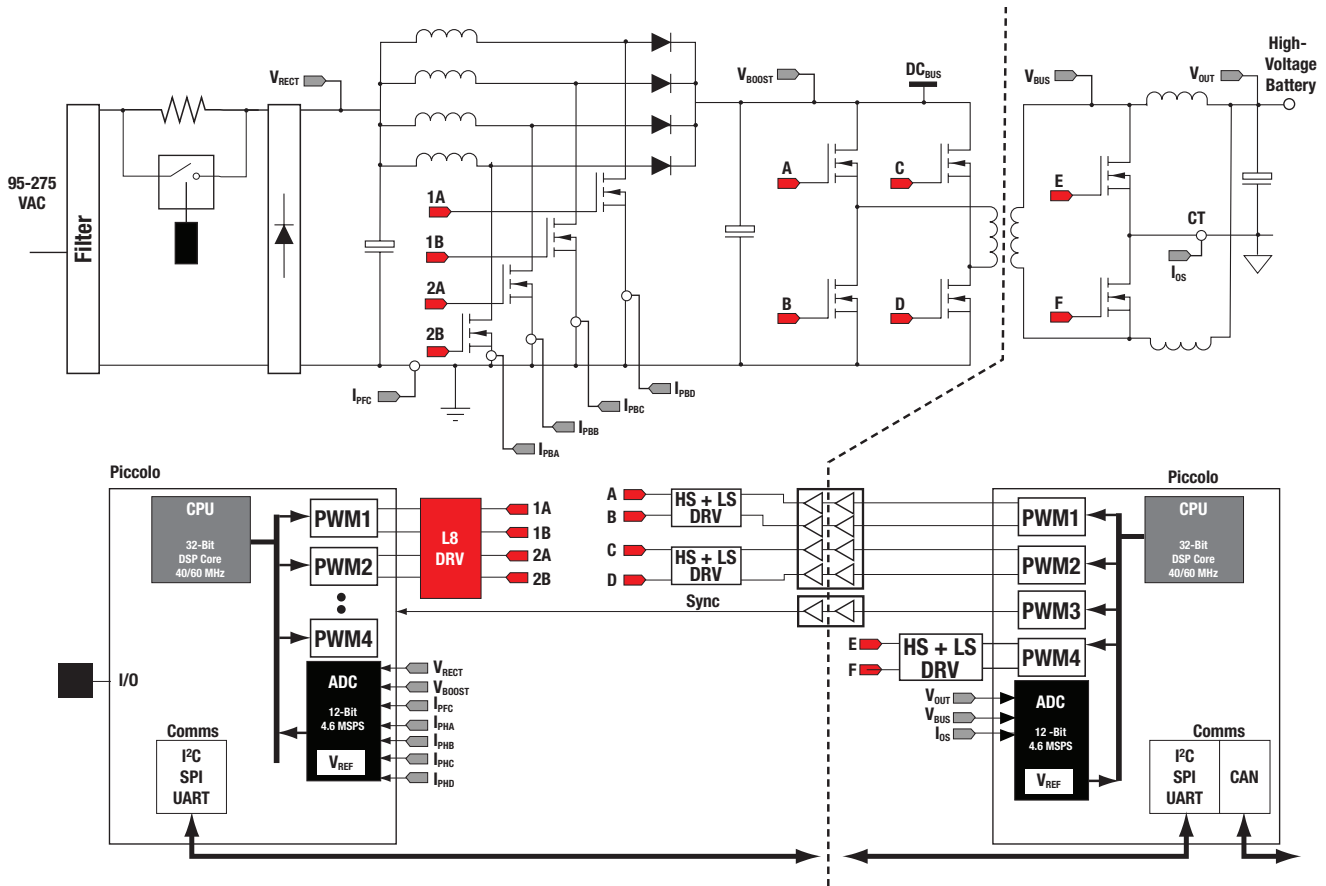

AC/DC Development Kits with C2000™ MCUs

- Complete, low-power rectifier development platform for prototyping communications systems
- AC/DC EVM with interleaved PFC and phase-shifted full bridge
- Primary side control, synchronous rectification, peak current-mode control, two-phase PFC with current balancing
- Contains an 80-W (max) system that uses a two-phase interleaved PFC front end and a phase-shifted full-bridge rectifier stage
- Includes F2808 controlCARD™ controller subsystem
- Available for \$695

Order part number: TMSACDCKIT

Learn more at: www.ti.com/c2000tools

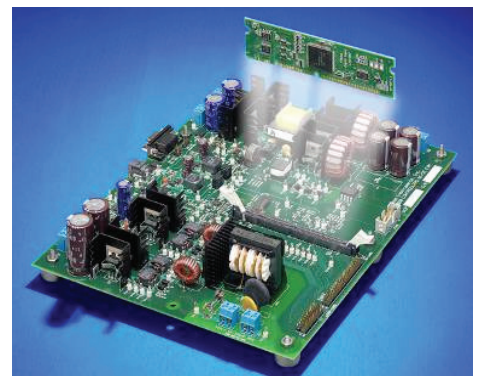

Charging and Charging Infrastructure

AC/DC Converter with PFC Using C2000™ Piccolo™ MCUs

AC/DC Development Kits with C2000™ MCUs

Power factor correction developer's kit (\$550) offers:

- Two-phase interleaved power factor correction
- 90-260 VAC input, 300-W output up to 390 V
- Full load efficiency >90 percent
- Power factor correction at 50 percent or greater load – 0.9 min
- Supports multiple control topologies

Order part number: TMDSHVPFCKIT

Bridgeless PFC developer's kit (\$450) offers:

- Higher efficiency – no bridge losses
- 90-260 VAC input, 300-W output up to 400 V
- Power factor correction at 50 percent or greater load – 0.9 min
- Supports multiple control topologies
- Half-cycle (AC) RMS feed-forward loop
- Faster DC bus voltage response without sacrificing PF
- RMS input VF monitoring
- Onboard EMI filter
- Protection: overcurrent, overvoltage, undervoltage

Order part number: TMDSHVBLPFCKIT

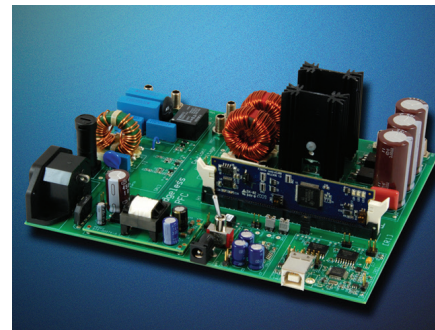
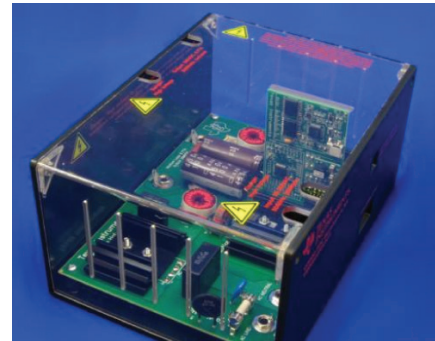

Why Piccolo™ MCUs?

The Piccolo™ F2802x/F2803x family of C2000™ MCUs provides a low-cost, high-integration solution to help drive processor-intensive real-time control into cost-sensitive applications. With a host of industry-leading

integrated modules, such as a powerful ADC, dedicated high-resolution PWMs and the unique control law accelerator (CLA), Piccolo MCUs are ideal for power conversion in electric vehicles. For more complex systems, like those with integrated power line

communication, several additional members of the C2000 family are available, offering floating-point performance up to 300 MHz and high-performance peripherals like a 12.5-MSPS 12-bit ADC.

Benefit	Enabling Feature
Improved system efficiency/accuracy	<ul style="list-style-type: none"> • High-performance C28x™ core supports adaptive control algorithms for efficiency across load curve • High-resolution 150-ps PWM modules and high-speed on-chip ADC
Added functions/features	<ul style="list-style-type: none"> • Communication with outside systems: CAN, LIN, I²C, UART, SPI • Multiple PWMs allow multiple DC output rails
Better R&D efficiency	<ul style="list-style-type: none"> • Software control adaptable to multiple topologies and power ratings
Increased reliability	<ul style="list-style-type: none"> • Digital control can adapt to environmental conditions and be recalibrated in software • Software can implement failure prediction

Take a look on page 34 for a full configuration table of Piccolo MCUs for hybrid and electric vehicles.

Learn more at: www.ti.com/c2000

Charging and Charging Infrastructure

AC/DC Converter with PFC Using C2000™ Piccolo™ MCUs

Piccolo™ MCUs F2802x vs. F2803x

The TMS320F2803x includes the same C28x™ MCU core, enhanced high-resolution PWM technology and a high-speed ADC, but combines more features and additional memory.

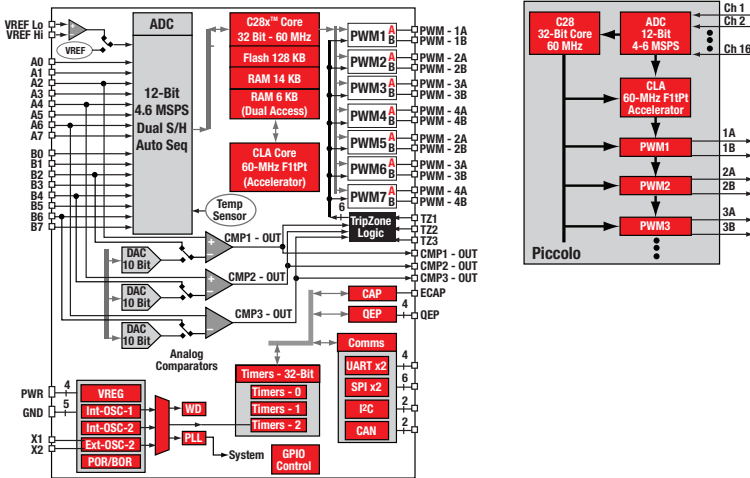

Key Features

- Up to 128-KB flash, 20-KB RAM
- All-new CLA: independent, floating-point processing unit with direct access to ADC and PWMs enables parallel control loop execution
- Additional three ePWM modules (six PWM outputs)
- Quadrature encoder interface (eQEP)
- Three on-chip comparators
- Added communication ports – CAN 2.0B with up to 16 mailboxes, LIN/UART and additional SPI
- Packages: 64-pin TQFP, 80-pin LQFP

Learn more at: www.ti.com/piccolo

ControlSuite™ Software

ControlSuite™ software for C2000™ microcontrollers is a cohesive set of infrastructure and software tools designed to minimize software development time. From device-specific drivers and support software to complete system examples in sophisticated system applications, ControlSuite software provides libraries and examples at every stage of development and evaluation. ControlSuite software contains a full digital motor control library as well as motor control kits.

One stop for all C2000 MCU software:

- Single, centralized location
- Intelligent installer eliminates the search for dependencies

Open, real-world systems:

- Compilation of 15 years of systems and applications expertise
- Unique, optimized libraries for math, filtering, DSP and specific applications, with complete system examples utilizing incremental builds
- Allows developers to focus on differentiation, not basics

Program the MCU your way:

- Significantly reduce development time with hardware abstraction and extensive libraries
- Four interusable levels of hardware abstraction

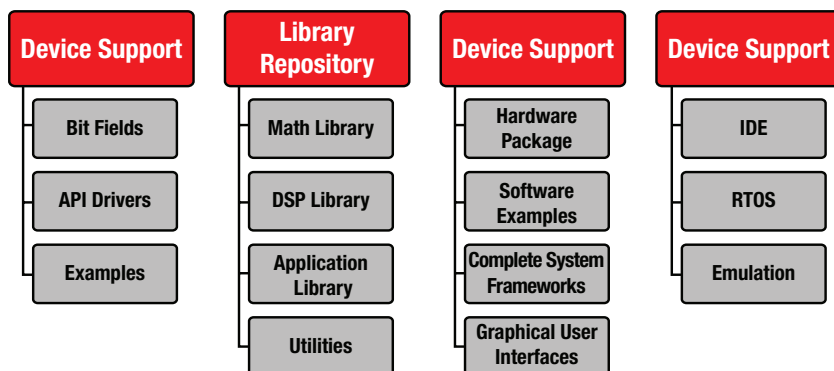

ControlSuite Software Support for Motor Control

Motor	Technique	Type	Feedback
ACI	FOC	Speed and Torque	Tachometer
	FOC	Speed and Torque	Sensorless
BLDC	Trapezoidal	Speed	Half Effect
	Trapezoidal	Speed	Sensorless
	Sinusoidal	Speed	Half Effect
	Sinusoidal	Speed	Sensorless
PMSM	FOC	Speed and Torque	Encoder
	FOC	Position	Encoder
	FOC	Speed and Torque	Sensorless
Stepper	Microstep	Position	Sensorless
Brushed	DirectDrive	Speed and Position	Encoder

Learn more at: www.ti.com/controlsuite

Charging and Charging Infrastructure

Power Factor Correction with UCC

UCC28070-Q1 Two-Phase Interleaved Constant-Current-Mode (CCM) Power Factor

The UCC28070-Q1 is an advanced PFC device that integrates two pulse-width modulators (PWMs) operating 180 degrees out of phase. This interleaved PWM operation generates substantial reduction in the input and output ripple currents, and the conducted EMI filtering becomes easier and less expensive. A significantly improved multiplier design provides a shared current reference to two independent current amplifiers, ensuring matched average current-mode control in both PWM outputs while maintaining a stable, low-distortion sinusoidal input line current.

The UCC28070-Q1 contains multiple innovations, including current synthesis and quantized voltage feed-forward correction to promote performance enhancements in PF, efficiency, THD and transient response. Features including frequency dithering, clock synchronization and slew-rate enhancement further expand the potential performance.

The UCC28070-Q1 also contains a variety of protection features, including output overvoltage detection, programmable peak-current limit, undervoltage lockout and open-loop protection.

Key Features

- Interleaved average current-mode PWM control with inherent current matching
- Advanced current synthesizer current sensing for superior efficiency
- Highly linear multiplier output with internal quantized voltage feed-forward correction for near-unity PF
- Programmable frequency (10 kHz to 300 kHz)
- Programmable maximum duty-cycle clamp
- Programmable frequency dithering rate and magnitude for enhanced EMI reduction
- Magnitude: 3 kHz to 30 kHz
- Rate: up to 30 kHz
- External clock synchronization capability
- Enhanced load and line transient response through voltage amplifier output slew-rate correction
- Programmable peak-current limiting
- Bias-supply UVLO, overvoltage protection, open-loop detection and PFC-enable monitoring
- External PFC-disable interface
- Open-circuit protection on VSENSE and VINAC pins
- Programmable soft start
- 20-lead TSSOP/SOIC package

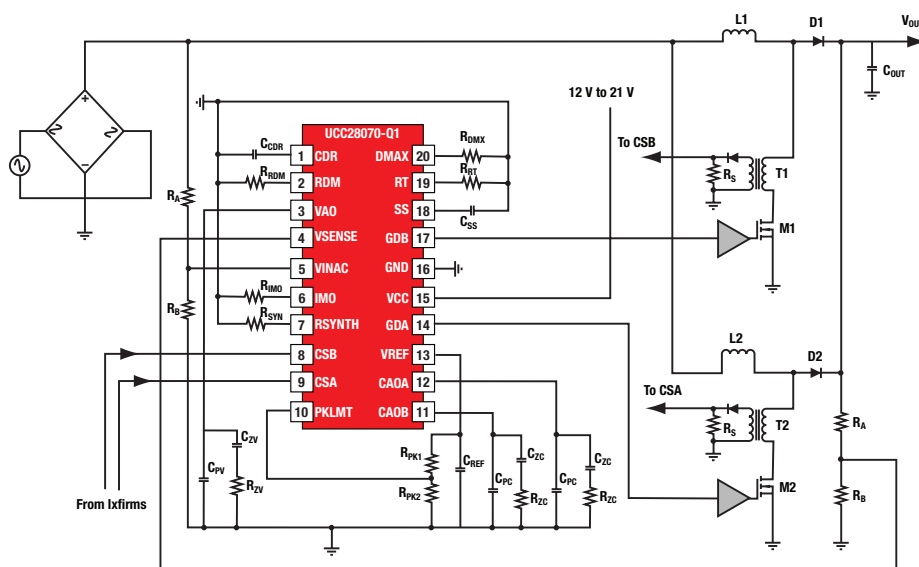

Learn more at: www.ti.com/piccolo

Motor Control

Introduction to Motor Control and Drive

The inverter will drive the electric motor for fully electric operation in full hybrids and EVs as well as for torque assist in a mild hybrid car concept. This can be done with a single motor positioned to drive one axis, but also using in-wheel motors to individually drive each

wheel of the car. The microcontroller used may be required to meet strict safety requirements/standards, as not only the driving but also recuperative braking is controlled through this unit. In addition, the PWM's output signals and sensing inputs have to be

controlled, still embedded in the overall safety concept. Like with any other element in the HEV/EV space, isolation is especially important in the inverter module. Learn more about motor drive and control solutions from Texas Instruments at www.ti.com/motor.

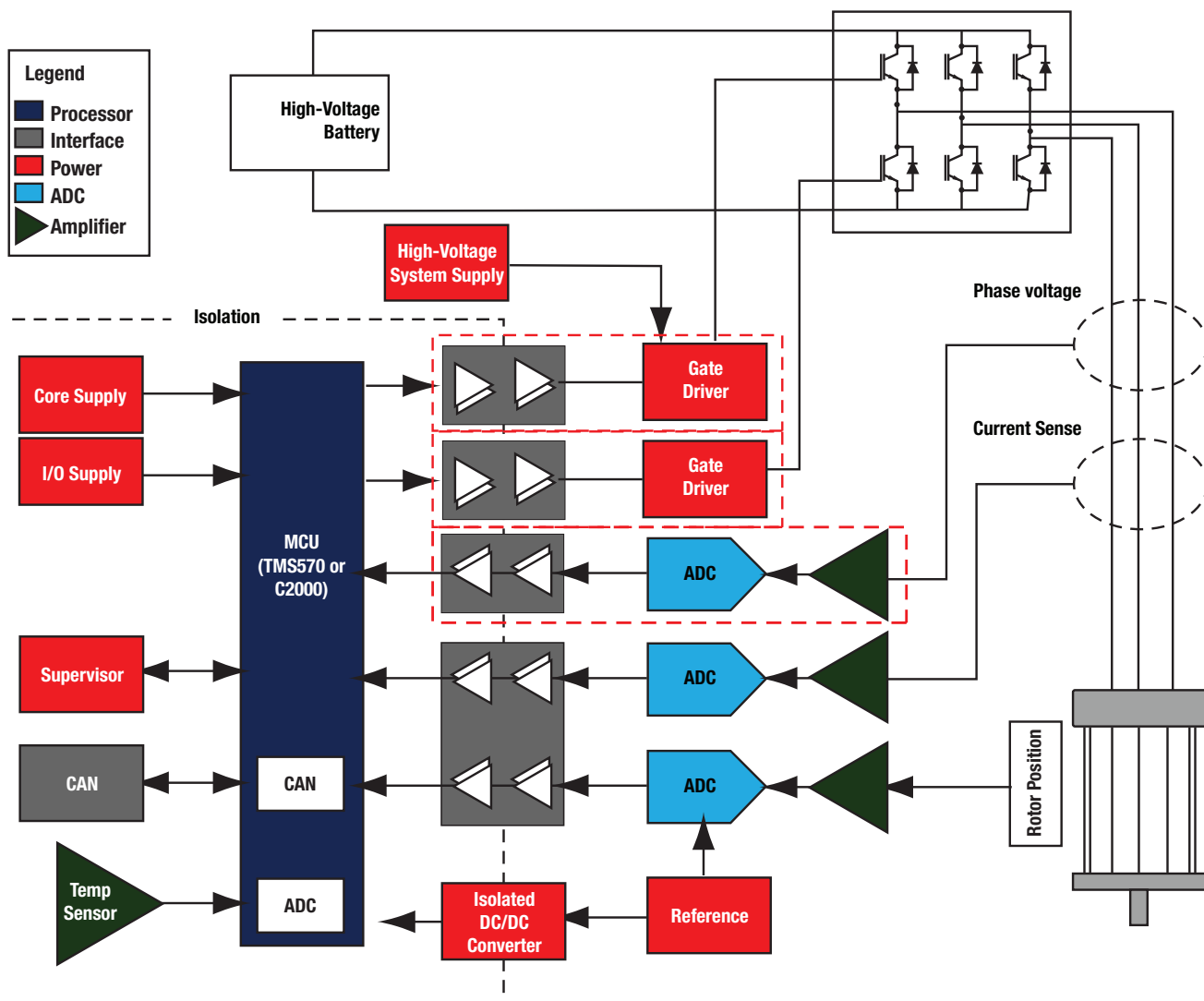

Motor Control

Safe Motor Control with TMS570 ARM® Cortex™-R4F

TMS570 Microcontroller

TMS570 MCU motor control benefits

32-bit ARM Cortex-R4F with floating-point unit

- IEEE 754-compliant floating-point unit (ARM VFPv3D16)
 - Supports both single and double precision

Timer coprocessor – high-end timer (HET)

- Effective support of many different motor control concepts due to HET programmability
 - PWM generation – symmetric, asymmetric, deadband
 - Single- or multiple-shunt systems
 - Quadrature decoding
 - HET can trigger the ADC(s) with many configuration possibilities

Dual 12-bit buffered ADCs

- 12-bit resolution SAR
- 400-ns conversion time / 200-ns sampling time
- 24 total channels (MibADC1 = 8, MibADC2 = 8, Shared = 8)
 - Shared channels can be used for oversampling using both ADCs
 - Continuous multichannel or single-channel conversion modes

TMS570 key features

ARM Cortex-R4F CPU

- Up to 160 MHz with floating-point support
- Dual CPUs in lockstep

Memory

- Flash: 1 MB and 2 MB with ECC protection
- RAM: 128 KB and 160 KB with ECC protection
- Roadmap from 768-KB to 4-MB flash

Peripheral highlights

- FlexRay with 8-KB message RAM
- Three CAN interfaces
- Three Multibuffered SPI (MibSPI)
- Two UARTs – both with LIN 2.1
- Two 12-bit buffered ADCs (MibADC)
- Flexible timer module with up to 32 channels
- Trace and calibration interfaces

Packages

- 144 QFP, 337 nFBGA (16 × 16 mm)

TMS570 enables safe motor control

The TMS570 microcontroller family enables customers to easily build safety-related motor control applications. Devices are available today with up to 160 MHz of floating-point performance and an integrated safety concept.

A wide choice of communication peripherals like CAN, FlexRay and LIN – in combination with a powerful timer coprocessor module – (HET) makes the family a flexible solution for safety-critical control applications.

Learn more at: www.ti.com/TMS570

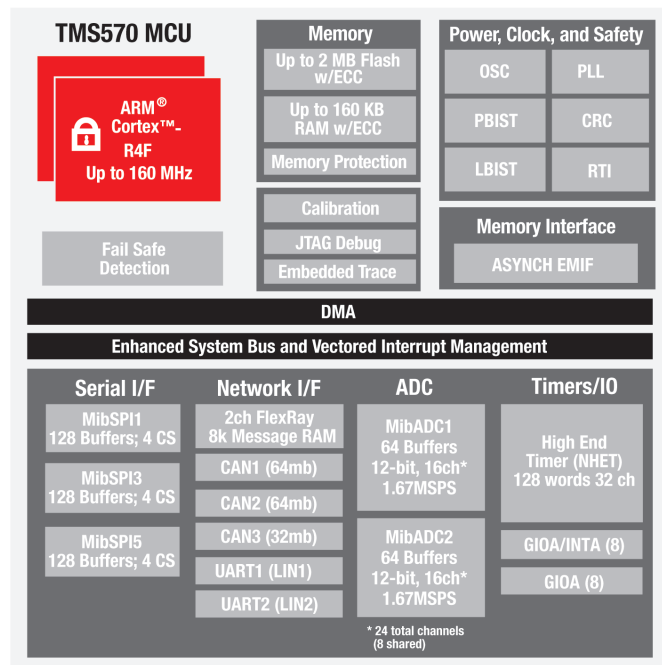
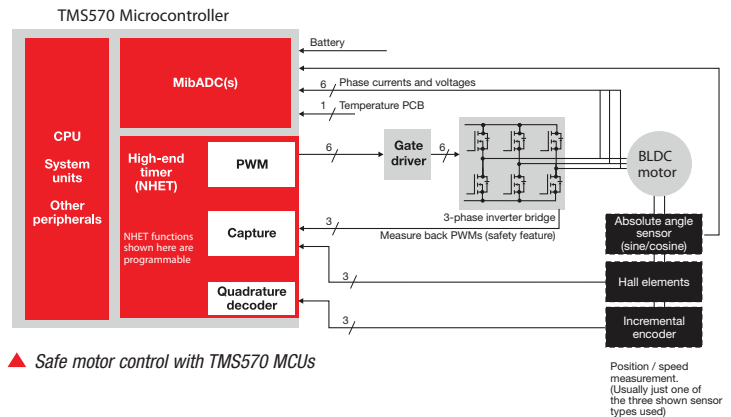

Motor Control

Safe Motor Drive with DRV32xx family

Key Features

- Built-in diagnostics: The DRV32xx-Q1 family integrates hard-wired diagnostic circuits including a pre-FET driver short, over/under voltage and over temperature. The system's microcontroller can quickly communicate with the DRV32xx-Q1 family and monitor internal status through serial peripheral interface (SPI).
- Devices help customers design applications to meet the functional safety requirements of ISO 26262: DRV3201-Q1 can help TI customers design critical-safety applications, such as electric power steering and electric braking systems, to meet ASIL-D requirements, and the DRV3204-Q1 and DRV3203-Q1 can help customers design safety applications, such as oil pump and water pump, to meet the ASIL-B requirements.
- Design simplicity for start-stop and cold crank applications: With an integrated boost regulator, the DRV3201-Q1 eliminates the need for a large capacitor to hold battery voltage. With an integrated low drop-out linear regulator (LDO) and an external FET, the DRV3203-Q1 and DRV3204-Q1 also eliminate the need for a large capacitor or external boost regulator. This integration simplifies design and speeds up development time.
- Optimized component count and board space for cost- and space-sensitive applications: The DRV3202-Q1 integrates a voltage regulator and CAN Interface to reduce component count and minimize system cost and board space.

DRV32xx Product Overview

Function	DRV3201	DRV3204	DRV3203	DRV3210	DRV3202	DRV3211
Gate Driver Stage	140 mA to 1 A, programmable current sources	1 A gate driver switches	1 A gate driver switches	1 A gate driver switches	1 A gate driver switches	1 A gate driver switches
Current Sense Amplifiers	2 ch, low side	1 ch, high side	1 ch, high side	1 ch, high side	1 ch, high side	1 ch, high side
Short protection	VDS	High side over current, phase comparator	High side over current, phase comparator	High side over current, phase comparator	High side over current, phase comparator	High side over current, phase comparator
Watchdog	No watchdog	Pulse, WD input	Pulse, WD input	Pulse, WD input	Pulse, WD input	Pulse, WD input
Phase comparators	Three phase comparators	Three phase comparators	Three phase comparators	Three phase comparators	Three phase comparators	Three phase comparators
Voltage Monitoring	VS	VB,VCC5	VB,VCC3	VB,VCC5	VB,VCC5	VB,VCC5
Others	ASIL D system target	5 V MCU LDO	3.3 V MCU LDO	5 V low power MCU LDO	CAN, 5 V MCU LDO	5 V MCU LDO
Maximum Supply Voltage	40 V	40 V	40 V	40 V	40 V	40 V
Maximum Operating Temperature	Ta = 125°C	Ta = 125°C Ta = 150°C option	Ta = 12°C Ta = 150°C option	Ta = 125°C	Ta = 125°C	Ta = 125°C
Package	64-pin HTQFP PowerPADTM	48-pin HTQFP PowerPADTM	48-pin HTQFP PowerPADTM	48-pin HTQFP PowerPADTM	80-pin HTQFP PowerPADTM	80-pin HTQFP PowerPADTM
Target application	EPS, Brake, Pumps, Transmission	Transmission, Pumps, FAN	Transmission, Pumps, FAN	Transmission, Pumps, FAN	Transmission, Pumps, FAN	Transmission, Pumps, FAN

Learn more at: www.ti.com/automotordriver

Motor Control

Safe Motor Drive with DRV32xx family

Key Features

- 3 phase pre-FET drivers
- Programmable 140 mA to 1 A gate current drive
- Gate driver with low supply voltage operation with integrated boost converter
- 2 Modes of gate drivers
 - Direct mode (6 x inputs)
 - PWM mode to 20 KHZ, 100% duty operation (3 x inputs)
- High accuracy current sense amplifiers (2 ch)
- Real time phase comparator (3 ch)

- Shoot through protection
- Pre-FET driver short circuit protection
- Over-/Under-voltage protection
- Over temperature warning and shut down
- AEC-Q100 grade-1 (-40°C to 125°C)

- Operating supply voltage: 4.75 V to 30 V
- 3.3 V/5 V MCU interface
- -7 V to 40 V tolerance for all FET driver pins
- Logic functional down to 3 V
- Package: 64-pin HTQFP PowerPAD™

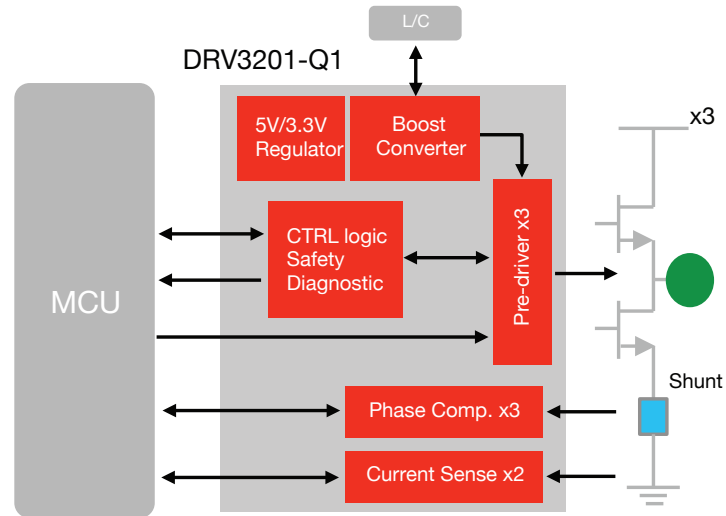

DRV3201 Development Tools

DRV3201EVM (\$499)

The Texas Instruments DRV3201 evaluation module (DRV3201EVM) helps designers evaluate the operation and performance of the DRV3201-Q1 bridge driver for electronic power steering applications. The DRV3201EVM can accept many of the TI Micro-Control Unit (MCU) Control Cards. The device with the MCU offers configurability and can turn a motor via a Graphical User Interface (GUI).

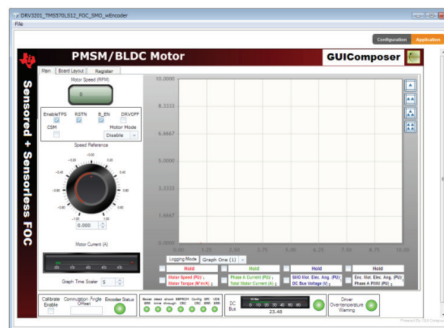

Key Features

- Max 1 A (programmable) pre-drive with 2x Internal programmable gain amplifiers for shunt current sensing
- Operating supply voltage 4.75 V to 30 V
- 5-V step down converter(2.5-A) and 3.3 V LDO (400-mA)
- Six N-channel MOSFETs
- Isolated 5-V controller area network (CAN) transceiver
- DIMM-100 socket using control card of Texas Instruments
- Sockets for sensor input

Learn more at: www.ti.com/automotordriver

Motor Control

Introduction to Functional Safety

TMS570 Built-In SIL3 Certified Safety Concept

The TMS570 family is specifically designed to meet IEC61508 SIL3 for safety critical applications like HEV/ EV. A SIL3 certificate and the required documentation are available. A dual CPU lockstep architecture simplifies development while eliminating redundant system requirements to reduce cost. CPU hardware built-in self test (BIST) detects latent defects without complex safety drivers or code size overhead. Hardware comparison of CPU outputs provides exceptional safety response time without additional software overhead. An enhanced ECC logic is integrated in the CPU to protect both memories and buses. All memories can be tested using hardware BIST for high diagnostic coverage and an integrated memory protection unit (MPU) protects against deterministic errors in application software.

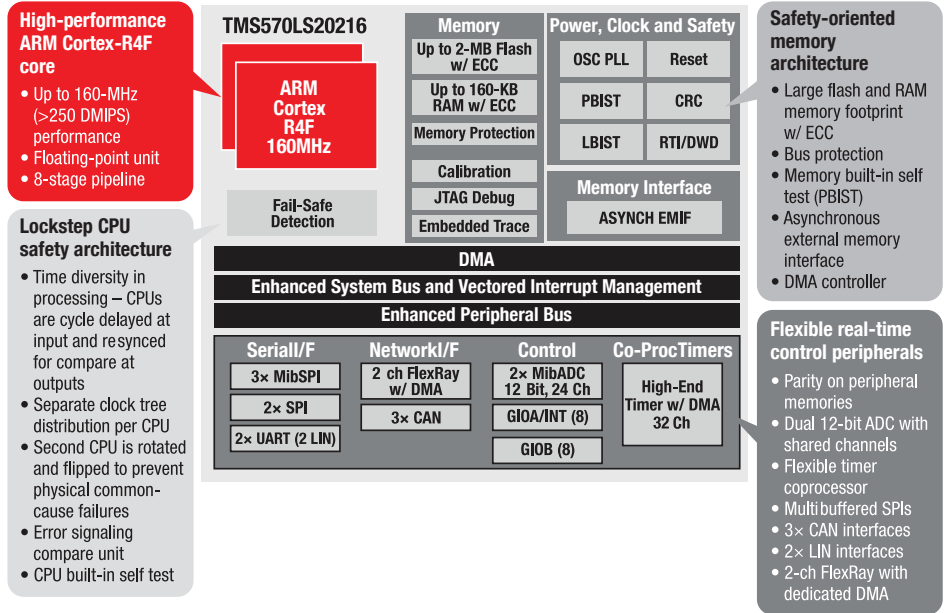

Certified safety

The TMS570 family was assessed by exida to the IEC 61508 safety standard and certified that the device family is suitable for use in SIL3 based systems.

The complete TMS570 Safety Manual with FMEDA, FIT rates and several guidelines how to make the safety implementation as easy as possible is available on demand.

The TMS570 family is used in a variety of safety related automotive applications like braking and steering – a safe choice.



Motor Control

Safe Motor Control using TPS65381-Q1

TPS65381-Q1 Power Management Unit for Safety MCUs

The TPS65381-Q1 device is a power management unit for safety MCUs meeting ASIL-D safety level requirements. It is ideally suited for automotive as well as industrial safety applications, such as electric power steering (EPS), braking, transmission and industrial motor control. It is qualified for Automotive Applications according to AEC-Q100.

Since the TPS65381 fulfills ASIL-D (ISO26262) safety level and provides a high level of integration of all main power rails required by safety MCUs in safety systems, it enables easy implementation and quick verification of functional safety in a small footprint.

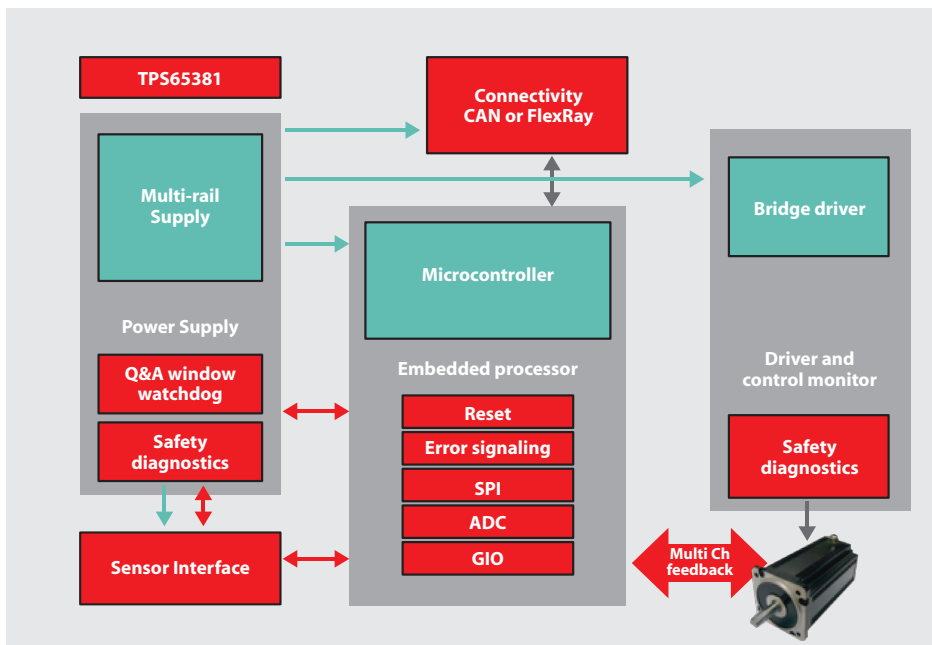

Key Features

- Multi-rail power supply supporting among others
- Supply rails:
 - Input voltage range:
- 5.8 V to 36 V (CAN, I/O, MCU core, and sensor supply regulators functional)
- 4.5 V to 5.8 V (3.3-V I/O and MCU core voltage functional)
- Power supply/system monitoring:
 - Under- and Over-voltage monitoring on all regulator outputs, battery voltage, and internal supplies
 - Self-check on all voltage monitoring (during power up and after power up initiated by external MCU)
- Microcontroller Interface
- SPI Interface
- Package: 32-pin HTSSOP PowerPAD™ package

Motor Control

Safe Motor Control with TMS570 ARM Cortex-R4F

TMS570 MCU Development Tools

TMDX570LS20SUSB (\$79)

Low-cost TMS570 evaluation kit

- USB powered
- Onboard USB XDS100 JTAG debug
- Onboard SCI-to-PC serial communication
- Access to select signal pin test points
- LEDs, temp sensor, light sensor and CAN transceiver
- TMS570 in QFP package
-



TMDX570LS20SMDK (\$695)

Full-featured TMS570 microcontroller development kit

- Separate CPU card and IO card
- XDS100 emulator onboard
- External high-speed emulation via JTAG
- TRACE connectors for ETM/RTP/DMM
- Interfaces: FlexRay/CAN/LIN transceivers
- Color touch-screen TFT
- TMS570 in BGA package



Software included in both kits:

- Code Composer Studio™ IDE
- Includes C/C++ compiler/linker/debugger
- HalCoGen peripheral driver generation tool
- Flash programming integrated
- Demo projects
- Code examples



Learn more at: www.ti.com/TMS570

Motor Control

Safe Motor Control with TMS570 ARM Cortex-R4F

TMS570 Product Overview

Device	Speed (MHz)	Flash	RAM (KB)	Data Flash (KB)	EMAC	FlexRay™	CAN	MiBSPi (cs)	SPI (cs)	I ² C	UART (LIN)	HET (ch)	PWM (ch)	CAP/QEP	MiBADC 12 bit (ch)	EMIF (16 bit)	Total GPIO (interrupt)	TRACE (ETM/RTP/DMM)	Package	Temperature Range (°C)
TMS570LS04x/03x series																				
TMS5700332PZQQ1	80	256KB	32	16	–	–	2	1(4)	2(8)	–	1(1)	19	–	–/2	1(16)	–	45(8)	–	100 QFP	–40 to 125
TMS5700432PZQQ1	80	384KB	32	16	–	–	2	1(4)	2(8)	–	1(1)	19	–	–/2	1(16)	–	45(8)	–	100 QFP	–40 to 125
TMS570LS12x/11x series																				
TMS5701114PGEQQ1	160	1MB	128	64	–	–	3	3(12)	1(1)	1	2(1)	2(40)	14	6/2	2(24)	–	64(10)	–	144QFP	–40 to 125
TMS5701114ZWTQQ1	180	1MB	128	64	–	–	3	3(16)	2(3)	1	2(1)	2(44)	14	6/2	2(24)	Yes	101(16)	–	337BGA	–40 to 125
TMS5701115PGEQQ1	160	1MB	128	64	–	2 ch	3	3(12)	1(1)	1	2(1)	2(40)	14	6/2	2(24)	–	58(4)	–	144QFP	–40 to 125
TMS5701115ZWTQQ1	180	1MB	128	64	–	2 ch	3	3(16)	2(3)	1	2(1)	2(44)	14	6/2	2(24)	Yes	101(16)	–	337BGA	–40 to 125
TMS5701224PGEQQ1	160	1.25MB	192	64	–	–	3	3(12)	1(1)	1	2(1)	2(40)	14	6/2	2(24)	–	64(10)	–	144QFP	–40 to 125
TMS5701224ZWTQQ1	180	1.25MB	192	64	–	–	3	3(16)	2(3)	1	2(1)	2(44)	14	6/2	2(24)	Yes	101(16)	–	337BGA	–40 to 125
TMS5701225PGEQQ1	160	1.25MB	192	64	–	2 ch	3	3(12)	1(1)	1	2(1)	2(40)	14	6/2	2(24)	–	58(4)	–	144QFP	–40 to 125
TMS5701225ZWTQQ1	180	1.25MB	192	64	–	2 ch	3	3(16)	2(3)	1	2(1)	2(44)	14	6/2	2(24)	Yes	101(16)	–	337BGA	–40 to 125
TMS5701227PGEQQ1	160	1.25MB	192	64	10/100	2 ch	3	3(12)	1(1)	1	2(1)	2(40)	14	6/2	2(24)	–	58(4)	–	144QFP	–40 to 125
TMS5701227ZWTQQ1	180	1.25MB	192	64	10/100	2 ch	3	3(16)	2(3)	1	2(1)	2(44)	14	6/2	2(24)	Yes	101(16)	–	337BGA	–40 to 125
TMS570LS31x/21x series																				
TMS5702124APGEQQ1	160	2MB	192	64	–	–	3	3(12)	1(1)	1	2(1)	2(40)	–	–	2(24)	–	64(10)	–	144QFP	–40 to 125
TMS5702124AZWTQQ1	180	2MB	192	64	–	–	3	3(16)	2(3)	1	2(1)	2(44)	–	–	2(24)	Yes	120(16)	Yes	337BGA	–40 to 125
TMS5702125APGEQQ1	160	2MB	192	64	–	2 ch	3	3(12)	1(1)	1	2(1)	2(40)	–	–	2(24)	–	58(4)	–	144QFP	–40 to 125
TMS5702125AZWTQQ1	180	2MB	192	64	–	2 ch	3	3(16)	2(3)	1	2(1)	2(44)	–	–	2(24)	Yes	120(16)	Yes	337BGA	–40 to 125
TMS5702134APGEQQ1	160	2MB	256	64	–	–	3	3(12)	1(1)	1	2(1)	2(40)	–	–	2(24)	–	64(10)	–	144QFP	–40 to 125
TMS5702134AZWTQQ1	180	2MB	256	64	–	–	3	3(16)	2(3)	1	2(1)	2(44)	–	–	2(24)	Yes	120(16)	Yes	337BGA	–40 to 125
TMS5702135APGEQQ1	160	2MB	256	64	–	2 ch	3	3(12)	1(1)	1	2(1)	2(40)	–	–	2(24)	–	58(4)	–	144QFP	–40 to 125
TMS5702135AZWTQQ1	180	2MB	256	64	–	2 ch	3	3(16)	2(3)	1	2(1)	2(44)	–	–	2(24)	Yes	120(16)	Yes	337BGA	–40 to 125
TMS5703134APGEQQ1	160	3MB	256	64	–	–	3	3(12)	1(1)	1	2(1)	2(40)	–	–	2(24)	–	64(10)	–	144QFP	–40 to 125
TMS5703134AZWTQQ1	180	3MB	256	64	–	–	3	3(16)	2(3)	1	2(1)	2(44)	–	–	2(24)	Yes	120(16)	Yes	337BGA	–40 to 125
TMS5703135APGEQQ1	160	3MB	256	64	–	2 ch	3	3(12)	1(1)	1	2(1)	2(40)	–	–	2(24)	–	58(4)	–	144QFP	–40 to 125
TMS5703135AZWTQQ1	180	3MB	256	64	–	2 ch	3	3(16)	2(3)	1	2(1)	2(44)	–	–	2(24)	Yes	120(16)	Yes	337BGA	–40 to 125
TMS5703137APGEQQ1	160	3MB	256	64	10/100	2 ch	3	3(12)	1(1)	1	2(1)	2(40)	–	–	2(24)	–	58(4)	–	144QFP	–40 to 125
TMS5703137AZWTQQ1	180	3MB	256	64	10/100	2 ch	3	3(16)	2(3)	1	2(1)	2(44)	–	–	2(24)	Yes	120(16)	Yes	337BGA	–40 to 125

Note: Above reflects max configuration of each module – some functions are multiplexed.

Start/Stop Function

Introduction to Start/Stop

A start/stop system automatically shuts down and restarts an automobile's internal combustion engine to reduce the amount of time the engine spends idling, thereby improving fuel economy. This is most advantageous for vehicles that spend significant amounts of time waiting at traffic lights or that frequently come to a stop in traffic jams.

This feature is present in hybrid electric vehicles, but has also appeared in vehicles that lack a hybrid electric powertrain. For nonelectric vehicles (called micro hybrids), fuel economy gains from this technology are typically in the range of 5 to 10 percent. But because automobile accessories like air conditioners and water pumps

have typically been designed to run off a serpentine belt on the engine, these systems must be redesigned to function properly when the engine is turned off. Typically, an electric motor is used to power these devices instead.

Power Management for Start/Stop Function

More and more modules inside a car have to be defended from voltage drop during cranking. This problem has increased with the implementation of start/stop (micro hybrid) systems, a trend seen in the automotive industry to improve fuel efficiency.

TI offers a variety of products in the power management area that can solve this system/customer problem.

TI's solution

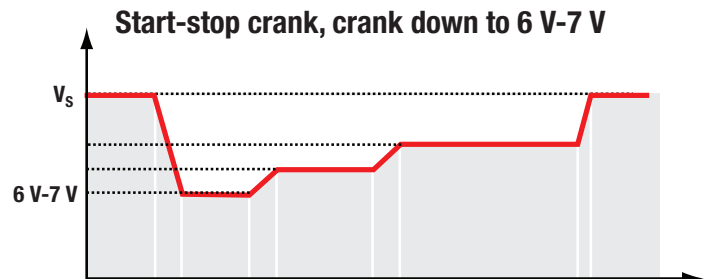
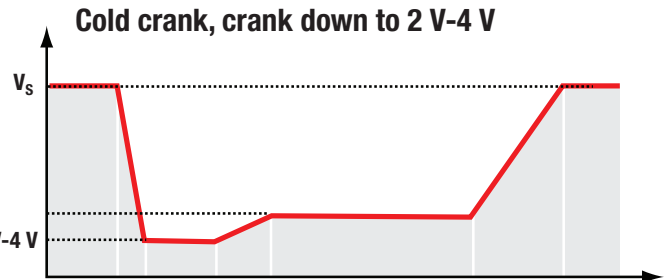
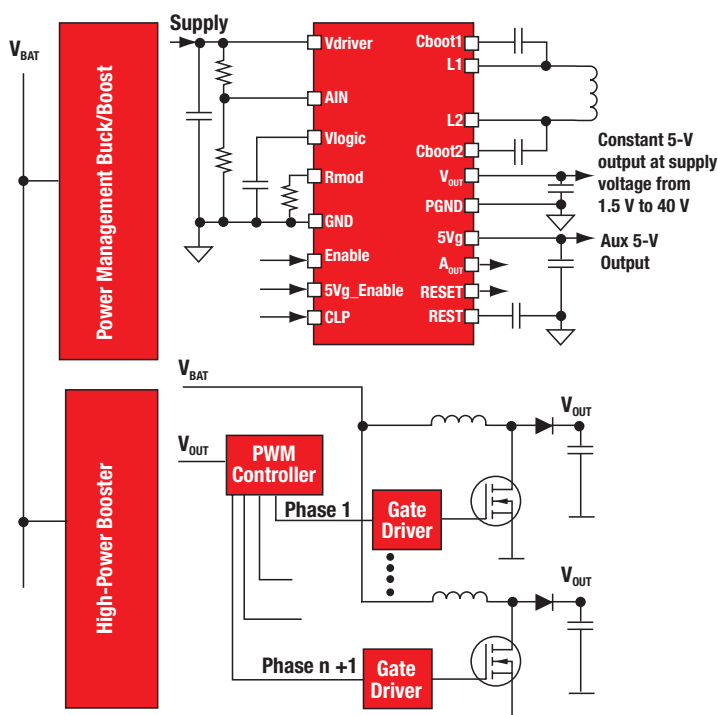

Start/Stop Function

Start/Stop Function Using TI Analog Products

TPS40210-Q1 Boost Converter

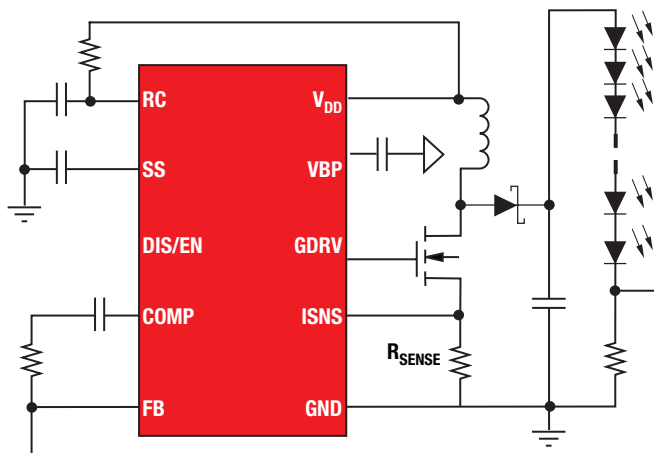

TPS40210-Q1 controller configured as a high-efficiency constant-current LED driver. EVM available

Key features

- Wide-input voltage range: 4.5 V to 52 V
- Current-mode controller
- TPS40210-Q1: internal reference voltage: 0.70 V
- Internal undervoltage lockout
- Programmable frequency 35 kHz to 500 kHz
- Frequency synchronization
- Closed-loop soft start
- Overcurrent protection
- Integrated NMOS-FET driver
- Small package size: 10-pin MSOP

Benefits

- Suitable for any type of boost application
- Boost, flyback and SEPIC topologies possible

Learn more at: www.ti.com/sc/device/TPS40210-Q1

TPIC74100-Q1 Buck-Boost-Converter Integrated Switches

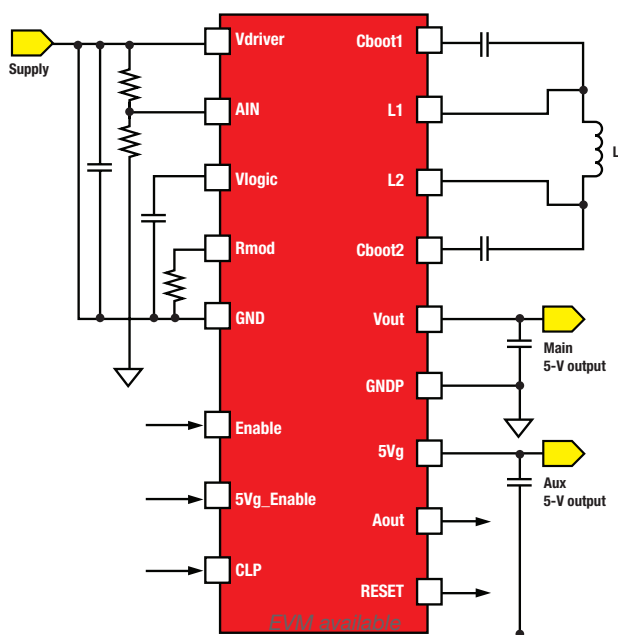

Key features

- Wide-input voltage range: 1.5 V to 40 V
- Max. load current: 1 A (TPIC74100-Q1) 500 mA (TPS55065-Q1)
- Max. load current: 200 mA @ VIN = 2.0 V
- Max. load current: 120 mA @ VIN = 1.5 V
- Fixed output voltage: 5 V
- Enable function, shutdown current < 20 μ A
- Switching frequency 440 kHz nom
- Slew-rate control and frequency modulation for EMI reduction
- Alarm function for undervoltage detection
- Switched 5-V output with current limit
- Thermally enhanced 20-pin PowerPAD™ package

Benefits

- Stable 5-V line, also during cranking pulse
- Wide-input voltage range, no external protection required
- Reset integrated, additional alarm threshold integrated
- Output voltage switched to second pin (auxiliary 5-V output)
- Designed for harsh automotive environments (protections for overtemperature, overvoltage)

Learn more at: www.ti.com/sc/device/TPIC74100-Q1

Start/Stop Function

Start/Stop Function Using TI Analog Products

TPS40090-Q1 Four-Channel Multiphase Buck DC/DC Controller (or Boost)

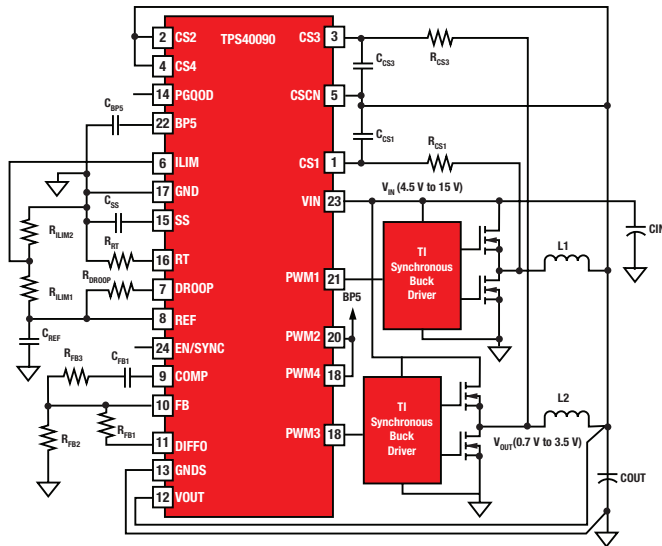

EVM available

Key features

- Qualified for automotive applications
- Two-, three- or four-phase operation
- 5-V to 15-V operating range
- Programmable switching frequency up to 1 MHz/phase
- Current-mode control with forced current sharing (1)
- 1 percent internal 0.7-V reference
- Resistive divider set output voltage
- True remote sensing differential amp
- Resistive or DCR current sensing
- Current-sense fault protection
- Programmable load line
- Compatible with TI's UCC37222 Predictive Gate Drive™ technology drivers
- 24-pin space-saving TSSOP package
- Binary outputs

Learn more at: www.ti.com/sc/device/TPS40090-Q1

LM5122 Wide Input Range Synchronous Boost Controller with Multiphase Capability

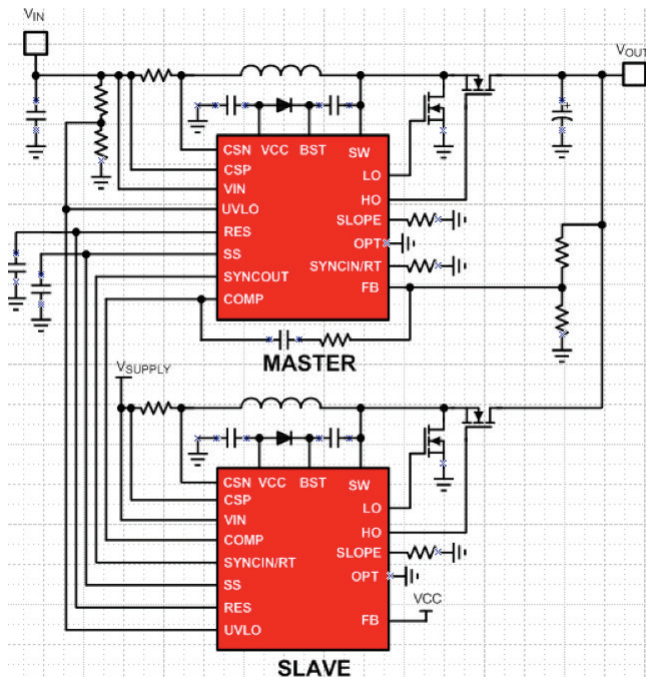

Key features

- Wide input voltage range: 3V to 65V
- Output voltage up to 100V
- Robust 3A integrated gate drivers
- Multi-phase capable
- Bypassing feature
- Free-run or synchronizable FSW to 1MHz
- Low shutdown IQ: 10uA
- Programmable slope compensation and skip cycle mode
- Programmable cycle-by-cycle current limit
- eTSSOP-20 package

Benefits

- Wide input/output range well suited for automotive applications
- Multiphase capability supports higher power requirements with flexibility
- Synchronous operation improves efficiency and power density

Learn more at: www.ti.com/sc/device/LM5122

Start/Stop Function

Start/Stop Function Using the C2000™ Piccolo™ MCU

Using a C2000™ MCU with enhanced real-time features brings both high-speed loop control and system management capabilities in a single device. The Piccolo MCU's math-efficient CPU, closely coupled with high-performance pulse-width modulators (PWMs) and ADCs, can control multiphase boost stages over a wide range of operating points. Digital control schemes with feed-forward, three-pole/three-zero compensators, PID, etc., allows power designers to realize complex and flexible loop control strategies that can be adaptive

and managed for efficiency, transient performance, light-load operation, fault handling and rich diagnostics.

Independent control of each phase allows for current balancing within each phase, spreading the load evenly and improving reliability. This also adds phase-shedding capability, where at light loads one or two phases are used, hence increasing efficiency.

Under these conditions, "intelligent" management software can retune control loops by dynamically changing compensator coefficients. The above

diagram shows a four-phase boost implementation where each MOSFET is controlled with a high-resolution PWM capable of 150-pS edge-placement accuracy, ensuring smooth PWM switching speeds from 100 KHz to beyond 500 KHz without the undesirable limit-cycle oscillations often associated with low-resolution PWMs.

Please contact your local sales office for kit information.

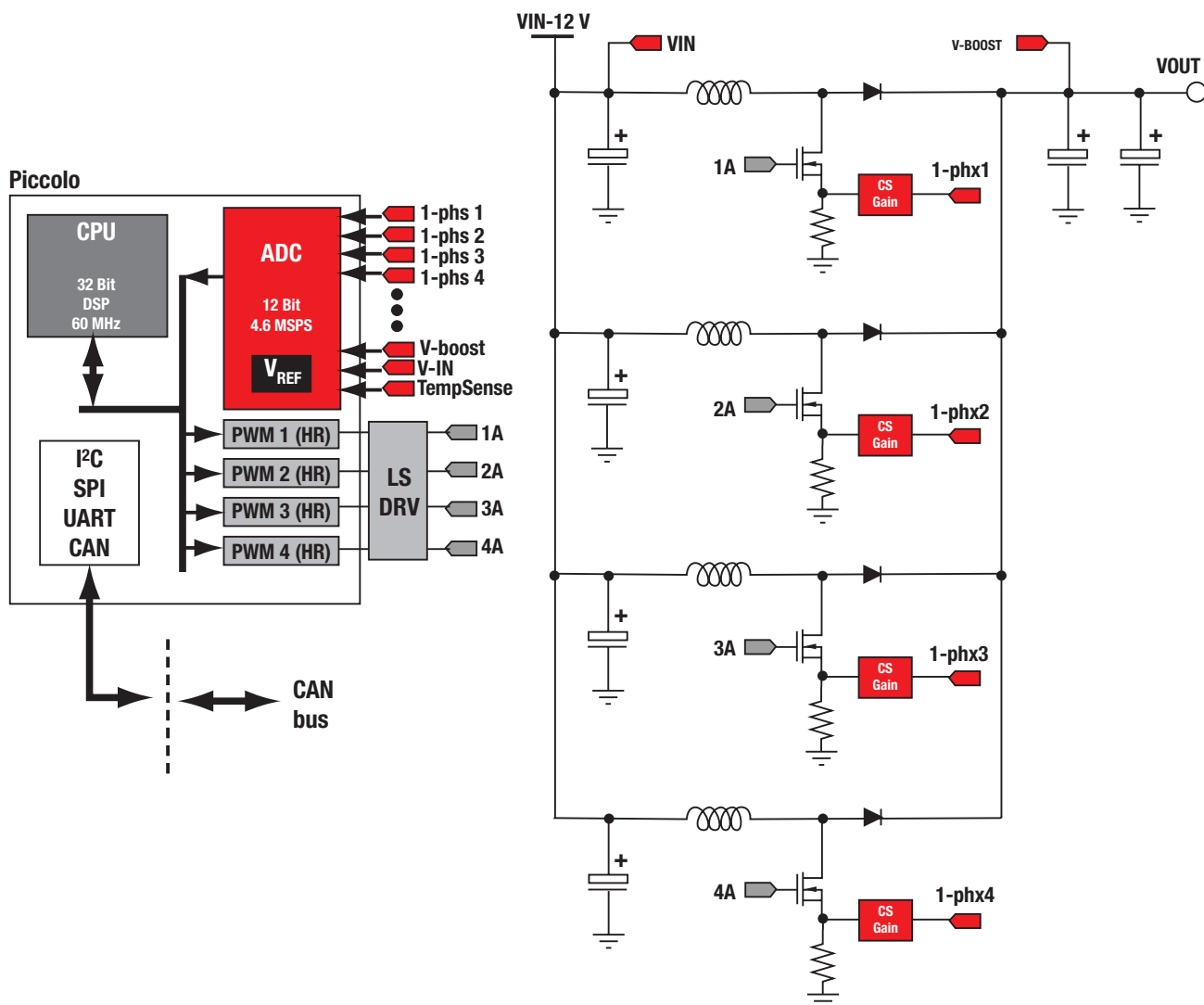

E-Bikes and Small Task-Oriented Vehicles (STOVs)

Introduction to E-Bikes and Small Task-Oriented Vehicles (STOVs)

Electric transportation is not only relevant for cars, but already used in many millions of simple task-oriented vehicles around the world. The systems are more basic compared to those on the hybrid and electric car side, but consist of the same functional blocks.

For motor control, the Piccolo™ MCU family is a good choice, offering the combination of a powerful CPU engine with the required PWM and ADC capabilities for the control loop at an economical price point. The battery

systems are typically operating at lower voltages with less cells, so integrated solutions like the bq77910 or bq77908 managing and protecting as many as 10 cells are a good fit.

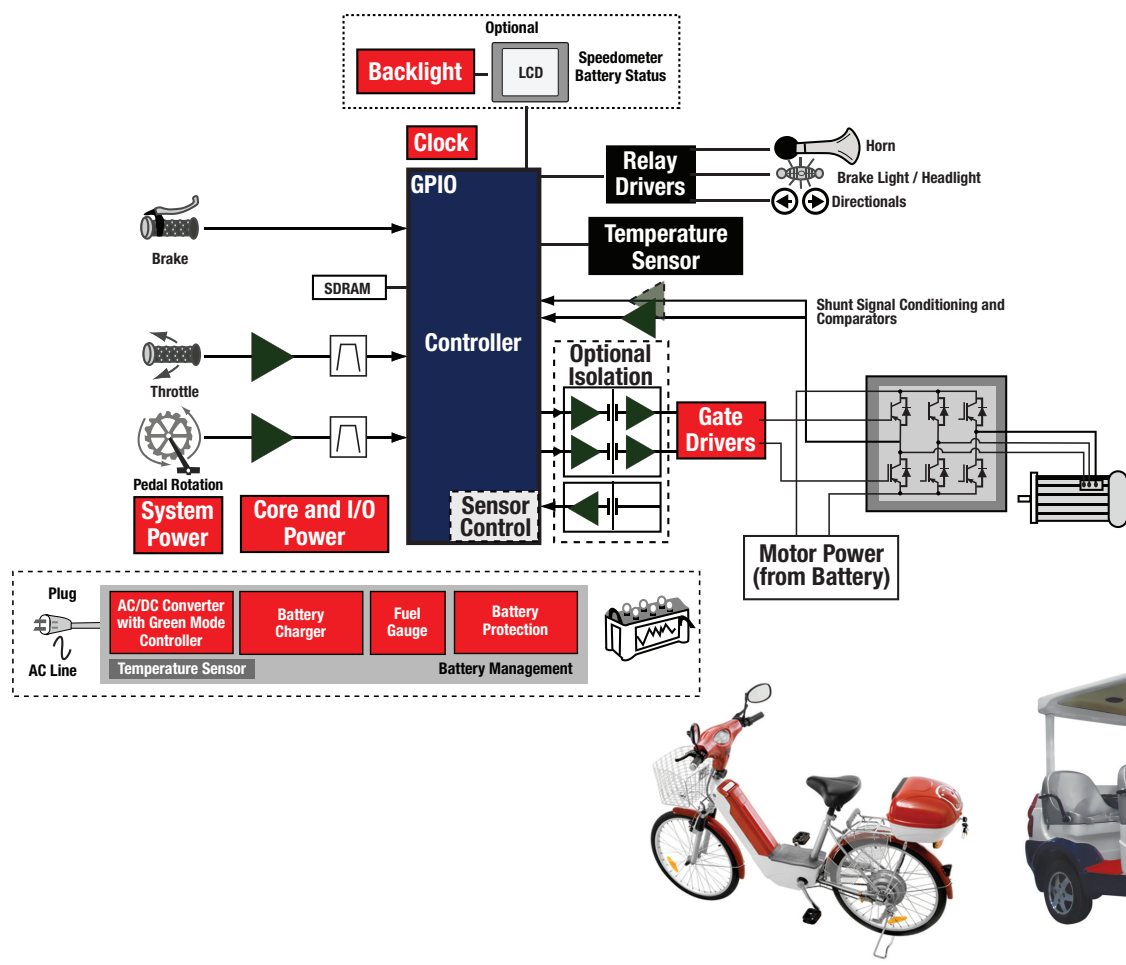

Selection Guide

Device	Number of Series Cells	Protection Method	Shutdown Current (µA)	Description	Package	Price*
bq77PL900	5 to 10	External PFET	—	Standalone or host-controlled protector with cell balancing	48-pin SSOP	\$2.95
bq77908	4 to 8	External NFET	5	Standalone protector with cell balancing (internal or external)	38-pin TSSOP	\$2.60
bq77910	4 to 10	External NFET	5	Standalone protector with cell balancing (internal or external)	38-pin TSSOP	\$2.70
bq77PL157A4225	3 to 6	External NFET or Fuse	3	Stackable overvoltage protection with FET or fuse output activation	16-pin TSSOP	\$0.65
bq78PL116	3 to 16	External PFET	1	Standalone high-power gas gauge with advanced protection and PowerPump™ cell balancing	48-pin QFN	\$4.50
bq76PL102¹	1, 2	—	1	Stackable Li-ion dual-cell expansion monitor and balancer for bq78PL116	16-pin QFN	\$0.90
bq76PL536AB	3 to 6	Integrated	12	Stackable battery monitor, protector and cell balancer for high-cell applications	64-pin TQFP	\$5.05
bq78412	—	N/A	—	Pb-acid battery state-of-charge indicator with run-time display	44-pin TSSOP	\$3.90

¹Controlled by bq78PL116 gas gauge. See individual datasheets for full details. *Suggested resale price in U.S. dollars in quantities of 1,000.

New devices are listed in bold red.

E-Bikes and Small Task Oriented Vehicles (STOVs)

STOV Products

bq78PL116 Integrated Gas Gauge, Protection and Active Cell Balancing Controller for Up to 16-Series Li-Ion Cells

Key features

- Three- to 16-series cell systems
- PowerPump™ technology cell balancing for longer run time and cell life
- Supports discharge current levels of 10 A, 35 A and 110 A
- Gauges up to 328-Ahr capacity batteries
- High resolution 18-bit integrating delta-sigma Coulomb counter for precise charge-flow measurements and gas gauging
- Multiple independent delta-sigma A/Ds: one-per-cell voltage, plus separate temperature, current and safety
- Fully programmable voltage, current, balance and temperature protection
- Remaining capacity indicators: LCD, LED, EPD

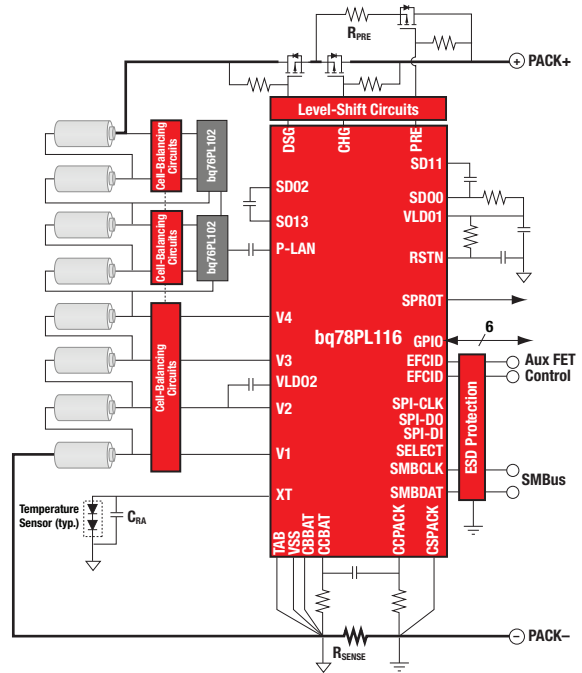

Learn more at: www.ti.com/sc/device/bq78PL116

bq76PL102 Dual-Cell Li-Ion Monitor with Active Cell Balancing

Key features

- Monitors up to two individual cell voltages and temperatures
- Part of a complete low-cost solution for battery packs of up to 16 series and one or more parallel cells (when used with bq78PL116)
- Advanced PowerPump™ balancing technology equalizes cells in Li-ion battery packs, resulting in longer run time and cell life
- PowerPump cell balancing transfers charge from cell to cell during all operating conditions – no wasteful current bleeding or associated heat buildup
- Unique PowerLAN isolated communications technology permits simultaneous measurement of all individual cell voltages in a series string
- Low current consumption:
 - <250- μ A active
 - <35- μ A standby
 - <1- μ A undervoltage shutdown

- Connects directly to cells, no resistive dividers
- Internal LDO regulator for support circuitry
- Ultra small footprint, 3 mm \times 3 mm
- Millivolt measurement resolution using delta-sigma ADC

Applications

- Uninterruptible power supply (UPS)
- Portable medical and test equipment
- Electric bikes and mild-EV battery packs
- Multicell series strings \geq 5S

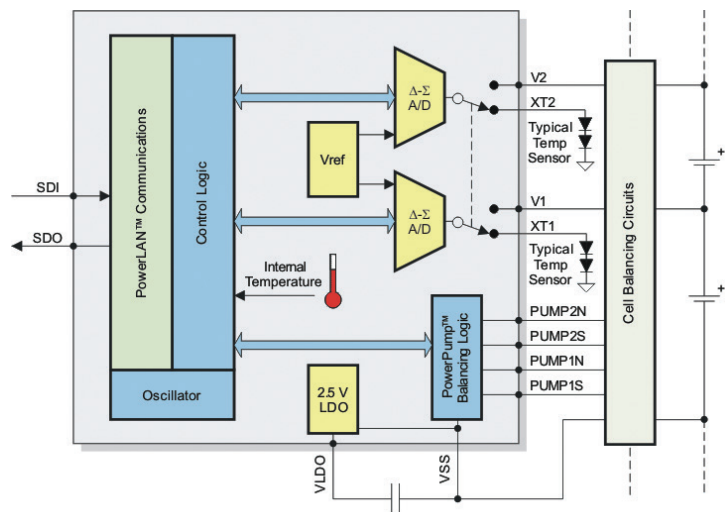

Learn more at: www.ti.com/sc/device/bq76PL102

E-Bikes and Small Task Oriented Vehicles (STOVs)

STOV Products

bq77PL900 Standalone and Host-Controlled Battery Protector for Five- to 10-Series Li-Ion Cells

Key features

- Five-, six-, seven-, eight-, nine- or 10-series cell primary protection
- PMOS FET drive for charge and discharge FETs
- Capable of operation with 1-m Ω sense resistor
- Supply voltage range from 7 V to 50 V
- Integrated 5-V, 25-mA LDO
- Standalone mode
 - Pack protection control and recovery
 - Individual cell monitoring
 - Integrated cell balancing
- Programmable threshold and delay time for:
 - Overvoltage
 - Undervoltage
 - Overcurrent in discharge
 - Short circuit in discharge
- Fixed overtemperature protection
- Host control mode
 - I2C interface to host controller
 - Analog interface for host cell measurement and system charge/discharge current
 - Host-controlled protection recovery
 - Host-controlled cell balancing

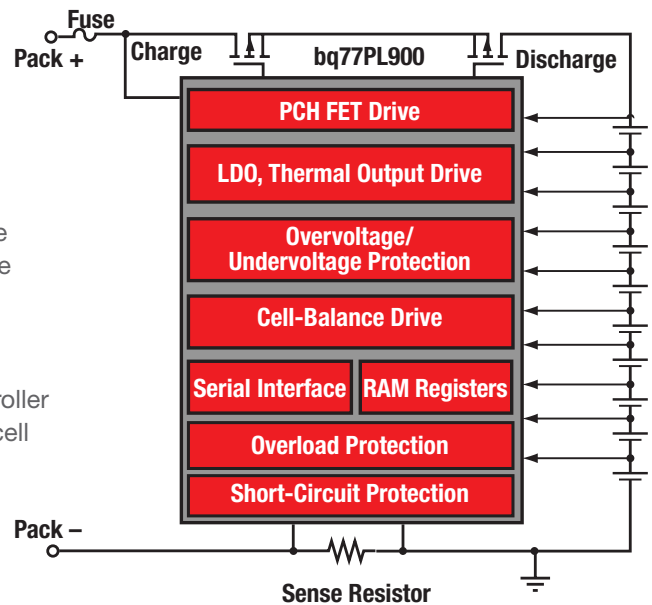

Learn more at: www.ti.com/sc/device/bq77PL900

bq77910 and bq77908 Standalone Precision Protector for Four- to 10-Series Li-Ion/Phosphate Cells

The bq77910 precision protector is a complete standalone, self-contained battery-protection and cell-balancing device intended for Li-ion/Li-polymer battery packs.

The bq77910 monitors four- to 10-series individual cell voltages and provides fast-acting outputs that can be used to drive n-channel MOSFETs to interrupt the power path. Activation delays and recovery methods for each safety condition are fully programmable in nonvolatile memory.

Key features

- Four-, five-, six-, seven-, eight-, nine- or 10-series cell protection
- Individual cell-voltage monitoring
- Low-side NMOS FET drive for charge and discharge control
- Compatible with 1-mW current-sense resistor
- Supply-voltage range: 5.6 V to 50 V
- Integrated 3.3-V micropower LDO regulator
- Internal 50-mA automatic cell balancing
- Low power consumption: 50- μ A operating, 5- μ A shutdown
- bq77908 is identical but for four- to eight-series cells only

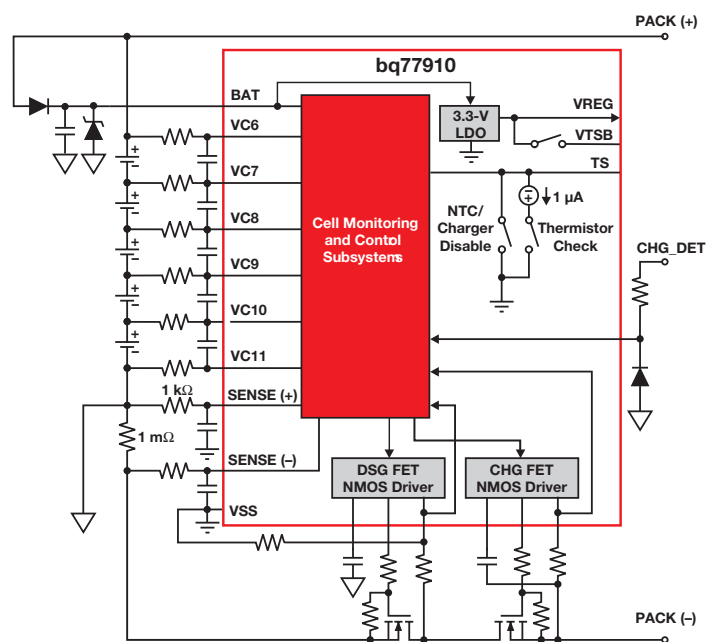

Five-cell series FET configuration schematic using the bq77910

Learn more at: www.ti.com/sc/device/bq77910 or [/bq77908](http://www.ti.com/sc/device/bq77908)

E-Bikes and Small Task Oriented Vehicles (STOVs)

STOV Products

bq78412 Pb-Acid Battery State-of-Charge Indicator with Run-Time Display

Key features

- Programmable models for cell formulations
- Capacity up to 327 Ah
- 10-LED bar graph capacity display of run-time and percent capacity
- Records cumulative usage data for warranty return analysis
- Data interface for usage data access via UART or InfraRed (IrDA)
- State-of-health determination and status reporting
- Configurable audible indicator for low-capacity, low-voltage or overvoltage warnings
- Supports high-side or low-side current shunt
- Addressable commands for multibattery systems
- Works with single 12-V mono-blocks or external divider permits use with 24-V, 36-V, 48-V and higher blocks
- On-chip temperature sensor

Learn more at: www.ti.com/sc/device/bq77PL900

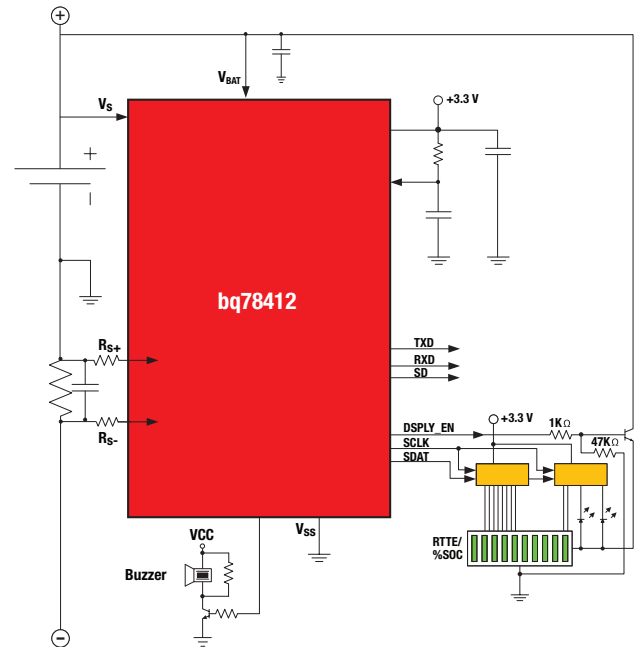

bq77PL157A Stackable Overvoltage Protector for Three- to Six-Series Li-Ion Cells

Key features

- Three-, four-, five- or six-cell overvoltage protection
- Stackable to 18 or more series Li-ion cells
 - No extra components to stack (no Iso/Optos)
- Low power <2.5-μA typical
- Internal noise filter with external capacitor to set activation delay
- Recoverable or permanent latch output options
- High accuracy sensing: +/-20-mV per cell
- Factory-programmed thresholds: 3.75 V to 4.35 V
 - No programming required
- No single pin open or adjacent pin short can prevent failsafe operation

Learn more at: www.ti.com/sc/device/bq77PL157A

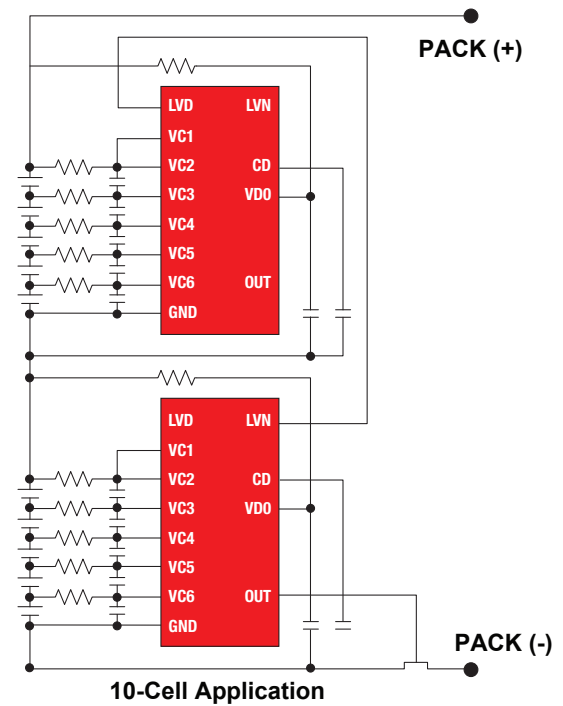

E-Bikes and Small Task Oriented Vehicles (STOVs)

STOV Products

DRV8312-C2-KIT Motor Driver ICs

The DRV8312-C2-KIT is a high-performance, power-efficient, cost-effective sensorless field-oriented control (FOC) and trapezoidal commutation platform that spins motors out of the box, speeding development for quicker time to market. Applications include sub-50-V and 6.5-A brushless motors for driving medical pumps, gates, lifts and small pumps, as well as industrial and consumer robotics and automation. For more information or to place an order, visit www.ti.com/drv8312-c2-kit-pr.

Key Features

- Out-of-the-box motor control and driver solution includes the DRV8312 motor driver, a 32-bit C2000™ Piccolo™ microcontroller (MCU) controlCARD™ module, a quick-start GUI, full development source code,

Code Composer Studio™ integrated development environment (IDE) and a three-phase BLDC motor.

- Flexible control platform that supports sensorless FOC and sensorless and sensed trapezoidal commutation control for rapid evaluation and development of three-phase motors. By adding a separate shaft encoder, the DRV8312-C2-KIT can also support sensed FOC.
- DRV8312 three-phase, fractional-horsepower motor driver provides the highest current output in its class, delivering up to 6.5 A without the need for a costly external heat sink. Its intelligent gate drive circuitry minimizes dead time to 5 ns, providing high linearity and maximizing motor performance. The DRV8312 motor driver is robust,

reliable and fully protected with cycle-by-cycle overcurrent, over-temperature, cross-conduction and undervoltage protection, reducing design complexity and board space and ensuring higher system reliability.

- The C2000 Piccolo MCU performs control, communications and debugging. The industry-leading 32-bit C2000 MCU integrates the most advanced analog feedback, digital control peripherals and CPU capability in an embedded MCU device family starting under \$2. This includes access to the most thorough set of motor control software modules, real-time debugging capabilities and open-tooled reference designs via free ControlSuite™ software.

Learn more at: www.ti.com/sc/device/DRV8312-C2-KIT

DRV8301 Brushless DC Motor Pre-Driver with Dual-Shunt Amplifiers and a Buck Converter

The DRV8301 is a gate driver IC for three-phase motor drive applications. It provides three half-bridge drivers, each capable of driving two N-type MOSFETs, one for the high side and one for the low side. It supports up to 2.3-A sink and 1.7-A source peak current capability and only needs a single power supply with a wide range from 8 to 60 V. The DRV8301 includes two current shunt amplifiers for accurate current measurement. The DRV8301 also has an integrated switching-mode buck converter with adjustable output and switching frequency to support MCU or additional system power needs.

Key features

- Gate driver with 8- to 60-V supply voltage and 1.7-A gate current drives up to 60-A external FETs
- Dual-shunt current-sense amplifiers
- Integrated buck converter with 3.5- to 60-V input, adjustable output, up to 1-A load
- Bootstrap structure with trickle charge
- Intelligent gate driver and cross-conduction prevention
- OC protection of external FETs with programmable cycle-by-cycle current limit
- Independent control of six external MOSFETs
- SPI interface for programmability

Applications

- PMSM and BLDC motors
- CPAP
- E-bike
- Power tools

Learn more at: www.ti.com/sc/device/DRV8301

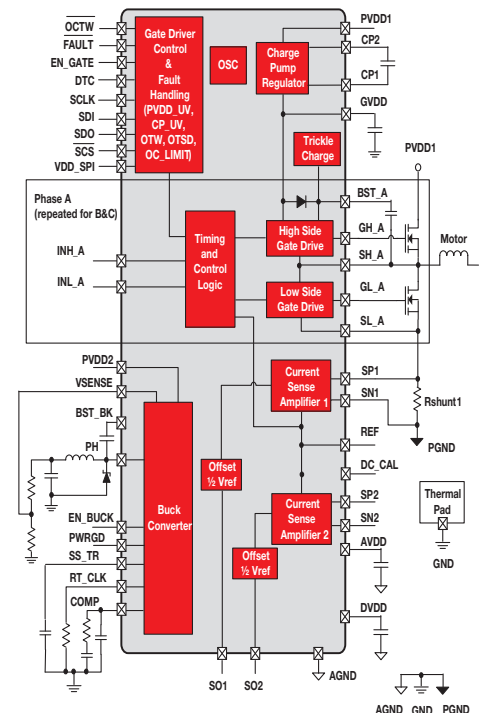

DRV8301 simplified application diagram

E-Bikes and Small Task Oriented Vehicles (STOVs)

STOV Products

Digital Motor Control for E-Bikes, Scooters and STOVs Evaluation Module

The C2000™ MCU platform of real-time controllers has been the industry leader in digital motor control since the inception of the TMS320F24x generation in 1996. Debuted in 2000, the F281x series is based on the C28x™

MCU engine, becoming the first 32-bit architecture specifically built for high-performance, math-intensive power electronics control. Based on the C28x MCU, this code-compatible family of devices meet application needs across performance, price,

pinout and peripherals. To find out more, visit www.ti.com/c2000dmc.

C2000™ High-Voltage PFC and Motor Control Developer Kit

Key features

- Piccolo™ MCU-based power factor correction (PFC) and motor control integrated into one development platform
- Support for three brushless motor types, AC induction, permanent magnet
- Synchronous motor, brushless DC motor
- 1-kW motor driver stage accepting up to 400 V
- 700-W PFC stage (line-level AC input ~110 to ~240 VAC)
- Open-source software for power factor correction stage
- Open-source software for control of all three motor types
- Open-source hardware, including schematics, BOM and gerber files
- Motors of each type available separately from TI
- Available for \$599
- Order part number: TMDSHVMTRPFCKIT



Learn more at: www.ti.com/sc/device/c2000tools

Microcontroller

Microcontroller Product Overview

C2000™ Microcontrollers

Device	Speed (MHz)	VCU	DMA	CLA	RAM (KB)	Flash (KB)	ROM (KB)	PWM Channels	HiRes PWM	Quadrature Encoder	Event Captures	Timers*	12-Bit ADC Channels/Conversion Time (ns)	Mc-BSP	I ² C	UART/SCI	SPI	Lin	CAN	External Memory Bus (bit)	Core Supply (volts)	GPIO Pins	On-Chip Oscillator/Regulator	Package
Piccolo™ MCUs																								
TMS320F28022DAQ	40	—	—	—	12	32	Boot	9	4	—	1	9	7/325	—	1	1	1	—	—	—	3.3	20	Yes / Yes	38TSSOP
TMS320F28022PTQ	40	—	—	—	12	32	Boot	9	4	—	1	9	13/325	—	1	1	1	—	—	—	3.3	22	Yes / Yes	48LQFP
TMS320F28023DAQ	40	—	—	—	12	64	Boot	9	4	—	1	9	7/325	—	1	1	1	—	—	—	3.3	20	Yes / Yes	38TSSOP
TMS320F28023PTQ	40	—	—	—	12	64	Boot	9	4	—	1	9	13/325	—	1	1	1	—	—	—	3.3	22	Yes / Yes	48LQFP
TMS320F28026DAQ	60	—	—	—	12	32	Boot	9	4	—	1	9	7/217	—	1	1	1	—	—	—	3.3	20	Yes / Yes	38TSSOP
TMS320F28026PTQ	60	—	—	—	12	32	Boot	9	4	—	1	9	13/217	—	1	1	1	—	—	—	3.3	22	Yes / Yes	48LQFP
TMS320F28027DAQ	60	—	—	—	12	64	Boot	9	4	—	1	9	7/217	—	1	1	1	—	—	—	3.3	20	Yes / Yes	38TSSOP
TMS320F28027PTQ	60	—	—	—	12	64	Boot	9	4	—	1	9	13/217	—	1	1	1	—	—	—	3.3	22	Yes / Yes	48LQFP
TMS320F28030PAGQ	60	—	—	—	12	32	Boot	13	—	1	1	11	14/500	—	1	1	1	1	1	—	3.3	33	Yes / Yes	64TQFP
TMS320F28030PNQ	60	—	—	—	12	32	Boot	15	—	1	1	12	16/500	—	1	1	2	1	1	—	3.3	45	Yes / Yes	80LQFP
TMS320F28031PAGQ	60	—	—	—	16	64	Boot	13	—	1	1	11	14/500	—	1	1	1	1	1	—	3.3	33	Yes / Yes	64TQFP
TMS320F28031PNQ	60	—	—	—	16	64	Boot	15	—	1	1	12	16/500	—	1	1	2	1	1	—	3.3	45	Yes / Yes	80LQFP
TMS320F28032PAGQ	60	—	—	—	20	64	Boot	13	6	1	1	11	14/217	—	1	1	1	1	1	—	3.3	33	Yes / Yes	64TQFP
TMS320F28032PNQ	60	—	—	—	20	64	Boot	15	7	1	1	12	16/217	—	1	1	2	1	1	—	3.3	45	Yes / Yes	80LQFP
TMS320F28034PAGQ	60	—	—	—	20	128	Boot	13	6	1	1	11	14/217	—	1	1	1	1	1	—	3.3	33	Yes / Yes	64TQFP
TMS320F28034PNQ	60	—	—	—	20	128	Boot	15	7	1	1	12	16/217	—	1	1	2	1	1	—	3.3	45	Yes / Yes	80LQFP
TMS320F28033PAGQ	60	—	—	Yes	20	64	Boot	13	6	1	1	11	14/217	—	1	1	1	1	1	—	3.3	33	Yes / Yes	64TQFP
TMS320F28033PNQ	60	—	—	Yes	20	64	Boot	15	7	1	1	12	16/217	—	1	1	2	1	1	—	3.3	45	Yes / Yes	80LQFP
TMS320F28035PAGQ	60	—	—	Yes	20	128	Boot	13	6	1	1	11	14/217	—	1	1	1	1	1	—	3.3	33	Yes / Yes	64TQFP
TMS320F28035PNQ	60	—	—	Yes	20	128	Boot	15	7	1	1	12	16/217	—	1	1	2	1	1	—	3.3	45	Yes / Yes	80LQFP
Piccolo F2806x (Floating-Point) MCUs																								
TMS320F28069PFPQ	80	Yes	Yes	Yes	100	256	Boot	15	6	1	3	12	12/325	1	1	1	2	—	1	—	3.3	44	Yes / Yes	80HTQFP
TMS320F28069PZPQ	80	Yes	Yes	Yes	100	256	Boot	19	8	2	7	16	16/325	1	1	2	2	—	1	—	3.3	58	Yes / Yes	100HTQFP
TMS320F28068PFPQ	80	Yes	Yes	—	100	256	Boot	15	6	1	3	12	12/325	1	1	1	2	—	1	—	3.3	44	Yes / Yes	80HTQFP
TMS320F28068PZPQ	80	Yes	Yes	—	100	256	Boot	19	8	2	7	16	16/325	1	1	2	2	—	1	—	3.3	58	Yes / Yes	100HTQFP
TMS320F28067PFPQ	80	Yes	Yes	—	100	256	Boot	15	6	1	3	12	12/325	1	1	1	2	—	1	—	3.3	44	Yes / Yes	80HTQFP
TMS320F28067PZPQ	80	Yes	Yes	—	100	256	Boot	19	8	2	7	16	16/325	1	1	2	2	—	1	—	3.3	58	Yes / Yes	100HTQFP
TMS320F28066PFPQ	80	—	Yes	—	68	256	Boot	15	6	1	3	12	12/325	1	1	1	2	—	1	—	3.3	44	Yes / Yes	80HTQFP
TMS320F28066PZPQ	80	—	Yes	—	68	256	Boot	19	8	2	7	16	16/325	1	1	2	2	—	1	—	3.3	58	Yes / Yes	100HTQFP
TMS320F28065PFPQ	80	Yes	Yes	Yes	100	128	Boot	15	6	1	3	12	12/325	1	1	1	2	—	1	—	3.3	44	Yes / Yes	80HTQFP
TMS320F28065PZPQ	80	Yes	Yes	Yes	100	128	Boot	19	8	2	7	16	16/325	1	1	2	2	—	1	—	3.3	58	Yes / Yes	100HTQFP
TMS320F28064PFPQ	80	Yes	Yes	—	100	128	Boot	15	6	1	3	12	12/325	1	1	1	2	—	1	—	3.3	44	Yes / Yes	80HTQFP
TMS320F28064PZPQ	80	Yes	Yes	—	100	128	Boot	19	8	2	7	16	16/325	1	1	2	2	—	1	—	3.3	58	Yes / Yes	100HTQFP
TMS320F28063PFPQ	80	Yes	Yes	—	68	128	Boot	15	6	1	3	12	12/325	1	1	1	2	—	1	—	3.3	44	Yes / Yes	80HTQFP
TMS320F28063PZPQ	80	Yes	Yes	—	68	128	Boot	19	8	2	7	16	16/325	1	1	2	2	—	1	—	3.3	58	Yes / Yes	100HTQFP
TMS320F28062PFPQ	80	—	Yes	—	36	128	Boot	15	6	1	3	12	12/325	1	1	1	2	—	1	—	3.3	44	Yes / Yes	80HTQFP
TMS320F28062PZPQ	80	—	Yes	—	36	128	Boot	19	8	2	7	16	16/325	1	1	2	2	—	1	—	3.3	58	Yes / Yes	100HTQFP

Isolation, Analog and Power Management Products

Introduction to TI Isolation Products

The problem

- **No endurance** – existing isolation devices have a life expectancy of only seven to 10 years
- **No high speed or precision** – existing isolation devices – low speed, high skew, high jitter and high pulse distortion
- **No high temp** – existing isolation devices cannot operate at 150 Mbps at 125°C. Only a few can operate at >100°C at any speed
- **Low EMI immunity** – existing high-speed isolators are susceptible to EMI interference

The solution

- The TI integrated SiO₂ isolation barrier technology provides the fastest, highest precision, highest temperature, high EMI immunity and longest life solution

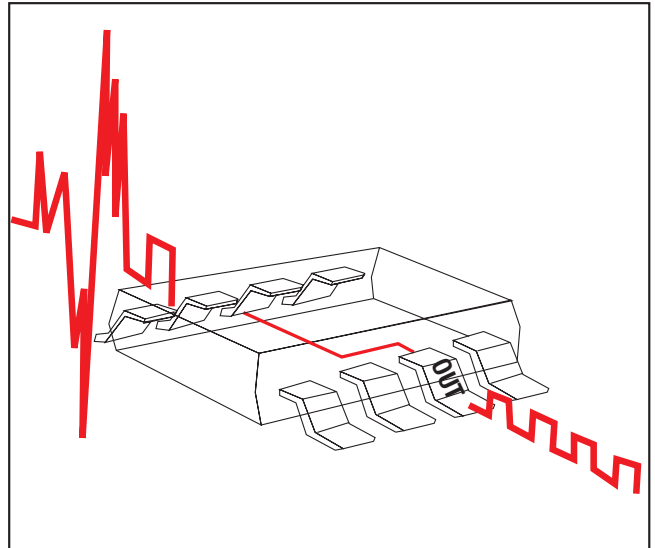

Isolation, Analog and Power Management Products

TI Isolated Products

ISO722X Dual-Channel, 25-Mbps Digital Isolator

The ISO7220 and ISO7221 are dual-channel digital isolators. To facilitate PCB layout, the channels are oriented in the same direction in the ISO7220 and in opposite directions in the ISO7221. These devices have a logic input and output buffer separated by TI's silicon-dioxide (SiO₂) isolation barrier, providing galvanic isolation of up to 4,000 V. Used in conjunction with isolated power supplies, these devices block high voltage, isolate grounds and prevent noise currents on a data bus or other circuits from entering the local ground and interfering with or damaging sensitive circuitry.

A binary input signal is conditioned, translated to a balanced signal, then differentiated by the capacitive isolation barrier. Across the isolation barrier, a differential comparator receives the logic transition information, then sets or resets a flip-flop and the output circuit accordingly. A periodic update pulse is sent across the barrier to ensure the proper DC level of the output. If this DC refresh pulse is not received every 4 μs, the input is assumed to be unpowered or not being actively driven, and the failsafe circuit drives the output to a logic high state.

The small capacitance and resulting time constant provide fast operation, with signaling rates available from 0 Mbps (DC) to 25 Mbps. The signaling rate of a line is the number of voltage transitions that are made per second expressed in the unit's BPS (bits per second). The A-option and C-option devices have TTL input thresholds and a noise filter at the input that prevents transient pulses from being passed to the output of the device.

These devices require two supply voltages of 3.3 V, 5 V or any combination. All inputs are 5-V tolerant when supplied from a 3.3-V supply and all outputs are 4-mA CMOS.

Key Features

- Qualified for automotive applications
- 1-Mbps and 25-Mbps signaling rate options
- Low channel-to-channel output skew 1 ns max
- Low pulse-width distortion (PWD) 1 ns max
- Low jitter content: 1 ns typical at 150 Mbps
- 25-year typical life at rated voltage (see application report SLLA197 and Figure 14)
- 4,000-VPEAK isolation, 560-VPEAK VIORM
- UL 1577, IEC 60747-5-2 (VDE 0884, Rev 2), IEC 61010-1, IEC 60950-1 and CSA approved
- 50-kV/μs typical transient immunity
- Operates with 3.3-V or 5-V supplies
- 4-kV ESD protection
- High electromagnetic immunity
- 40°C to 125°C operating free-air temperature range

Single-Channel Functional Diagram

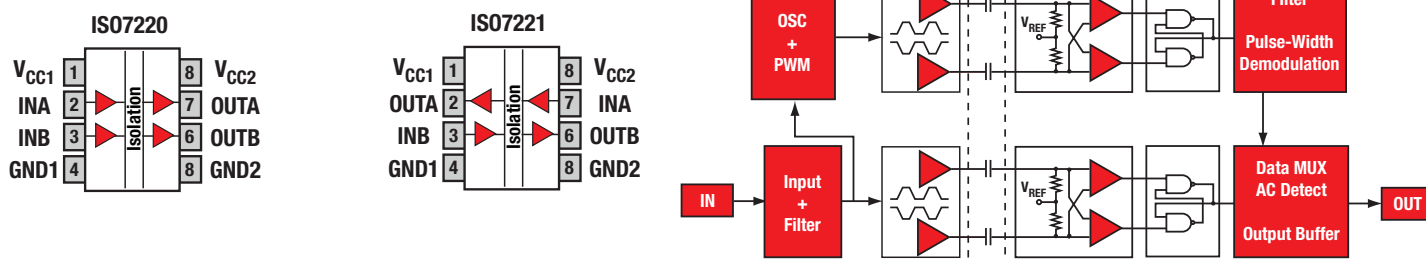

Digital Isolator Selection Guide

Device	No. of Channels	Channel Configuration	Insulation Rating (V _{RMS})	Supply Voltage (V)	Data Rate (Mbps)	ESD (kV)	Operating Temp Range (°C)	Package	Auto Qual (Q1)
ISO721-Q1	1	1/0	2,500	3.3, 5.0	100	4	-40 to 125	8/SO	Y
ISO722x-Q1	2	2/0, 1/1	2,500	3.3, 5.0	1, 5, 25	4	-40 to 125	8/SO	Y
ISO724x-Q1	4	4/0, 3/1, 2/2	2,500	3.3, 5.0	1, 25	4	-40 to 125	16/SO	Y
ISO7421A/E-Q1	2	2/0, 1/1	2,500	3.3, 5.0	1	4	-40 to 125	8/SO	Y

Learn more at: www.ti.com/ISO7221Cxx

Isolation, Analog and Power Management Products

TI Isolated Products

SN6501 Transformer Driver for Isolated Power Supplies

The SN6501 is a monolithic oscillator/power-driver, specifically designed for small form factor, isolated power supplies in isolated interface applications. It drives a low-profile, center-tapped transformer primary from a 3.3 V or 5 V DC power supply. The secondary can be wound to provide any isolated voltage based on transformer turns ratio.

The SN6501 consists of an oscillator followed by a gate drive circuit that provides the complementary output signals to drive the ground referenced N-channel power switches. The internal logic ensures break-before-make action between the two switches.

The SN6501 is available in a small SOT23-5 package, and is specified for operation at temperatures from -40°C to 125°C .

Key features

- Push-Pull Driver for Small Transformers
- Single 3.3 V or 5 V Supply
- High Primary-side Current Drive:
 - 5 V Supply: 350 mA (max)
 - 3.3 V Supply: 150 mA (max)
- Low Ripple on Rectified Output Permits Small Output Capacitors
- Small 5-pin SOT23 Package

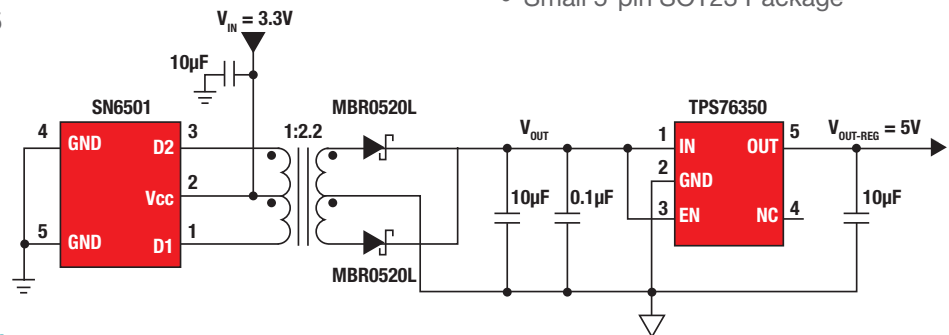

Learn more at: www.ti.com/product/sn6501

AMC1204-Q1 1-Bit, 20 MHz, Second-Order, Isolated Delta-Sigma Modulator

The AMC1204-Q1 is a 1-bit digital output, isolated delta-sigma ($\Delta\Sigma$) modulators that can be clocked at up to 20 MHz. The digital isolation of the modulator output is provided by a silicon dioxide (SiO_2) barrier that is highly resistant to magnetic interference. This barrier has been certified to provide basic galvanic isolation of up to 4250 VPEAK according to UL1577, IEC60747-5-2, and CSA standards or specifications.

The AMC1204-Q1 provides a single-chip solution for measuring the small signal of a shunt resistor across an isolated barrier. These types of resistors are typically used to sense currents in motor control inverters, green energy generation systems, and other industrial applications. The AMC1204-Q1 differential inputs easily connect to the shunt resistor or other low-level signal sources. An internal reference eliminates the need for external components. When used with an appropriate external digital filter, an effective number of bits (ENOB) of 14 is achieved at a data rate of 78 kSPS.

Key features

- AEC-Q100 qualified with the following results
 - Device temperature grade 1: -40°C to 125°C ambient operating temperature range
 - Device HBM ESD classification level H2
 - Device CDM ESD classification level C3B
- $\pm 250\text{-mV}$ input voltage range optimized for shunt resistors
- Certified digital isolation
- Long isolation barrier lifetime (see application report SLLA197)
- High electromagnetic field immunity
- Outstanding AC performance
- Excellent DC precision
- External clock input for easier synchronization
- Fully specified over the extended automotive temperature range

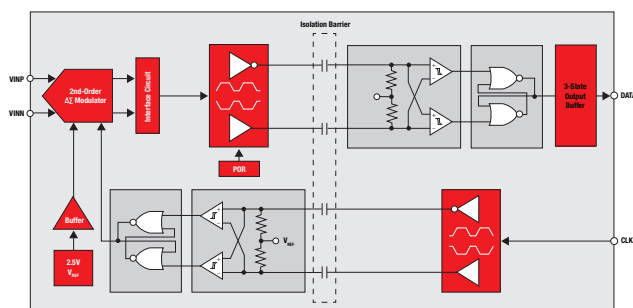

Learn more at: www.ti.com/AMC1204

Isolation, Analog and Power Management Products

TI Isolated Products

Device	Description	AEC-Q100 status
Automotive signal chain		
INA19xA-Q1	-16-V to 80-V common-mode-range current shunt monitors	Qualified
INA213A-Q1	Voltage output, bidirectional zero-drift series current shunt monitor	Qualified
OPA365-Q1	2.2-V, 50-MHz, low-noise, single-supply rail-to-rail operational amplifiers	Qualified
TLV3502-Q1	4.5-ns rail-to-rail high-speed comparator	Qualified
LM2902/4-Q1	Operational amplifier	Qualified
LM2901/3-Q1	Differential comparator	Qualified
TL4050yxx-Q1	Precision micropower shunt voltage reference	Qualified
TPS380xx-Q1	Supply voltage supervisors	Qualified
INA282-Q1	Wide common-mode range, bidirectional, high-accuracy current shunt monitor	Qualified
AMC1204-Q1	Isolated ADC	Qualified
AMC1200-Q1	Isolated ADC	Qualified
INA148-Q1	+/-200V common-mode voltage difference amplifier	Qualified
INA20x-Q1	Current shunt monitor with comparator and reference / dual comparators	Qualified
INA16x-Q1	Current shunt monitor with comparator, current output	Qualified
INA27x-Q1	Voltage output current shunt monitor	Qualified
INA214-Q1	Voltage Output, High/Low-Side Measurement, Bi-Directional Zero-Drift Series	Qualified
ADS7841-Q1	Automotive Catalog 12-Bit, 4-Channel Serial Output Sampling Analog-to-Digital Converter	Qualified
Automotive power management – DC/DC converter, LDO		
AMC1204-Q1	1-Bit, 20 MHz, second-order, isolated delta-sigma modulator	Qualified
TPS54x0-Q1	1-A/2-A/3-A/5-A wide-input-range step-down SWIFT™ converter	Qualified
TPS54x62-Q1	Low Iq 3-A step-down converter	Qualified
TPS54240-Q1	2.5A, 4.5-42 VIN DC-DC convert in 3mmx3mm SON package	Preview
TPS54540/560/-Q1	5.5A, 4.7-42/60 VIN Buck Converter with low drop out operation	Preview
TPS54061/3-Q1	200-mA/800-mA 4.7-60 VIN Synchronous Buck Converter	Qualified, Preview
TPS54340/360-Q1	3.5A, 4.7-42/60 VIN buck converter with low drop out operation	Preview
TPS40090-Q1-Q1	2-, 3-, or 4-phase programmable synchronous buck controller optimized for low-voltage, high-current application	Qualified
TPS40170-Q1	4.5 V to 60 V Wide-Input Synchronous PWM Buck Controller	Qualified
TPS55340-Q1	Integrated 5-A 40V Boost / SEPIC / Flyback Regulator	Preview
TPS57x60-Q1	3.5-V to 60-V, 0.5A and 1.5-A step-down SWIFT converter with Eco-mode™ control scheme	Qualified
TPS7A16xx-Q1	60V, 5-µA Iq, 100-mA, Low-Dropout Voltage Regulator with Enable and Power Good	Qualified
TPS7A6xx-Q1	40-V, 300-mA, Low-Dropout Regulator With Ultra-Low Quiescent Current	Qualified
TPS7A6950-Q1	150mA, High Voltage, Ultra Low Iq (20uA), Low Drop Out Regulator in SOIC Package	Qualified
TPS7A6650-Q1	150mA, High Voltage, Ultra Low Iq (20uA), Low Drop Out Regulator in MSOP Package	Qualified
LM5010AQ0	75V 1A, 1MHz buck converter with internal compensation (Tj 150C)	Qualified
LM25011Q	42V, 2A Constant On-Time buck converter with Adjustable Current Limit	Qualified
LM5117Q	65V Synchronous buck controller with current monitor	Qualified
LM5118Q	75V buck-boost controller with 10uA max shutdown current	Qualified
LM5119Q	65V Dual or interleaved synchronous buck controller with programmable current limit	Preview
LM5122Q	65V Synchronous boost controller with multiphase capability	Preview
Automotive power management – PWM controller		
UCC28950-Q1	Green Phase-Shifted Full-Bridge Controller with Synchronous Rectification	Qualified
UC2856-Q1	Improved current-mode PWM controller	Qualified
UC2825A-Q1	High-speed PWM controller	Qualified
UC2843-Q1	Current-mode PWM controller	Qualified
UCC2813-Q1	Low-power BiCMOS current-mode PWM	Qualified
TPS40210-Q1-Q1	Wide-input-range current-mode boost controller	Qualified
UCC280x-Q1	Automotive catalog low-power BiCMOS current-mode PWM	Qualified
UCC28220-Q1	Dual interleaved PWM controller with programmable max duty cycle	Qualified
UCC2808A-2-Q1	Low-power current-mode push-pull PWM	Qualified
UCC2895-Q10-Q1	Green Phase-Shifted Full-Bridge Controller with Synchronous Rectification	Qualified

Texas Instruments offers a wide range of devices specifically fitted for use in the HEV/EV space. Please check www.ti.com for the latest device announcements.

Isolation, Analog and Power Management Products

TI Isolated Products

Device	Description	AEC-Q100 status
Automotive Protection Devices		
LM5060Q1	High-Side Protection Controller with Low Quiescent Current	Qualified
LM5050Q1	Wide-Input-Range Ideal Diode Controller	Preview
Automotive gate driver		
TPS2811-Q1	Dual high-speed MOSFET drivers	Qualified
TPS28x9-Q1	High-speed MOSFET driver	Qualified
UCC27200/1-Q1	120-V boot, 3-A peak, high-frequency, high-side/low-side driver	Qualified
UCC27423/4/5-Q1	Dual 4-A high-speed low-side MOSFET drivers with enable	Qualified
UCC27321/2/4-Q1	Single 9-A peak high-speed low-side power MOSFET drivers	Qualified
Automotive digital isolators		
SN6501-Q1	Transformer driver for Isolated Power supplies	Preview
ISO721-Q1	Single 100-Mbps digital isolator	Qualified
ISO7221C-Q1	Dual-channel, 25-Mbps digital isolator	Qualified
ISO7240CF/1C-Q1	Quad-channel, 25-Mbps digital isolator	Qualified
ISO7220A/1A-Q1	Dual-channel, 1-Mbps digital isolator	Qualified
ISO7421E-Q1	Automotive Catalog Low-Power Dual Channel Digital Isolators	Qualified
ISO7231C-Q1	Automotive Catalog Triple Channel, 2/1, 25Mbps, Digital Isolator	Qualified
Automotive CAN interface		
SN65HVDA1050A-Q1	EMC-optimized high-speed CAN transceiver	Qualified
SN65HVDA1040A-Q1	EMC-optimized high-speed CAN transceiver	Qualified
SN65HVDA540-Q1	CAN transceiver 5-V to 3.3-V MCU interface	Qualified
SN65HVDA541-Q1	CAN transceiver 5-V to 3.3-V MCU interface, wakeup	Qualified
Automotive Logic		
SN74AVCXT245-Q1	Dual-Supply Bus Transceiver w/ Configurable Voltage Translation, Low Power Consumption	Qualified
SN74LVCxT45-Q1	Dual Supply Transceiver with Configurable Voltage Translation	Qualified
SN74HC244-Q1	Octal Buffers And Line Drivers With 3-State Outputs	Qualified
SN74HC08-Q1	Quadruple 2-Input Positive-AND Gates	Qualified
SN74HC00-Q1	Quadruple 2-Input Positive-NAND Gates	Qualified
SN74HC14-Q1	Hex Schmitt-Trigger Inverters	Qualified
SN74HC04-Q1	Hex Inverters	Qualified

Texas Instruments offers a wide range of devices specifically fitted for use in the HEV/EV space. Please check www.ti.com for the latest device announcements.

WEBENCH® Design Center

Get results faster with easy-to-use design tools that deliver custom results.



Quickly compare performance across multiple parameters for complete systems

- Designer Series—
Single-circuit design tools
- Architect Series—
Advanced hierarchical design tools
- Unique Design Features—
Visualizer and Optimizer Dial

www.ti.com/webench



TI Worldwide Technical Support

Internet

TI Semiconductor Product Information Center Home Page
support.ti.com

TI E2E™ Community Home Page
e2e.ti.com

Product Information Centers

Americas	Phone	+1(512) 434-1560
Brazil	Phone	0800-891-2616
Mexico	Phone	0800-670-7544
	Fax	+1(972) 927-6377
	Internet/Email	support.ti.com/sc/pic/americas.htm

Europe, Middle East, and Africa

Phone		
European Free Call	00800-ASK-TEXAS (00800 275 83927)	
International	+49 (0) 8161 80 2121	
Russian Support	+7 (4) 95 98 10 701	

Note: The European Free Call (Toll Free) number is not active in all countries. If you have technical difficulty calling the free call number, please use the international number above.

Fax	+ (49) (0) 8161 80 2045
Internet	www.ti.com/asktexas
Direct Email	asktexas@ti.com

Japan

Phone	Domestic	0120-92-3326
Fax	International	+81-3-3344-5317
	Domestic	0120-81-0036
Internet/Email	International	support.ti.com/sc/pic/japan.htm
	Domestic	www.tij.co.jp/pic

Asia

Phone		
International	+91-80-41381665	
Domestic	<u>Toll-Free Number</u>	
Note: Toll-free numbers do not support mobile and IP phones.		
Australia	1-800-999-084	
China	800-820-8682	
Hong Kong	800-96-5941	
India	1-800-425-7888	
Indonesia	001-803-8861-1006	
Korea	080-551-2804	
Malaysia	1-800-80-3973	
New Zealand	0800-446-934	
Philippines	1-800-765-7404	
Singapore	800-886-1028	
Taiwan	0800-006800	
Thailand	001-800-886-0010	
Fax	+8621-23073686	
Email	tiasia@ti.com or ti-china@ti.com	
Internet	support.ti.com/sc/pic/asia.htm	

Important Notice: The products and services of Texas Instruments Incorporated and its subsidiaries described herein are sold subject to TI's standard terms and conditions of sale. Customers are advised to obtain the most current and complete information about TI products and services before placing orders. TI assumes no liability for applications assistance, customer's applications or product designs, software performance, or infringement of patents. The publication of information regarding any other company's products or services does not constitute TI's approval, warranty or endorsement thereof.

B090712

The platform bar, E2E, C2000, C28x, Code Composer Studio, controlCARD, ControlSuite, Eco-mode, MSP430, Predictive Gate Drive, Piccolo, PowerPAD, PowerPump, PowerTrain and SWIFT are trademarks of Texas Instruments. All other trademarks are the property of their respective owners.

IMPORTANT NOTICE

Texas Instruments Incorporated and its subsidiaries (TI) reserve the right to make corrections, enhancements, improvements and other changes to its semiconductor products and services per JESD46, latest issue, and to discontinue any product or service per JESD48, latest issue. Buyers should obtain the latest relevant information before placing orders and should verify that such information is current and complete. All semiconductor products (also referred to herein as "components") are sold subject to TI's terms and conditions of sale supplied at the time of order acknowledgment.

TI warrants performance of its components to the specifications applicable at the time of sale, in accordance with the warranty in TI's terms and conditions of sale of semiconductor products. Testing and other quality control techniques are used to the extent TI deems necessary to support this warranty. Except where mandated by applicable law, testing of all parameters of each component is not necessarily performed.

TI assumes no liability for applications assistance or the design of Buyers' products. Buyers are responsible for their products and applications using TI components. To minimize the risks associated with Buyers' products and applications, Buyers should provide adequate design and operating safeguards.

TI does not warrant or represent that any license, either express or implied, is granted under any patent right, copyright, mask work right, or other intellectual property right relating to any combination, machine, or process in which TI components or services are used. Information published by TI regarding third-party products or services does not constitute a license to use such products or services or a warranty or endorsement thereof. Use of such information may require a license from a third party under the patents or other intellectual property of the third party, or a license from TI under the patents or other intellectual property of TI.

Reproduction of significant portions of TI information in TI data books or data sheets is permissible only if reproduction is without alteration and is accompanied by all associated warranties, conditions, limitations, and notices. TI is not responsible or liable for such altered documentation. Information of third parties may be subject to additional restrictions.

Resale of TI components or services with statements different from or beyond the parameters stated by TI for that component or service voids all express and any implied warranties for the associated TI component or service and is an unfair and deceptive business practice. TI is not responsible or liable for any such statements.

Buyer acknowledges and agrees that it is solely responsible for compliance with all legal, regulatory and safety-related requirements concerning its products, and any use of TI components in its applications, notwithstanding any applications-related information or support that may be provided by TI. Buyer represents and agrees that it has all the necessary expertise to create and implement safeguards which anticipate dangerous consequences of failures, monitor failures and their consequences, lessen the likelihood of failures that might cause harm and take appropriate remedial actions. Buyer will fully indemnify TI and its representatives against any damages arising out of the use of any TI components in safety-critical applications.

In some cases, TI components may be promoted specifically to facilitate safety-related applications. With such components, TI's goal is to help enable customers to design and create their own end-product solutions that meet applicable functional safety standards and requirements. Nonetheless, such components are subject to these terms.

No TI components are authorized for use in FDA Class III (or similar life-critical medical equipment) unless authorized officers of the parties have executed a special agreement specifically governing such use.

Only those TI components which TI has specifically designated as military grade or "enhanced plastic" are designed and intended for use in military/aerospace applications or environments. Buyer acknowledges and agrees that any military or aerospace use of TI components which have **not** been so designated is solely at the Buyer's risk, and that Buyer is solely responsible for compliance with all legal and regulatory requirements in connection with such use.

TI has specifically designated certain components as meeting ISO/TS16949 requirements, mainly for automotive use. In any case of use of non-designated products, TI will not be responsible for any failure to meet ISO/TS16949.

Products

Audio	www.ti.com/audio
Amplifiers	amplifier.ti.com
Data Converters	dataconverter.ti.com
DLP® Products	www.dlp.com
DSP	dsp.ti.com
Clocks and Timers	www.ti.com/clocks
Interface	interface.ti.com
Logic	logic.ti.com
Power Mgmt	power.ti.com
Microcontrollers	microcontroller.ti.com
RFID	www.ti-rfid.com
OMAP Applications Processors	www.ti.com/omap
Wireless Connectivity	www.ti.com/wirelessconnectivity

Applications

Automotive and Transportation	www.ti.com/automotive
Communications and Telecom	www.ti.com/communications
Computers and Peripherals	www.ti.com/computers
Consumer Electronics	www.ti.com/consumer-apps
Energy and Lighting	www.ti.com/energy
Industrial	www.ti.com/industrial
Medical	www.ti.com/medical
Security	www.ti.com/security
Space, Avionics and Defense	www.ti.com/space-avionics-defense
Video and Imaging	www.ti.com/video

TI E2E Community

e2e.ti.com