

Générateur électrique continu

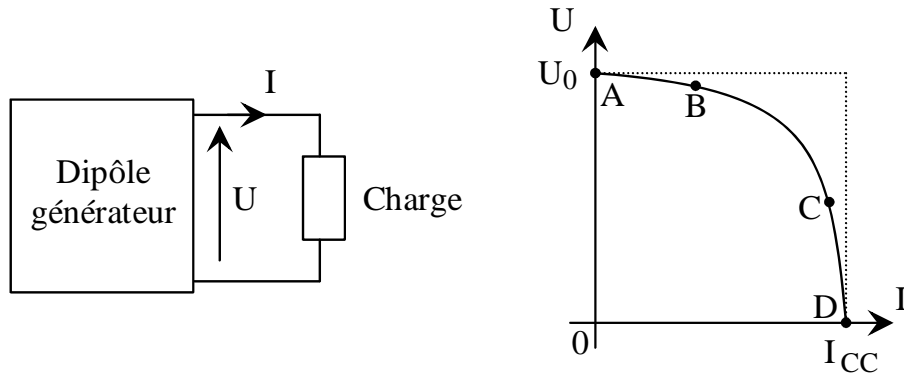

Source de tension :

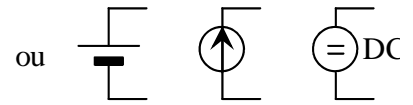
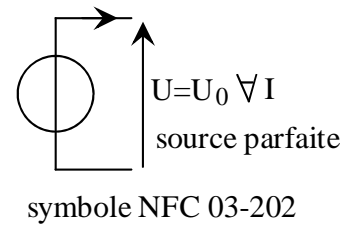
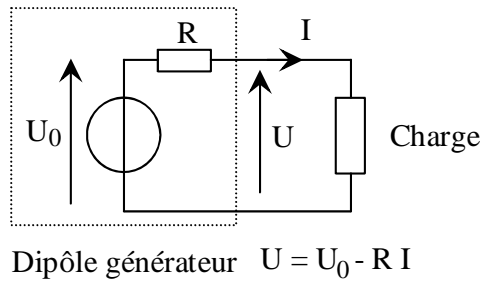

Source de courant :

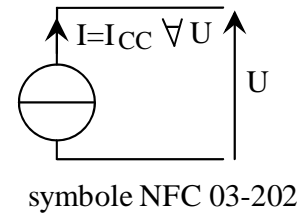
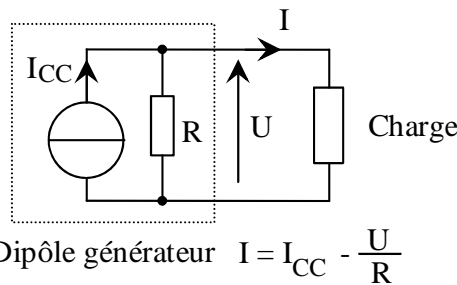

Générateur électrique alternatif

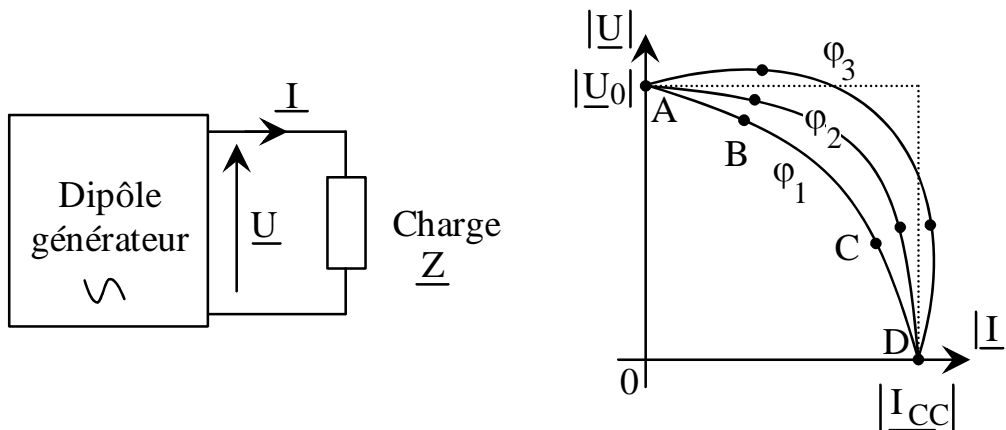

Confirmation de la nature de la source

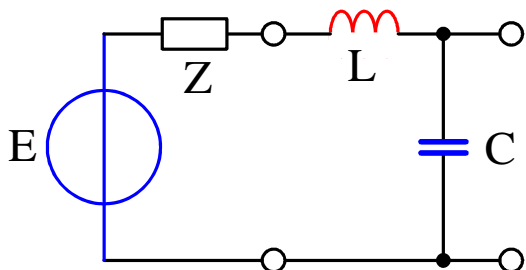

a) Source de tension

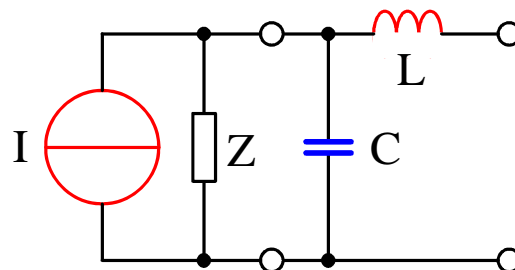

b) Source de courant

Changement de la nature de la source

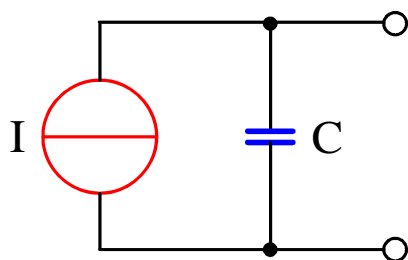

a) Source de tension

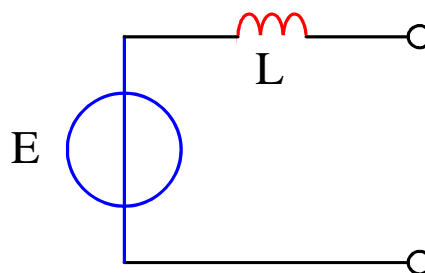

b) Source de courant

Natures et réversibilités des sources

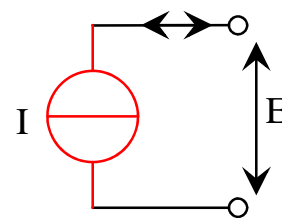
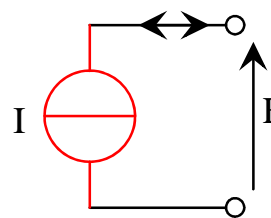
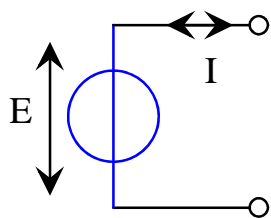
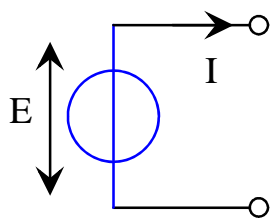
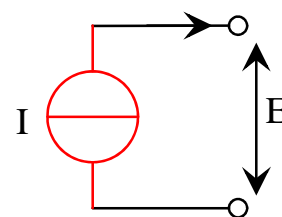
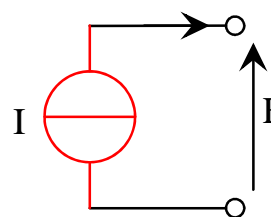
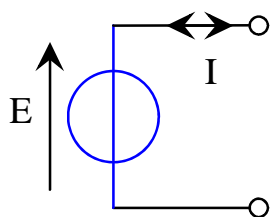
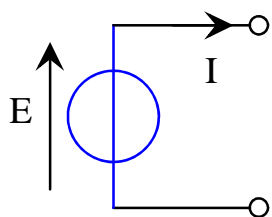

Source de tension

Source de courant

Association et utilisations des sources

☞ Ne pas court-circuiter une source de tension.

☞ Ne pas ouvrir une source de courant.

💣 **Ne pas connecter directement entre-elles des sources de même nature ...**

☞ ... sauf si les grandeurs électriques sont identiques !

Configurations possibles connectant des sources de nature différentes

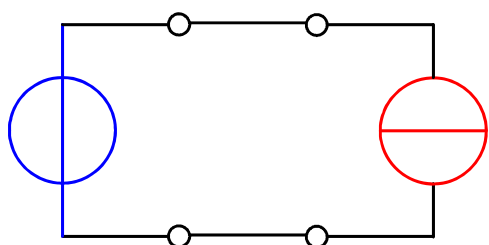

a) phase active directe

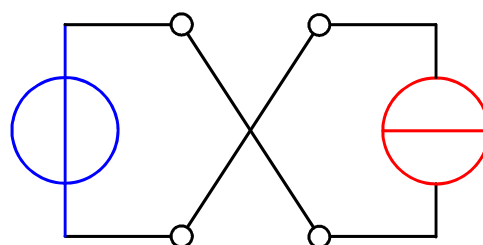

b) connexion indirecte

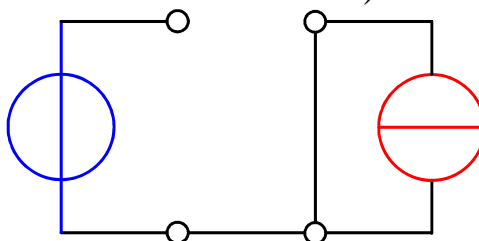

c) roue libre

Structure générale d'un convertisseur direct

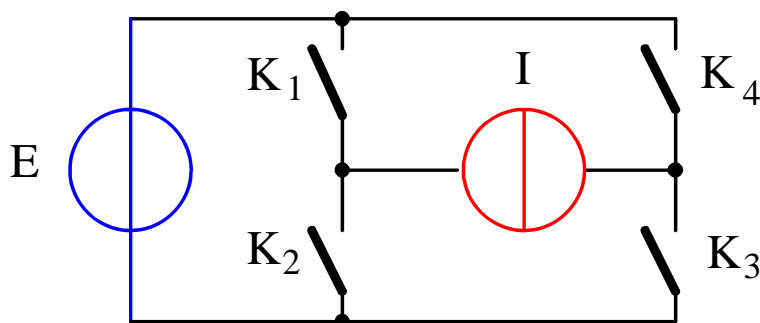

Configurations	Inter. ouverts	Inter. fermés
a) transfert direct	K1 et K3	K2 et K4
b) transfert indirect	K2 et K4	K1 et K3
c) roue libre	(K2 et K3) ou (K1 et K4)	(K1 et K4) ou (K2 et K3)

Exemple (U ; U) : stockage inductif

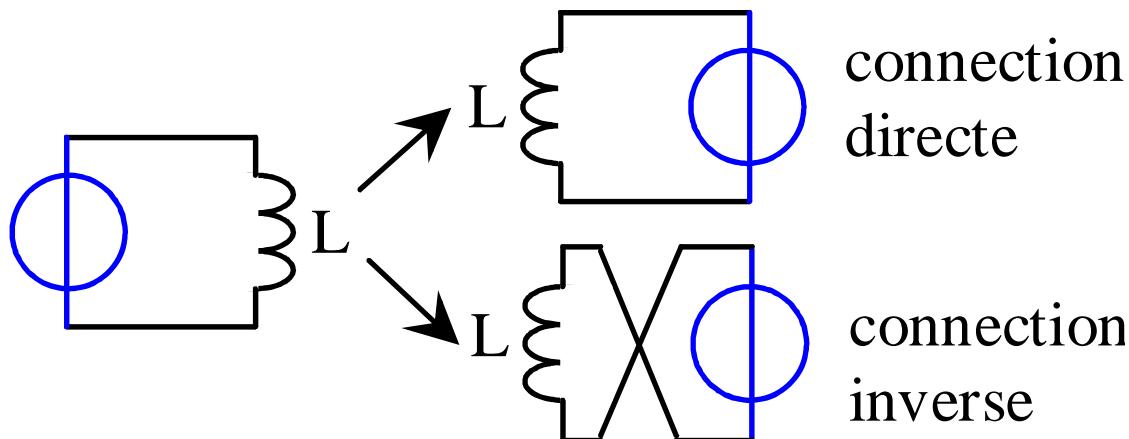

Structure générale d'un convertisseur indirect

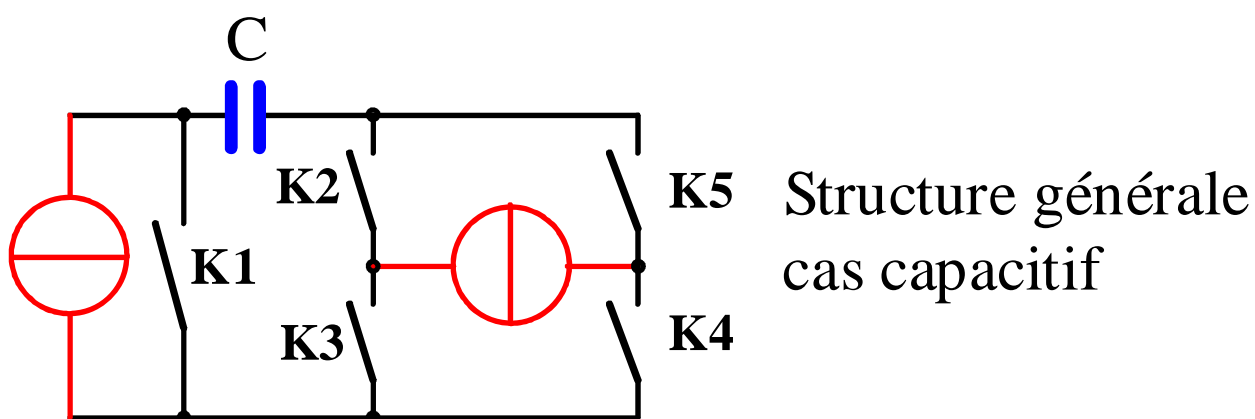
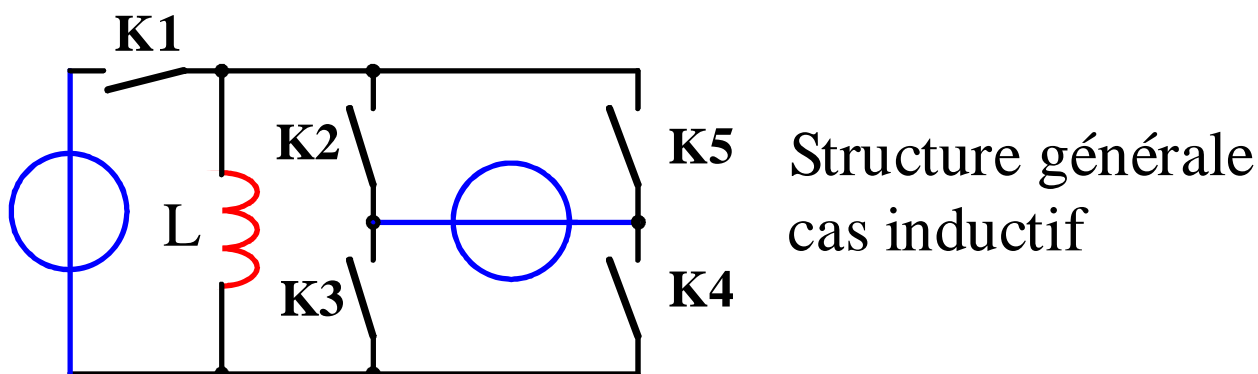

Caractéristiques statiques de l'interrupteur

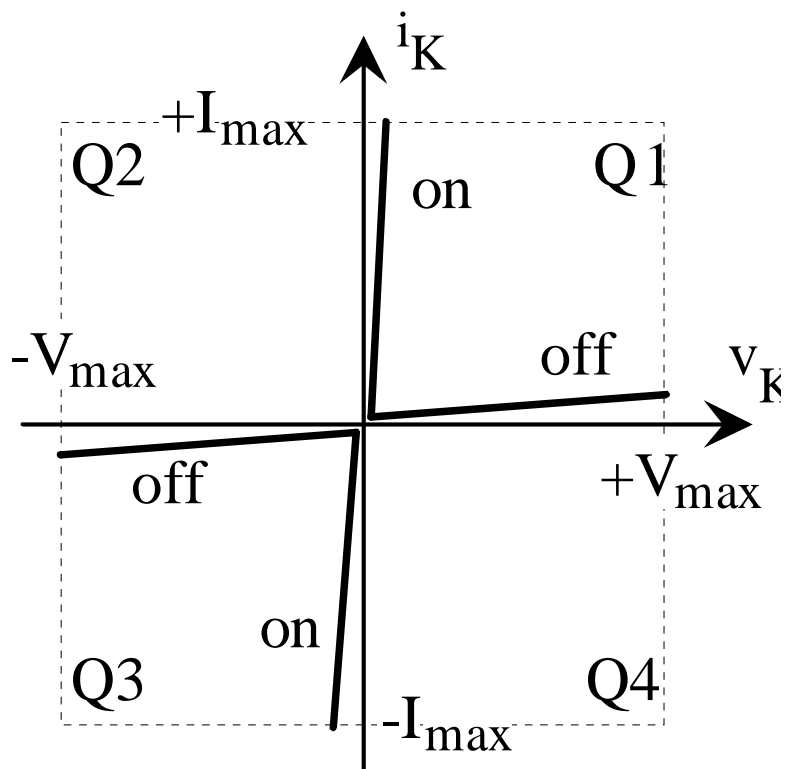

Caractéristiques à deux segments

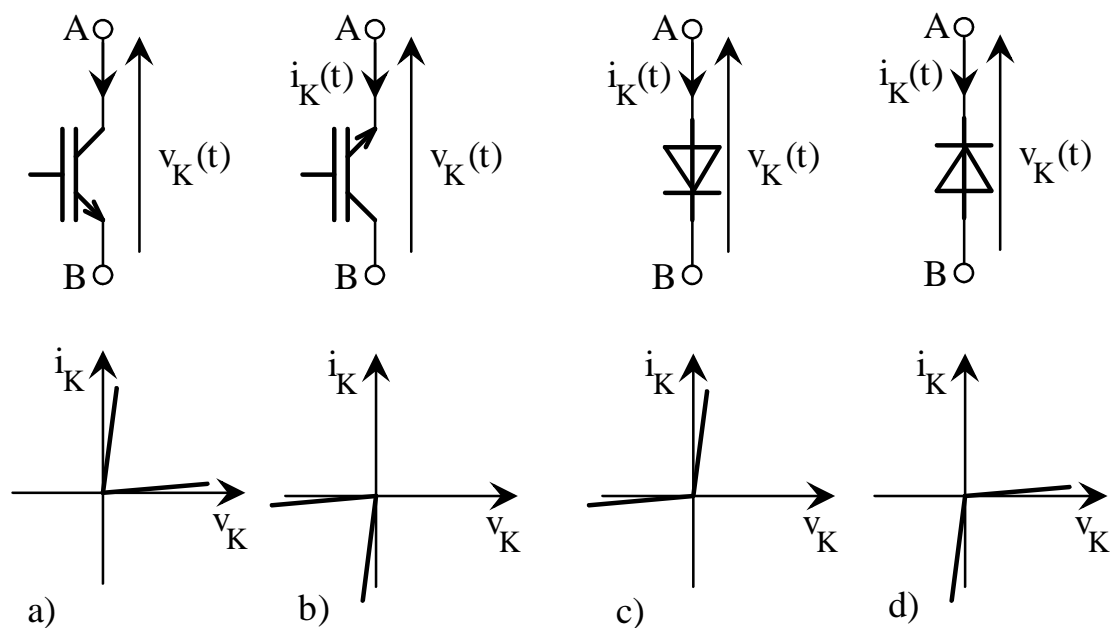

Caractéristiques à trois segments

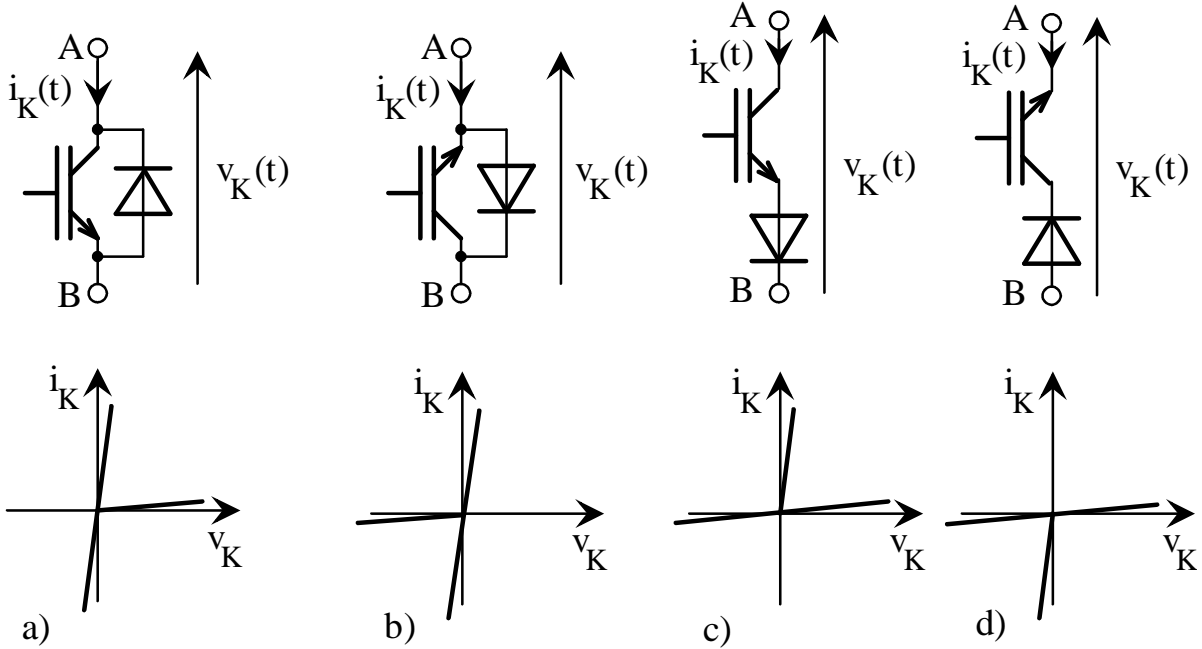

Synthèse d'interrupteur à 3 segments

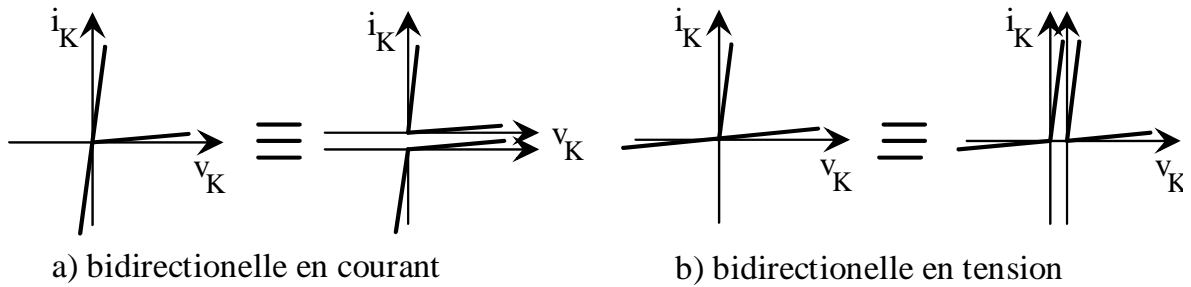

Caractéristiques à quatre segments

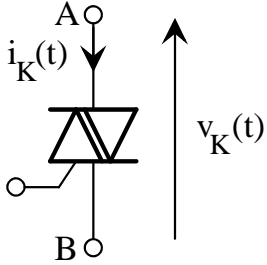

a) le triac

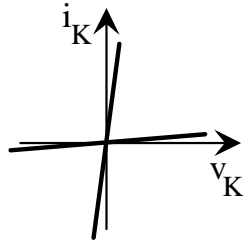

b) caractéristiques

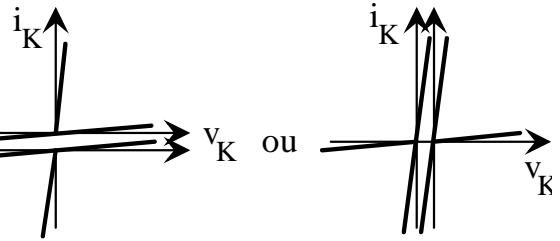

c) synthèses

Synthèse d'interrupteur à 4 segments

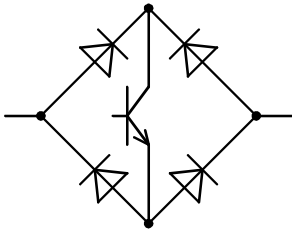

(a)

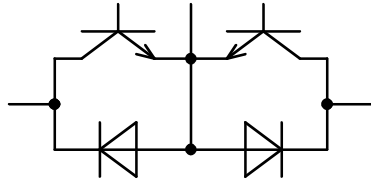

(b)

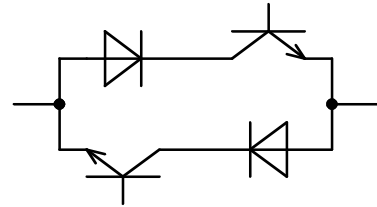

(c)

Changements d'états

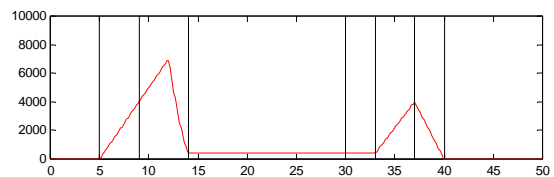
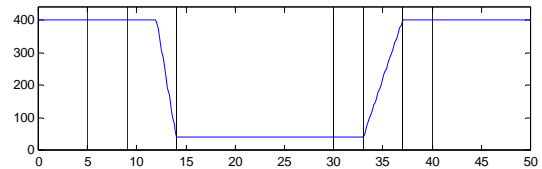
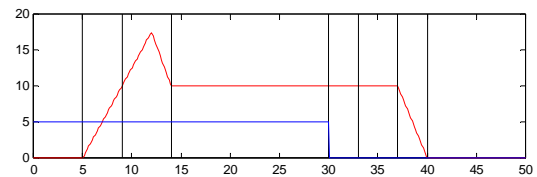
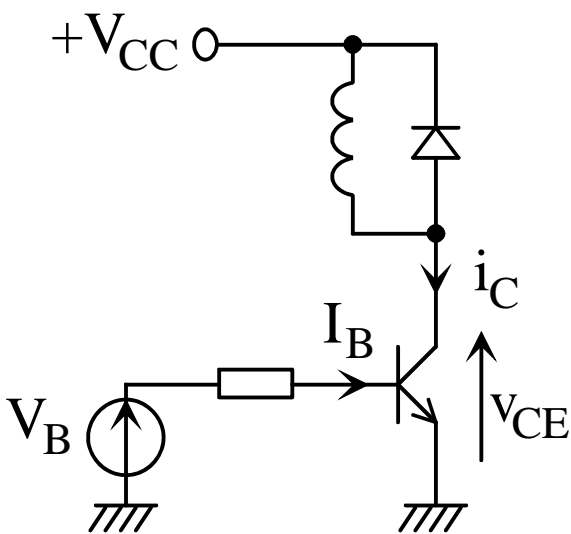

Commutations de l'interrupteur

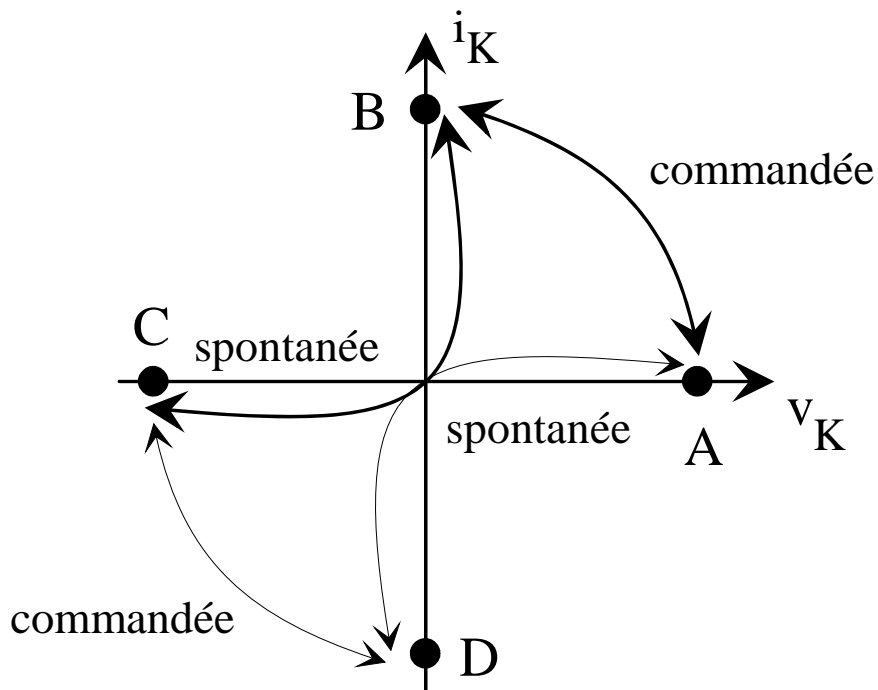

Classification des interrupteurs

	Amorçage spontané	Amorçage commandé
Blocage spontané	<p>Diode</p>	<p>Thyristor</p>
Blocage commandé	<p>Thyristor-dual</p>	<p>Transistor</p>