

11.3 H2Q version B2 - Hacheur 2 quadrants 60V/10A

Projet : IUT3

Info : [DIV414]

Révision : H2Qb – rev. 2 du 4 février 2014

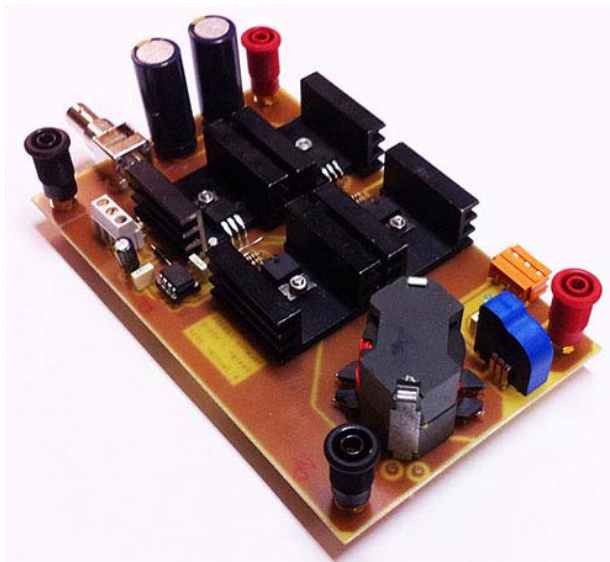

Fig. 11.10. Maquette H2Qb (images-maquettes\ H2Q-B2-13.jpg).

11.3.1 Désignation des composants H2Qb2

Tableau 11.3. Liste de composants (projets-iut3.xls / H2Qb2).

N°	Quantité	Référence	Désignation	Empreinte
1	2	B1,B3	HEADER 1	EMBASE
2	1	B2	OUT	EMBASE
3	1	B4	MASSE	EMBASE
4	2	C4,C1	330uF 100V	RADIAL16
5	3	C2,C7,C8	100nF	CK06
6	1	C5	120uF 25V	RADIAL06L
7	1	C6	10uF 25V	RADIAL06L
8	2	D1,D2	MBR20100CTP	TO220-KL224-38
9	1	D3	BYV95A	DO41
10	1	JP1	COURANT	03PL2
11	1	JP3	CDE	03PL2
12	1	JP4	CDE	BNC1
13	1	LEM1	LTS25-NP	LTS25
14	1	L1	500uH 10A	RM14
15	2	Q1,Q2	IRF540N	TO220-KL224-38
16	2	R1,R3	75	RC04
17	2	R2,R4	1k	RC04
18	1	R6	4.7k	RC02
19	1	U1	IR2111	08DIP300L

11.3.2 Chronogrammes H2Qb – RM14 – réalisation étudiants

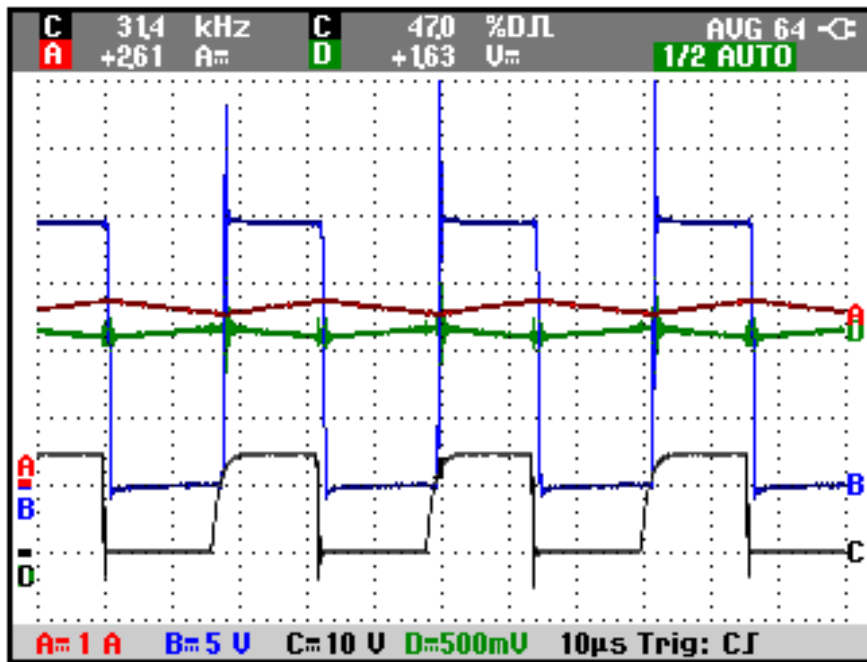

Fig. 11.11. Courant de l'inductance et tension de sortie du capteur de courant (2014-02-06-Mesures\2014-02-07-H2Q-B-1.bmp).

Essais en hacheur de type BUCK avec capteur LEM LTS 6-NP – 3 tours

Ve =	20	30	V
F =	31 400	31 401	Hz
Alpha =	0,506	0,506	
I _{max} =	2,87	6,42	A
I _{min} =	2,67	5,74	A
DIL =	0,2	0,68	A
L =	0,000796064	0,000351193	H
L =	796,06	351,19	µH
D =	1,570	0,503	V
pour 0A =	2,500	2,500	V
dV _{Imes} =	0,930	1,997	V
I _{moy} =	2,77	6,05	A
DIV _{calculé} =	0,866	1,891	V
F0 =	3140		Hz
LC =	2,5691E-09		
L(µh) = / C(µF)			
=	100	25,691	
L(µh) = / C(µF)			
=	47	54,662	
L(µh) = / C(µF)			
=	10	256,910	

Ondulation du courant du hacheur de type Buck $\Delta I_L = \frac{V_e}{L \times F} \times \alpha \times (1 - \alpha)$

Inductance $L = \frac{V_e}{\Delta I_L \times F} \times \alpha \times (1 - \alpha) = 796 / 351 \mu\text{H}$: ATTENTION : il faut tenir compte de l'inductance du rhéostat 11 Ohms 9A !

Pot RM14 – Matériaux 3C85 – Entrefer $e = ??? \mu\text{m}$ – $N = ???$ spires – Fils 2 x AWG19 ($\phi 1 \text{ mm}$) ?

$\mu_e = 2000$ – $A_e = 198 \text{ mm}^2$ – $L_e = 70 \text{ mm}$ – $\mu_0 = 4 \cdot \pi \cdot 10^{-7}$

$$L = N^2 \cdot \frac{\mu_0 \cdot \mu_e \cdot A_e}{L_e} \cdot \frac{1}{1 + \frac{2 \cdot e \cdot \mu_e}{L_e}} = ??? \mu\text{H}$$

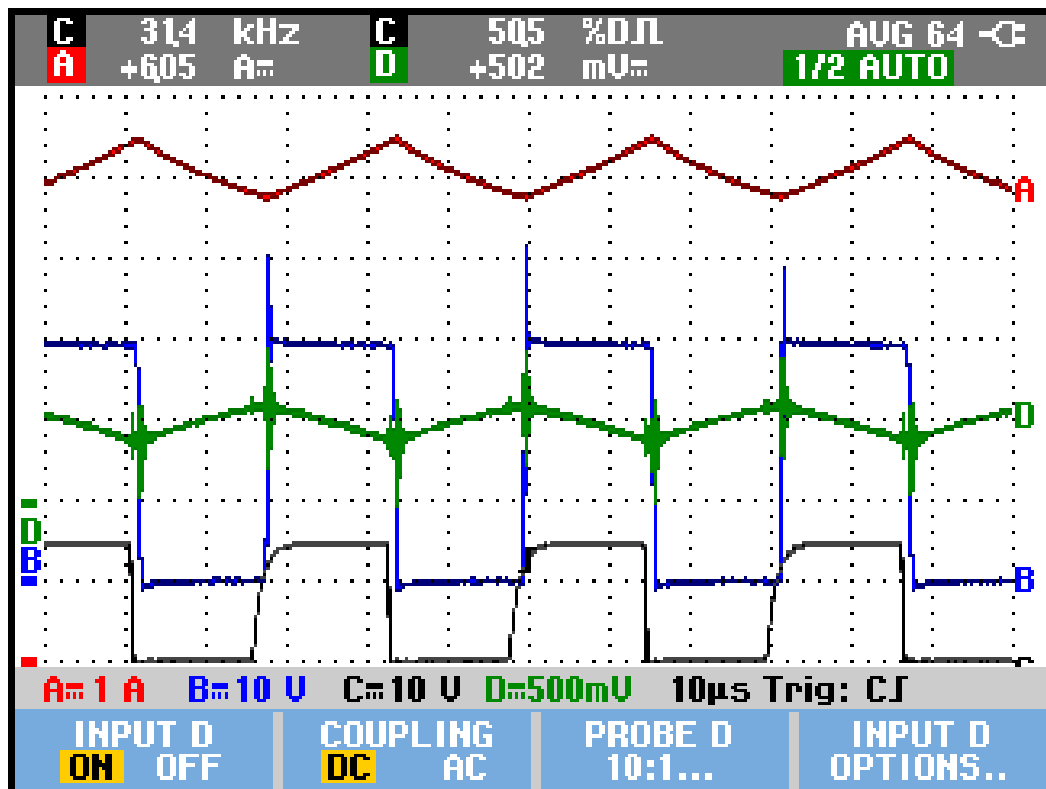
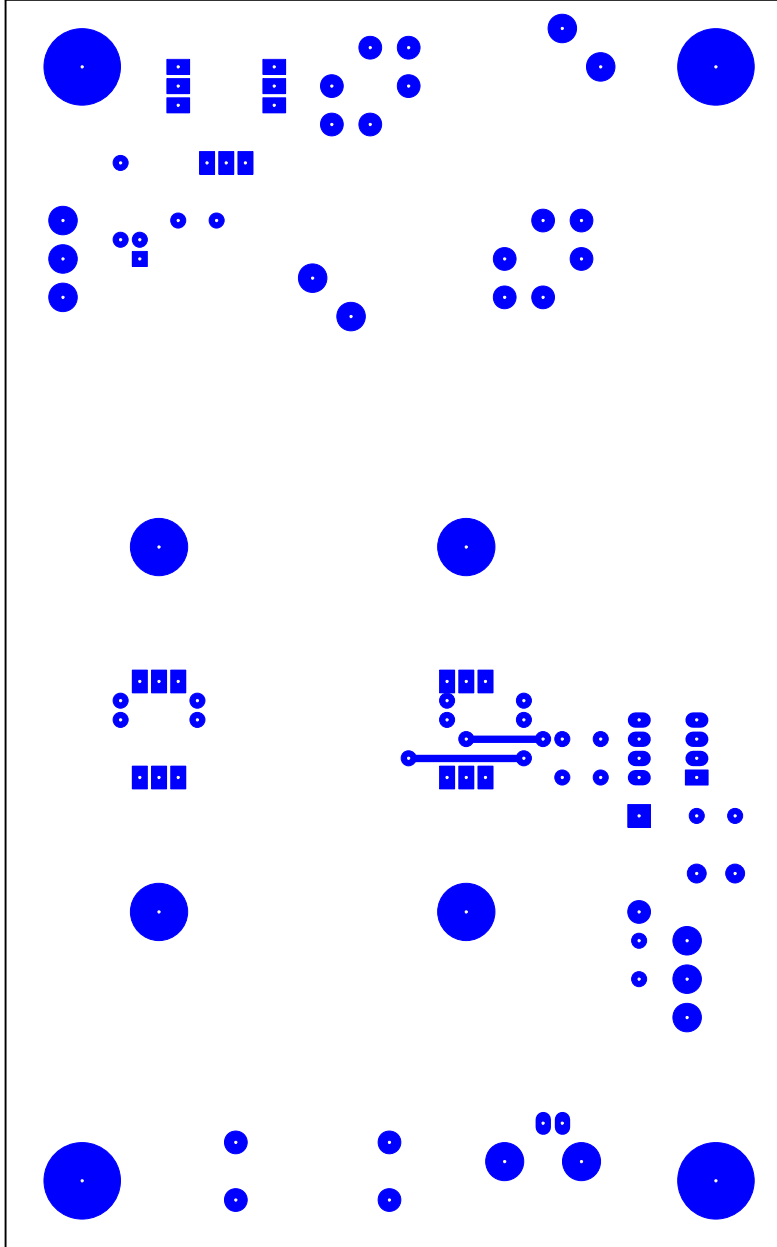
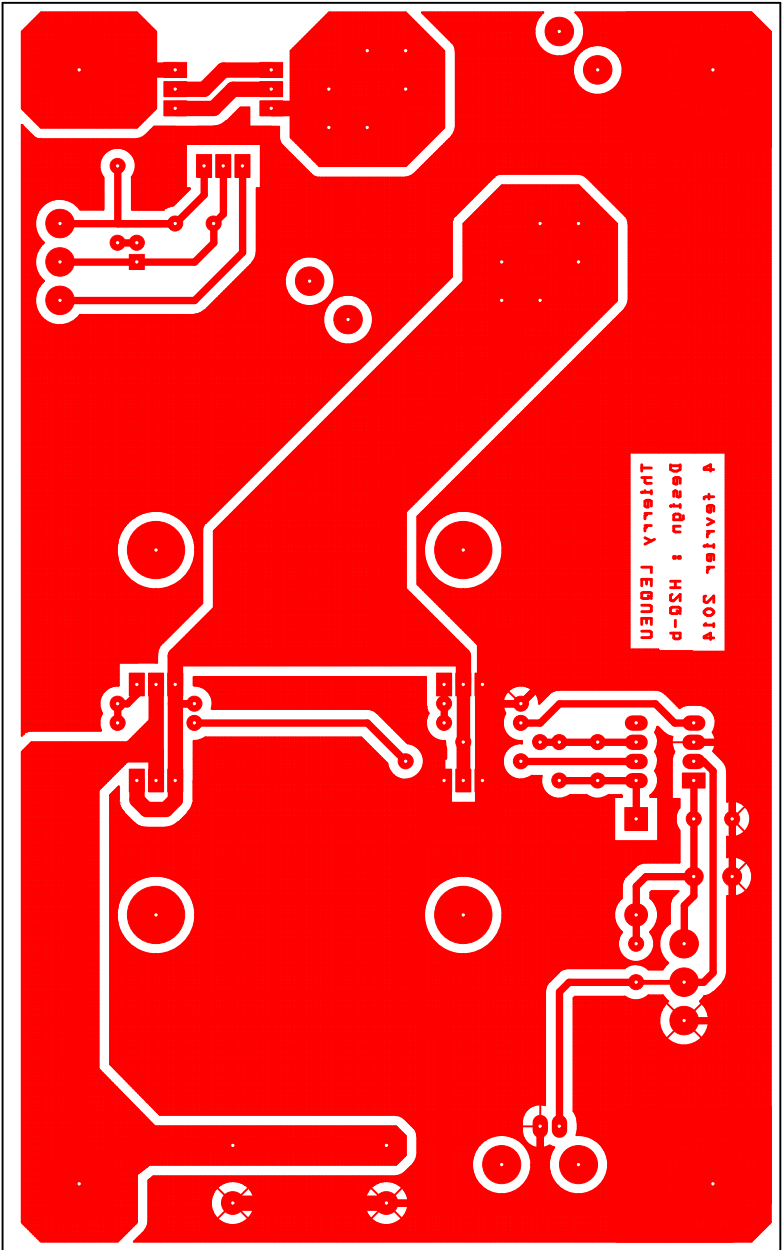
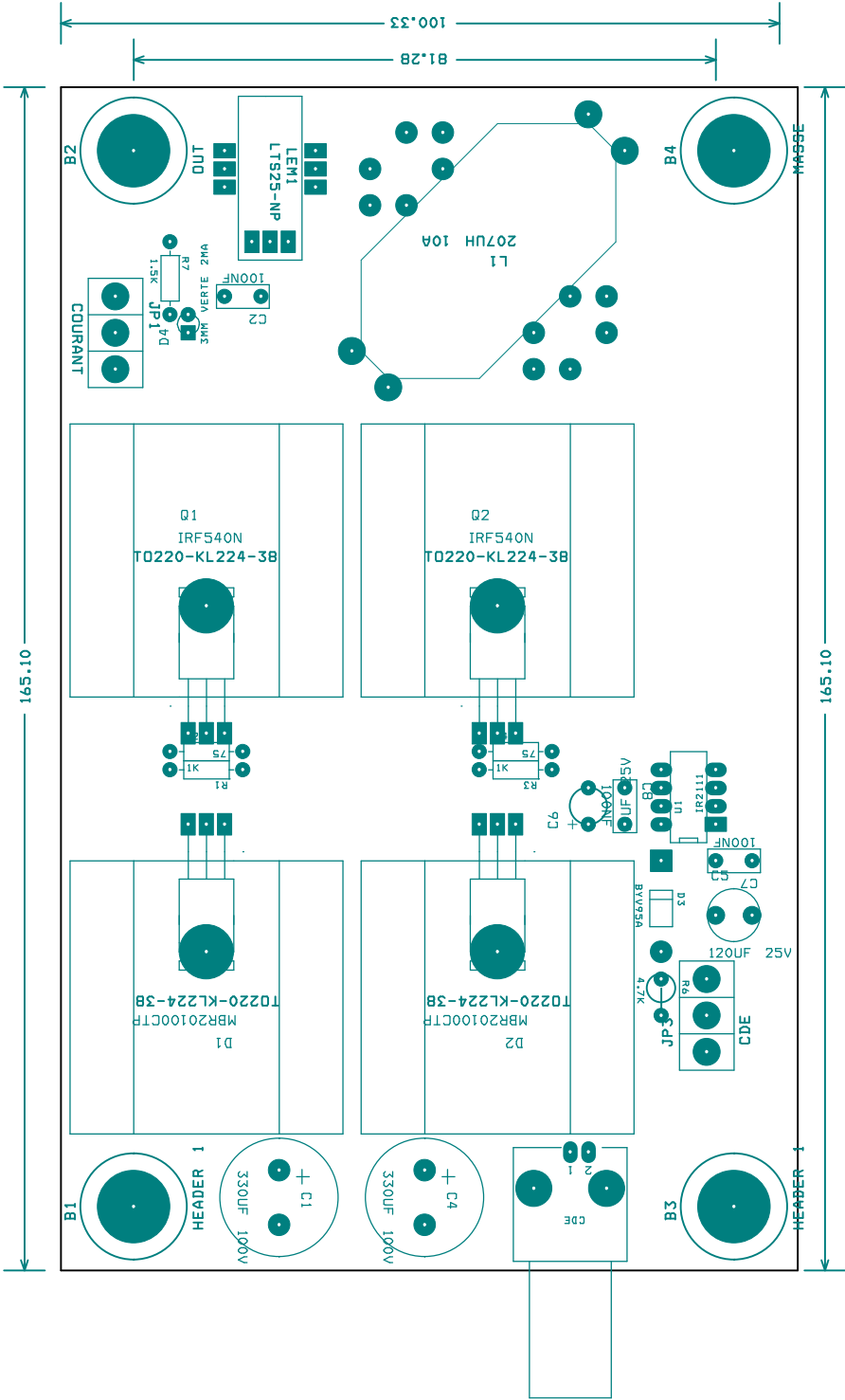
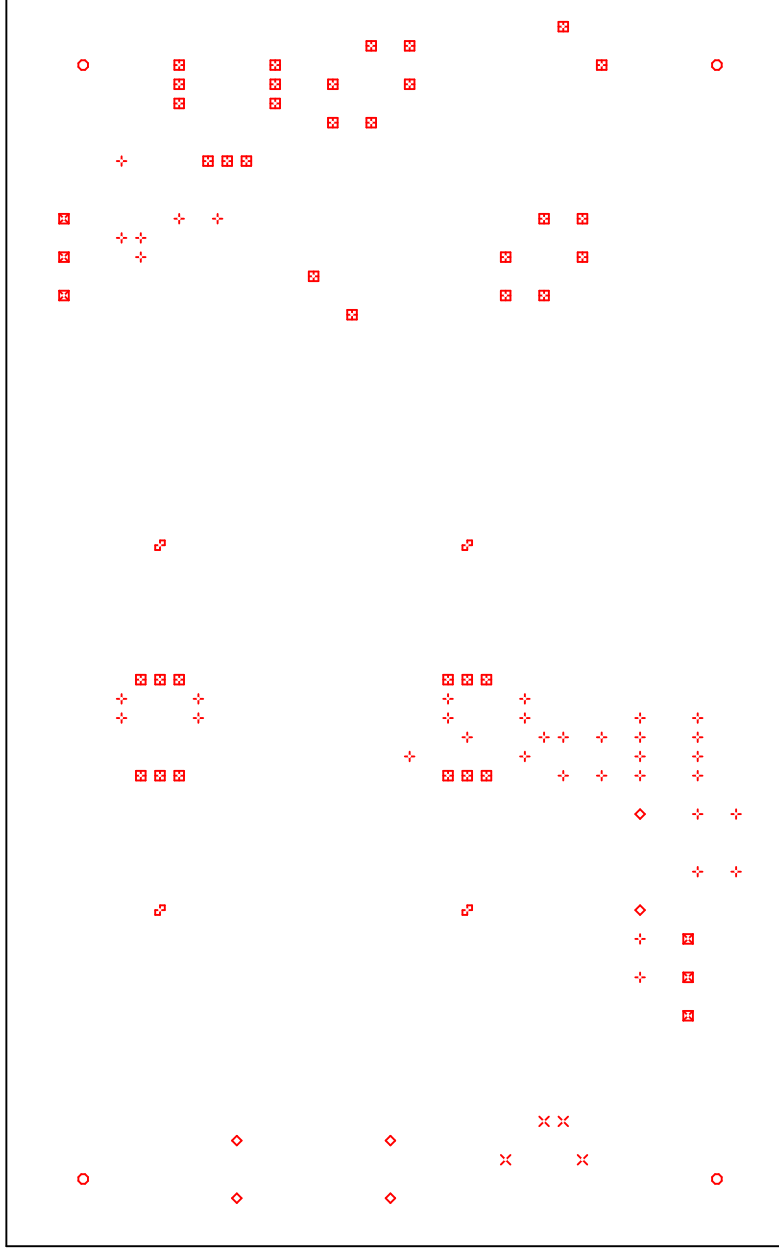

Fig. 11.12. Courant de l'inductance et tension de sortie du capteur de courant (2014-02-06-Mesures\2014-02-07-H2Q-B-2.bmp).









DRILL CHART				
SYM	DIAM	TOL	QTY	NOTE
X	0.020		4	
+	0.031		36	
◇	0.039		6	
⊠	0.039		6	
⊞	0.047		37	
⊚	0.126		4	
○	0.165		4	
TOTAL			97	

Hacheur 2 quadrants 60V 10A
Revised: Wednesday, October 15, 2003
Projet IUT3 / [DIV414] / H2Qb Revision: 1

1 euro #####

Référence	Qu	Désignation	Fournisseur	Date	Code Cde	U.d.V.	Prix U	Prix T.	
B1, B2	2	Embase mm à visser RO	Radiospares	octobre-03	230-6344	1	, €	, €	43,95 F
B3, B4	2	Embase mm à visser NO	Radiospares	octobre-03	230-6350	1	, €	, €	43,95 F
C4,C1	2	330uF 100V	Radiospares	octobre-03	315-1094	5	#####	, €	29,23 F
C2,C7,C8	3	100nF	Radiospares	octobre-03	166-8433 315-	10	, €	, €	3,54 F
C5	1	120uF 25V	Radiospares	octobre-03	0546	5	, €	, €	1,59 F
C6	1	10uF 25V	Radiospares	octobre-03	315-0805	5	, €	, €	1,25 F
D1,D2	2	MBR20100CTP	Radiospares	octobre-03	447-3351	1	, €	, €	129,35 F
D3	1	BYV95A	Radiospares	octobre-03	196-1007 446-	5	, €	, €	2,23 F
JP1, JP3	2	Bornier plots à visser	Radiospares	octobre-03	7234	5	, €	, €	6,03 F
JP4	1	BNC ohms coudée pou	Radiospares	octobre-03	477-090	1	, €	, €	21,97 F
LEM1	1	LTS25-NP	Radiospares	octobre-03	301-0472 305-	1	#####	, €	118,79 F
L1	1	POT RM14/I-3C90	Farnell	octobre-03	6867	1	, €	, €	38,05 F
L1	1	Bobine RM14	Farnell	octobre-03	200-657	1	, €	, €	24,93 F
L1	1	Clips pour pot RM14	Farnell	octobre-03	291-432	1	, €	, €	3,35 F
L1	6	Fils de cuivre AWG 19	Radiospares	octobre-03	357-788	80	#####	, €	4,93 F
Q1,Q2	2	IRF540N	Radiospares	octobre-03	244-0526	1	, €	, €	43,29 F
R1,R3	2	75	IUT GEII	octobre-03	résistanc	1	, €	, €	0,13 F
R2,R4	2	1k	IUT GEII	octobre-03	résistanc	1	, €	, €	0,13 F
R6	1	4.7k	IUT GEII	octobre-03	résistanc	1	, €	, €	0,07 F
U1	1	IR2111	Radiospares	octobre-03	189-0501	1	, €	, €	56,94 F
Divers	4	Dissipateurs KL-224, 38	Radiospares	octobre-03	218-2255	1	, €	, €	49,59 F
Divers	4	Vis CTF M3x20	Radiospares	octobre-03	560-798	100	, €	, €	0,76 F
Divers	4	Ecroux M3	Radiospares	octobre-03	560-293	250	, €	, €	0,48 F
Divers	4	Rondelles frein M3	Radiospares	octobre-03	526-574	250	, €	, €	0,22 F
Divers	1	Support tulipe 8 broches	Radiospares	octobre-03	100-9935	10	, €	, €	2,83 F
Divers	##	Circuit imprimé x	IUT GEII	octobre-03	CI	600	#####	, €	25,90 F

TOTAL H.T. :	, €	653,46 F
#####	, €	134,61 F
TOTAL T.T.C. :	, €	788,08 F

RM cores and accessories

RM14/I

CORE SETS

Effective core parameters

SYMBOL	PARAMETER	VALUE	UNIT
$\Sigma(I/A)$	core factor (C1)	0.353	mm ⁻¹
V_e	effective volume	13900	mm ³
l_e	effective length	70.0	mm
A_e	effective area	198	mm ²
A_{min}	minimum area	168	mm ²
m	mass of set	≈74	g

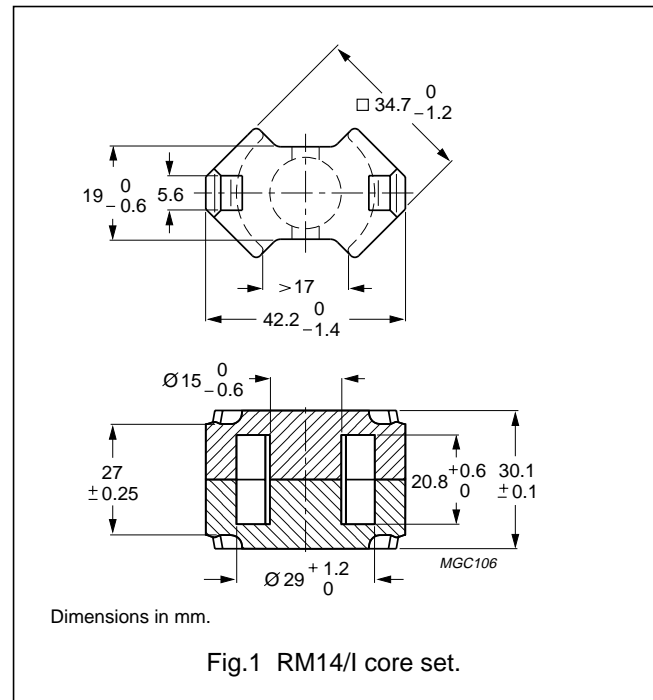

Core sets for general purpose transformers and power applications

Clamping force for A_L measurements, 80 ±20 N.

GRADE	A_L (nH)	μ_e	AIR GAP (μ m)	TYPE NUMBER
3C90	250 ±3%	≈70	≈950	RM14/I-3C90-A250
	315 ±3%	≈88	≈700	RM14/I-3C90-A315
	400 ±3%	112	≈550	RM14/I-3C90-A400
	630 ±5%	≈177	≈250	RM14/I-3C90-A630
	1000 ±5%	≈281	≈150	RM14/I-3C90-A1000
	7100 ±25%	≈1990	≈0	RM14/I-3C90
3C94 <small>des</small>	250 ±3%	≈70	≈950	RM14/I-3C94-A250
	315 ±3%	≈88	≈700	RM14/I-3C94-A315
	400 ±3%	112	≈550	RM14/I-3C94-A400
	630 ±5%	≈177	≈250	RM14/I-3C94-A630
	1000 ±5%	≈281	≈150	RM14/I-3C94-A1000
	7100 ±25%	≈1990	≈0	RM14/I-3C94
3C96 <small>prot</small>	6200 ±25%	≈1740	≈0	RM14/I-3C96
3F3	250 ±3%	≈70	≈950	RM14/I-3F3-A250
	315 ±3%	≈88	≈700	RM14/I-3F3-A315
	400 ±3%	112	≈550	RM14/I-3F3-A400
	630 ±5%	≈177	≈250	RM14/I-3F3-A630
	1000 ±5%	≈281	≈150	RM14/I-3F3-A1000
	5700 ±25%	≈1600	≈0	RM14/I-3F3

RM cores and accessories

RM14/I

COIL FORMERS

General data

PARAMETER	SPECIFICATION
Coil former material	phenolformaldehyde (PF), glass reinforced, flame retardant in accordance with "UL 94V-0"; UL file number E167521(M)
Pin material	copper-tin alloy (CuSn), tin-lead alloy (SnPb) plated
Maximum operating temperature	180 °C, "IEC 60085", class H
Resistance to soldering heat	"IEC 60068-2-20", Part 2, Test Tb, method 1B, 350 °C, 3.5 s
Solderability	"IEC 60068-2-20", Part 2, Test Ta, method 1

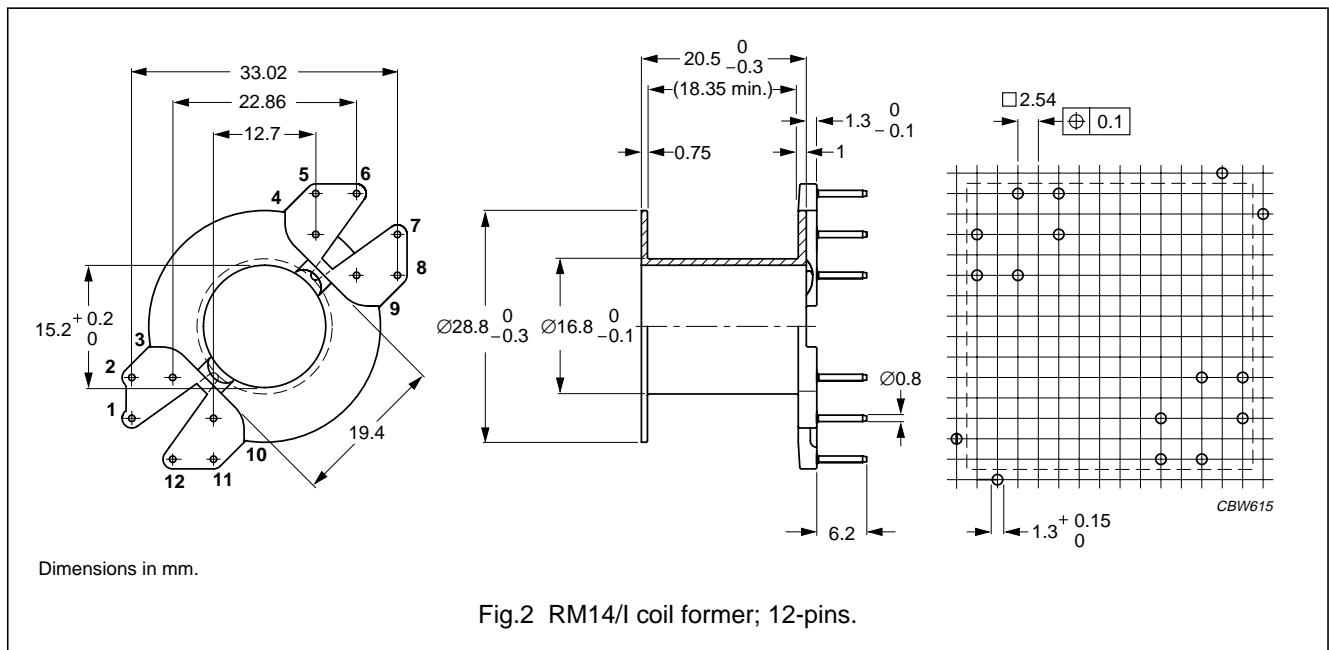

Fig.2 RM14/I coil former; 12-pins.

Winding data for 12-pins RM14/I coil former

NUMBER OF SECTIONS	NUMBER OF PINS	PIN POSITIONS USED	AVERAGE LENGTH OF TURN (mm)	WINDING AREA (mm ²)	WINDING WIDTH (mm)	TYPE NUMBER
1	10	1, 2, 3, 4, 6, 7, 9, 10, 11, 12	71	112	18.4	CSV-RM14-1S-10P
1	12	all	71	112	18.4	CSV-RM14-1S-12P