

DESIGN TIP

DT 98-2

International Rectifier • 233 Kansas Street El Segundo CA 90245 USA

Bootstrap Component Selection For Control IC's

By Jonathan Adams

TOPICS COVERED

- Operation Of The Bootstrap Circuit*
- Factors Affecting The Bootstrap Supply*
- Calculating The Bootstrap Capacitor Value*
- Selecting The Bootstrap Diode*
- Layout Considerations*

1. OPERATION OF THE BOOTSTRAP CIRCUIT

The V_{bs} voltage (the voltage difference between the V_b and V_s pins on the control IC) provides the supply to the high side driver circuitry of the control IC's. This supply needs to be in the range of 10-20V to ensure that the Control IC can fully enhance the MOS Gated Transistor (MGT) being driven, some of International Rectifier's Control IC's include undervoltage detection circuits for V_{bs} , to ensure that the IC does not drive the MGT if the V_{bs} voltage drops below a certain voltage (V_{bsuv} in the datasheet). This prevents the MGT from operating in a high dissipation mode.

This V_{bs} supply voltage is a floating supply that sits on top of the V_s voltage (which in most cases will be a high frequency square wave). There are a number of ways in which the V_{bs} floating supply can be generated, one of these being the bootstrap method described here in this design tip. This method has the advantage of being simple and inexpensive but has some limitations, duty cycle and on-time are limited by the requirement to refresh the charge in the bootstrap capacitor (long on-times and high duty cycles require a charge pump circuit - see Application Note AN978). The bootstrap supply is formed by a diode and capacitor combination as shown in fig 1).

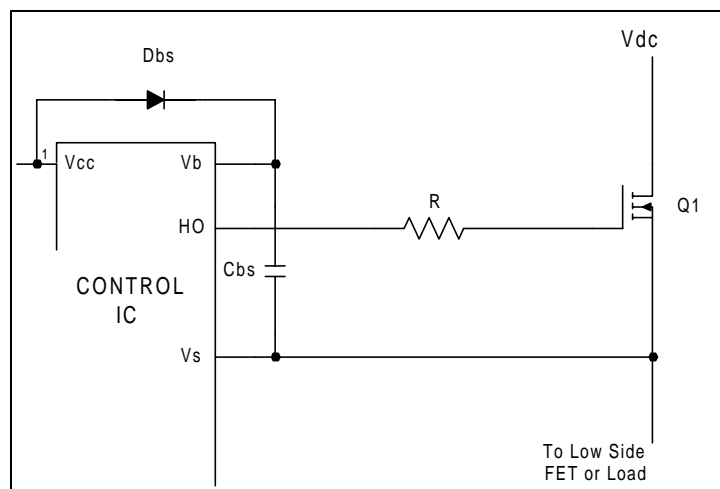

Fig 1) Bootstrap Diode/ Capacitor circuit used with IR Control IC's

The operation of the circuit is as follows. When V_s is pulled down to ground (either through the low side FET or the load, depending on the circuit configuration), the bootstrap capacitor (C_{bs}) charges through the bootstrap diode (D_{bs}) from the 15V V_{cc} supply. Thus providing a supply to V_{bs} .

2. FACTORS AFFECTING THE BOOTSTRAP SUPPLY

There are five influencing factors which contribute to the supply requirement from the V_{bs} capacitor. These are:

1. Gate Charge required to enhance MGT
2. I_{qbs} - quiescent current for the high side driver circuitry
3. Currents within the level shifter of the control IC
4. MGT gate-source forward leakage current
5. Bootstrap capacitor leakage current

Factor 5 is only relevant if the bootstrap capacitor is an electrolytic capacitor, and can be ignored if other types of capacitor are used. Therefore it is always better to use a non-electrolytic capacitor if possible.

3. CALCULATING THE BOOTSTRAP CAPACITOR VALUE

The following equation details the minimum charge which needs to be supplied by the bootstrap capacitor:

$$Q_{bs} = 2Q_g + \frac{I_{qbs(max)}}{f} + Q_{ls} + \frac{I_{Cbs(leak)}}{f} \quad \text{EQ(1)}$$

where:

Q_g =Gate charge of high side FET

f =frequency of operation

$I_{Cbs(leak)}$ =Bootstrap capacitor leakage current

Q_{ls} = level shift charge required per cycle = 5nC (500V/600V IC's) or 20nC (1200V IC's)

The bootstrap capacitor must be able to supply this charge, and retain its full voltage, otherwise there will be a significant amount of ripple on the V_{bs} voltage, which could fall below the V_{bsuv} undervoltage lockout, and cause the HO output to stop functioning. Therefore the charge in the C_{bs} capacitor must be a minimum of twice the above value. The minimum capacitor value can be calculated from the equation below.

$$C \geq \frac{2 \left[2Q_g + \frac{I_{qbs(max)}}{f} + Q_{ls} + \frac{I_{Cbs(leak)}}{f} \right]}{V_{cc} - V_f - V_{LS}} \quad \text{EQ(2)}$$

Where:

V_f = Forward voltage drop across the bootstrap diode

V_{LS} = Voltage drop across the low side FET
(or load for a high side driver)

IMPORTANT NOTE: The C_{bs} Capacitor value obtained from the above equation EQ(2) is the absolute minimum required, however due to the nature of the bootstrap circuit operation, a low value capacitor can lead to overcharging, which could in turn damage the IC. Therefore to minimize the risk of overcharging and further reduce ripple on the V_{bs} voltage the C_{bs} value obtained from the above equation should be multiplied by a factor of 15 (rule of thumb).

The C_{bs} capacitor only charges when the high side device is off, and the V_s voltage is pulled down to ground. Therefore the on time of the low side switch (or the off time of the high side switch for a high side driver) must be sufficient to ensure that the charge drawn from the C_{bs} capacitor by the high side driver, can be fully replenished. Hence there is inherently a minimum on time of the low side switch (or off time of the high side switch in a high side driver). Also in a high side switch configuration where the load is part of the charge path, the impedance of the load can have a significant

effect on the charging of the C_{bs} bootstrap capacitor - if the impedance is too high the capacitor will not be able to charge properly, and a charge pump circuit may be required (see Application Note AN978).

4. SELECTING THE BOOTSTRAP DIODE

The bootstrap diode (D_{bs}) needs to be able to block the full power rail voltage, which is seen when the high side device is switched on. It must be a fast recovery device to minimize the amount of charge fed back from the bootstrap capacitor into the V_{cc} supply, and similarly the high temperature reverse leakage current would be important if the capacitor has to store charge for long periods of time. The current rating of the diode is the product of the charge calculated from equation EQ(1) and the switching frequency.

Therefore:

Diode Characteristics

$$\begin{aligned} V_{RRM} &= \text{Power rail voltage} \\ \max t_{tr} &= 100\text{ns} \\ I_F &= Q_{bs} \times f \end{aligned}$$

5. LAYOUT CONSIDERATIONS

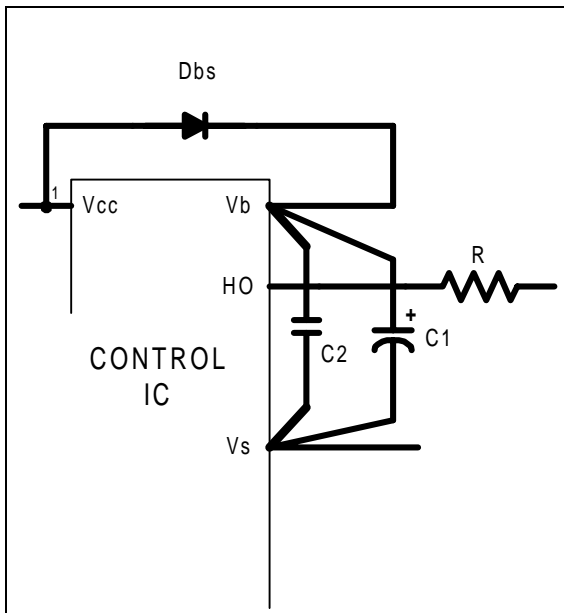

Fig 2) Recommended layout of the Bootstrap Components

The Bootstrap capacitor should always be placed as close to the pins of the IC as possible (as shown in Fig 2 on the left).

At least one low ESR capacitor should be used to provide good local de-coupling, e.g. a separate ceramic capacitor close to the IC would be essential if an aluminum electrolytic capacitor is used for the bootstrap capacitor. If the bootstrap capacitor is either a ceramic or tantalum type, this should be sufficient in itself as the local decoupling.