

Amplificateur audio 12 Volts



Introduction

- * Cahier des charges
- * Création de l'amplificateur
- * Améliorations envisageables

DVD disc

MP3 CD VIDEO



Cahier des charges

—▶ Finalité du produit

—▶ Contraintes

1. **Électrique**

2. **Connexions audio variées**

3. **Réglages**

4. **Boîtier**

5. **Budget**

—▶ Schéma bloc du système

Création

Amplificateur

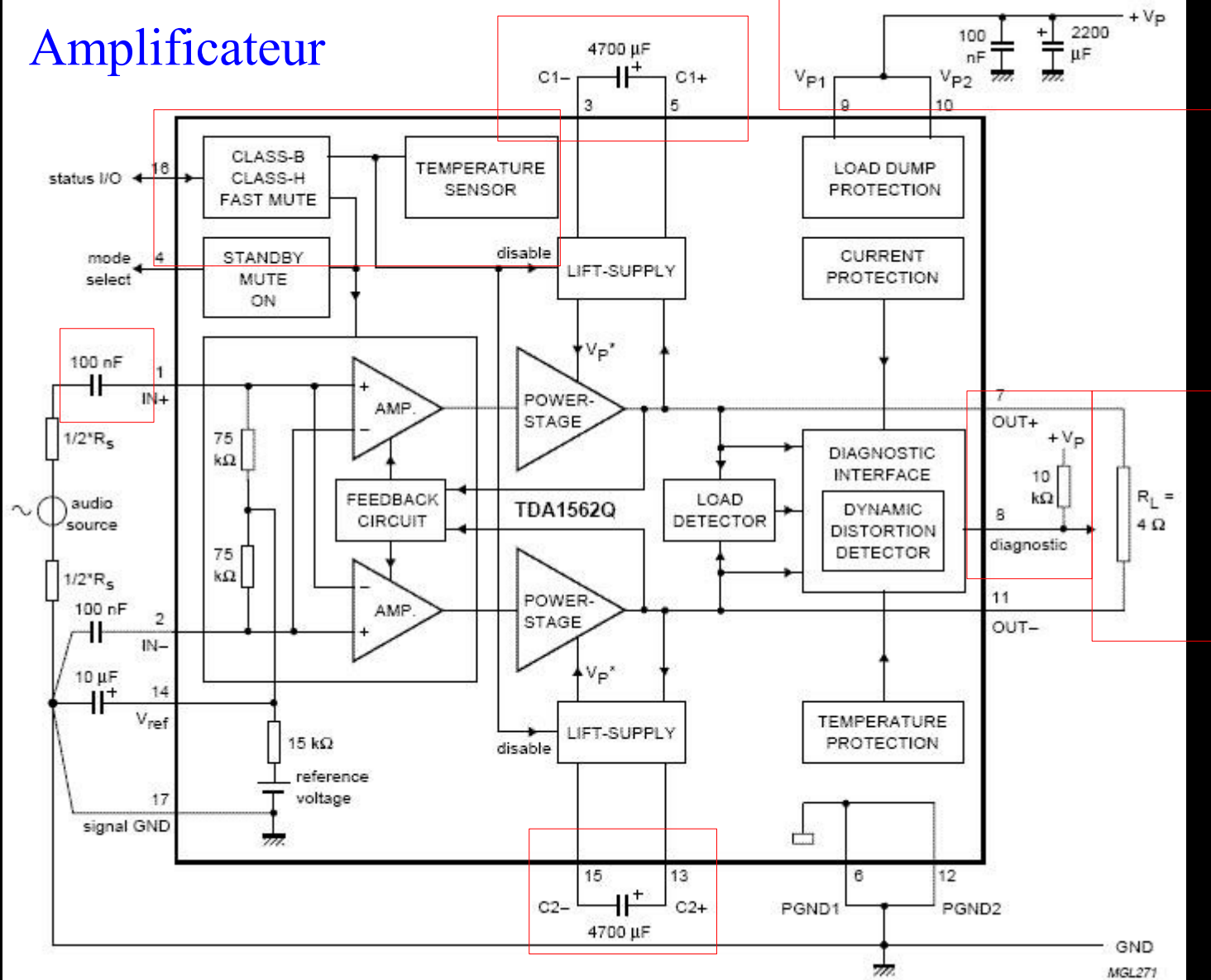

Création

→ TDA1562Q



Amplificateur audio 12 Volts

Création

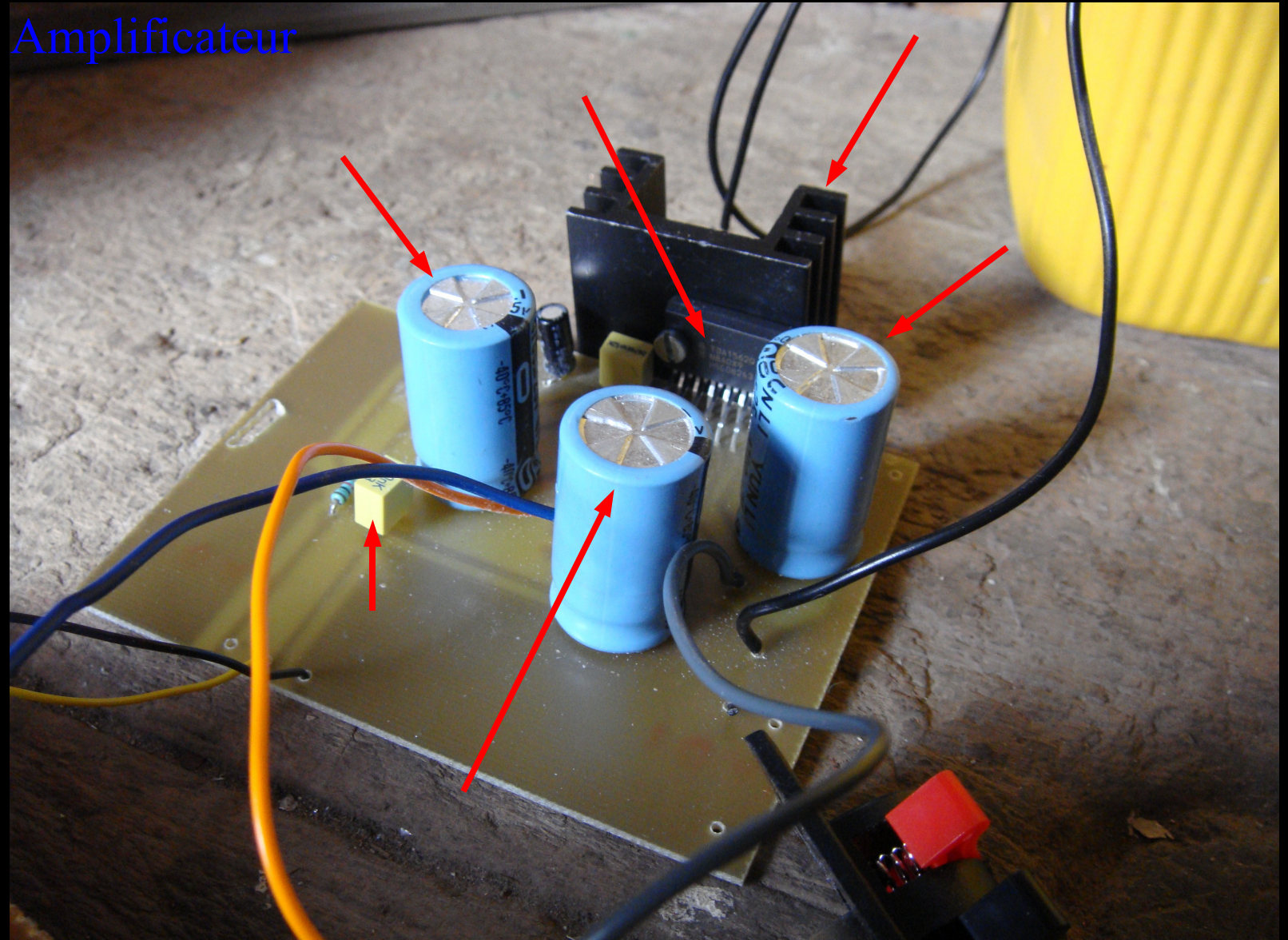

Amplificateur

Amplificateur audio 12 Volts

Création

→ Préamplificateur

Mono

Boost

Volume guitare

Stéréo

Volume 2
voies

Volume MP3

Tonalité 2
voies

Réglage MP3

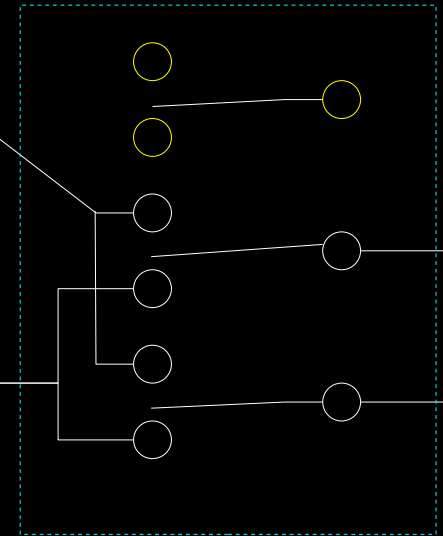

Ampl1

Création

→ Préamplificateur

→ Schéma du Boost

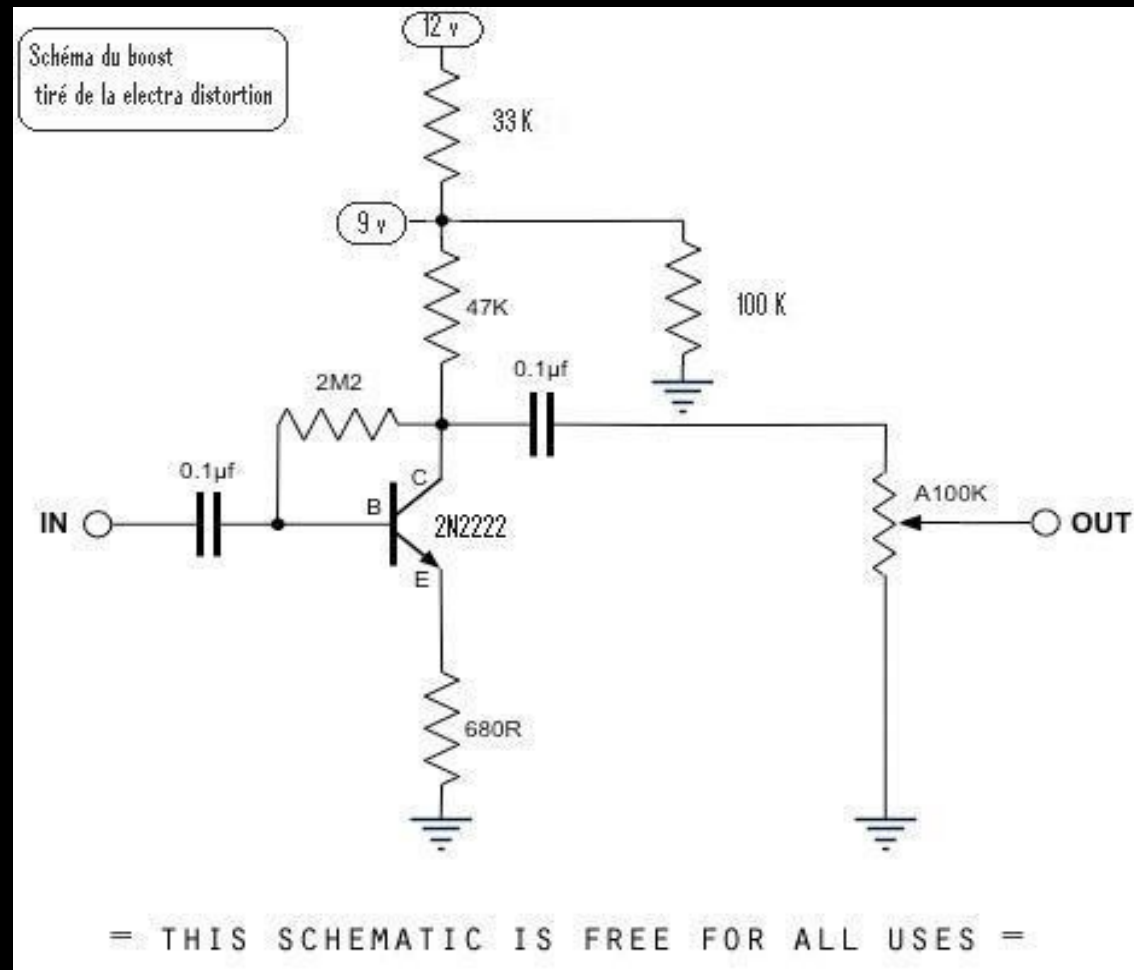

Création

→ Préamplificateur

→ Schéma du Volume MP3

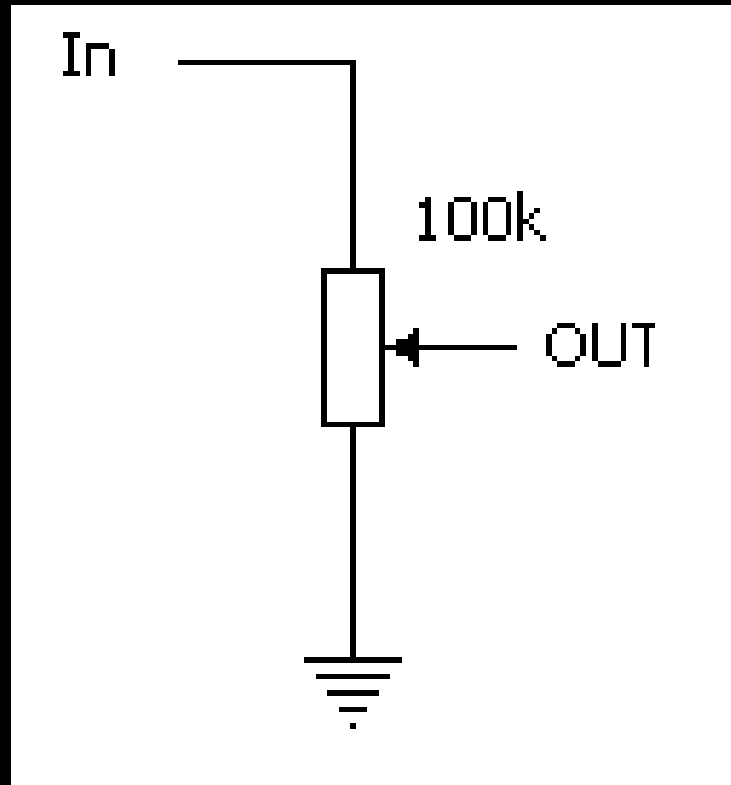

Création

→ Préamplificateur

→ Schéma de la tonalité MP3



Diagramme de Bode

Amplificateur audio 12 Volts

Démonstration

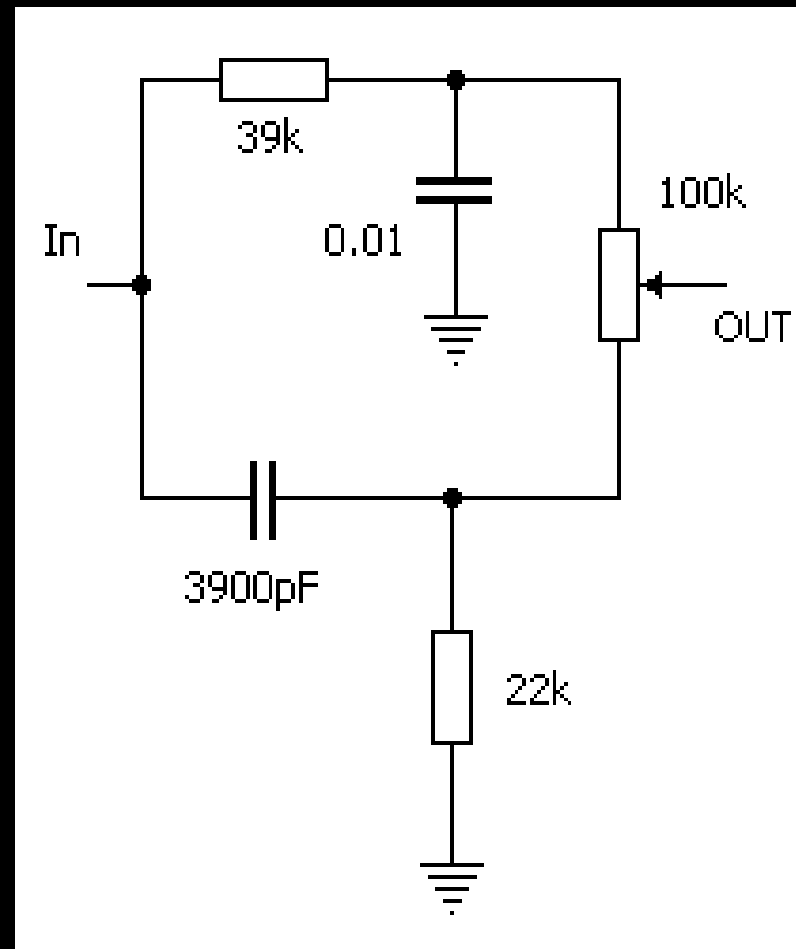

Amplificateur audio 12 Volts

Améliorations envisageables

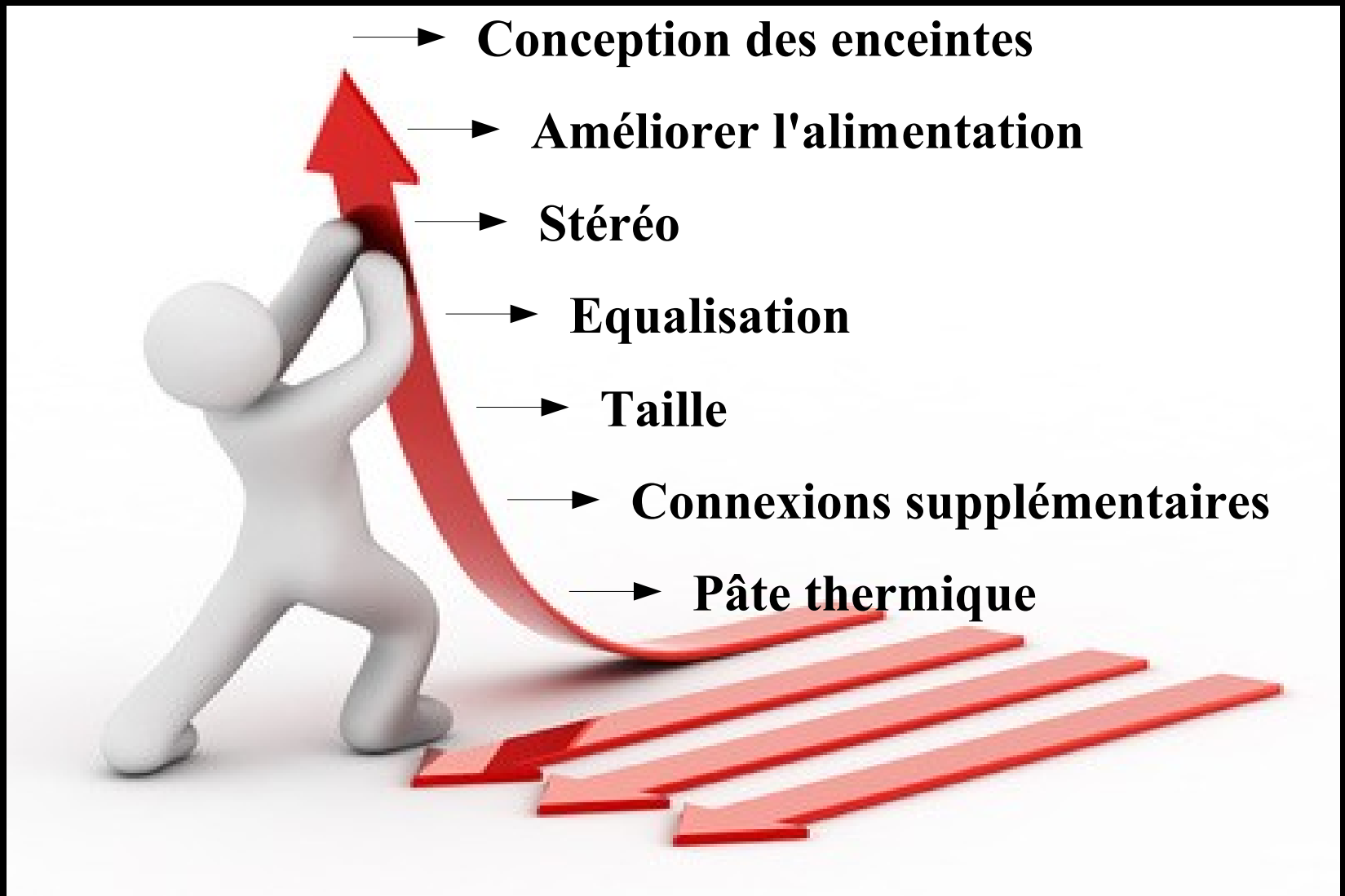

Planning

	4	5	6	7	8	9	10	11	12	13	14
Étude	Red	Red									
	Blue	Blue									
Amplification		Red	Red	Red							
		Blue	Blue	Blue			Blue	Blue			
Pré amplification							Red	Red	Red	Red	Red
				Blue			Blue	Blue	Blue		
Tests				Red					Red	Red	
				Blue				Blue	Blue	Blue	
Wincircuit			Red					Red			
			Blue								
Oral										Red	Red
										Blue	Blue
Rédaction										Red	Red
					Blue					Blue	

Conclusion



th.mann
MUSIC IS OUR PASSION

Remerciements

Franck Saillant

Thierry Lequeu et le club e-Kart

Le site Muzique.com

Le forum Techniguitare.com