

SCR's AND TRIACS IN AUTOMOTIVE APPLICATIONS

P.RAULT

INTRODUCTION

In power electronics the choice of the switch to be used is always very important for the designer : cost, reliability, ruggedness and easiness to be driven must be permanently kept in mind. This is specially important in automotive where the designer has to optimize the numerous switching devices implemented for a wide field of applications : ignition circuits, various electric motor controls, actuators in security systems, etc...

In the large family of electronic switches, the thyristor must be considered as a low cost and powerful device for many functions in a car. This paper reminds the reader of the main characteristics of the thyristors and their advantages in certain automotive applications.

Some examples are presented to illustrate how SCR's and triacs can bring innovative solutions in new electronic designs.

THE THYRISTOR

In fact the term "thyristor" defines a silicon bipolar semi-conductor family including any switch whose bistable action depends on PN-PN regenerative feed back. The main members of this family are the SCR and the Triac (see appended table).

On the other hand, this structure is also widely used in the new product family integrating several

"discrete" components to build various power functions. This new integrated circuits range is called ASD™ (Application Specific Discrete).

A/ MAIN CHARACTERISTICS AND BENEFITS

A.1. Switching on

One of the major advantages of the thyristor is its ability to switch from off-state to on-state in response to a low gate current.

According to the type of device used, a gate current of a few tens of microamps or a few milliamp is sufficient to turn the switch on.

The triggering signal can be a short duration pulse in the range of 100 microseconds or less. As soon as the latching current through the device is reached, the switch remains ON and the gate current can be removed. This "memory" effect can be used in a broad area of applications, reducing the consumption of drivers and saving auxiliary components.

An important point worth noting here is the four quadrants triggering capability of triacs. Whatever the polarity of the current through the device, it can be fired either with positive or negative gate current. This characteristic allows a wide flexibility in the circuitry (fig.1).

Fig. 1 : Triac triggering in the 4 quadrants

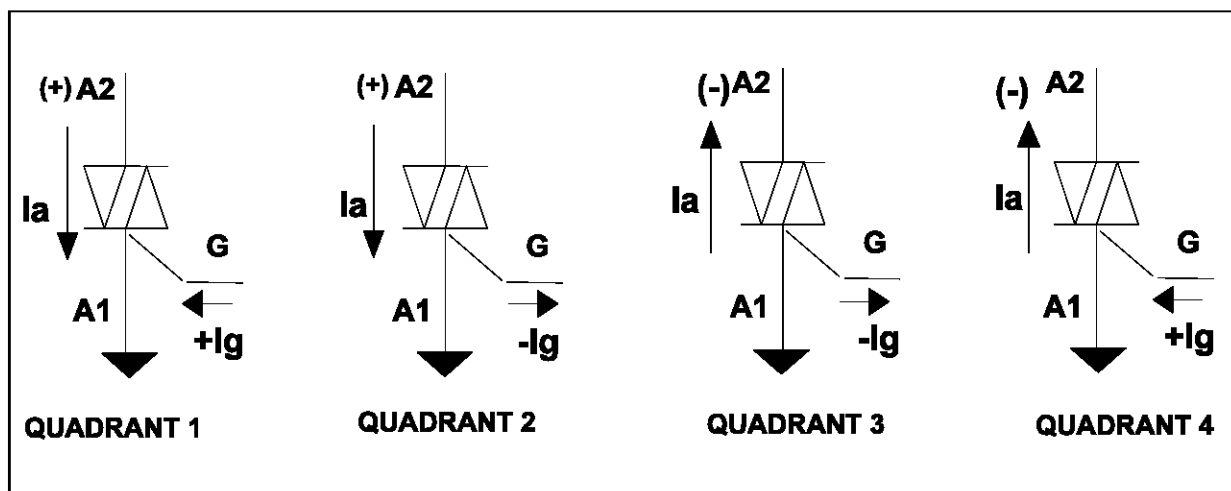

APPLICATION NOTE

A.2. on - state

In conduction, the thyristor structure is autosaturated and the voltage drop is in the order of 1 to 2 volts for a current density in the range of 1 to 10 A/mm².

This switch can operate with average currents in the range of few amps in continuous mode and overall, this on-state characteristic provides a very good behaviour in high current pulse operation (see fig.2).

Fig. 2 : The low voltage drop at high level of current (A) provides a high surge current capability (B)

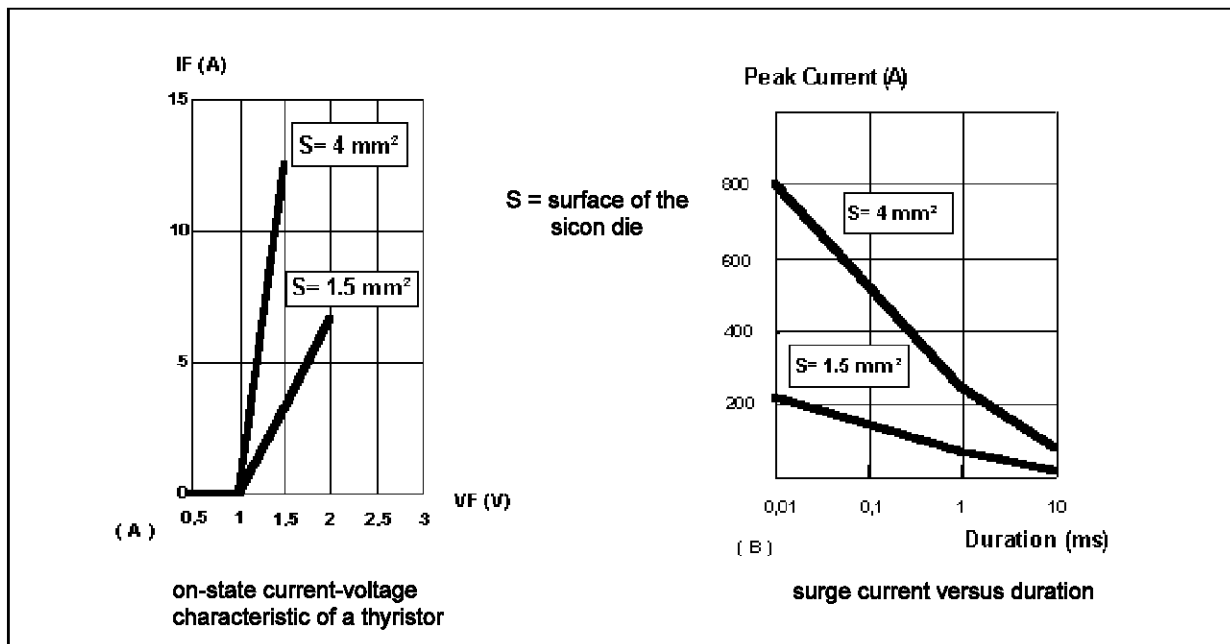

A.3. Switching - off

The thyristor turns off automatically when the load current decreases below the holding current level (IH) which is generally in the range of few milliamps.

In car applications SCR and triacs are ideal for switching circuits associated with relays or any other circuit which use a mechanical or semiconductor switch to interrupt current, and for capacity discharge circuits.

A.4. Benefits

Due to these specific characteristics and properties SCR's and triacs offer to the designer substantial benefits such as :

- * Easy to drive
- * low consumption drive circuit
- * ideal switch for pulse operation (ex : discharge of capacitor)
- * Automatic switching off
- * reverse polarity protection (SCR)
- * bidirectional switch - current and voltage - (triac)
- * high ruggedness

B/ EXAMPLES OF APPLICATION

B.1. Pulse operation circuits

SCR's and triacs are really the most suitable switch for high current pulse operations. They provide very powerful solutions especially in ignition circuits.

B.1.1. Ignition circuits

Used for a very long time (30 years) in small engine ignition, it is today an alternative solution to meet the new requirements in car ignition. In fact, capacitive discharge ignition circuit provides a higher efficiency :

- energy save
- low pollution.

The various existing configurations operate similarly : the energy stored in a capacitor is transferred to a spark gap through a transformer and a SCR.

The figures 3 and 4 show the typical ignition circuits using SCR's.

Fig. 3 : Ignition circuit with SCR: storage capacitor connected in series with input voltage source and pulse transformer

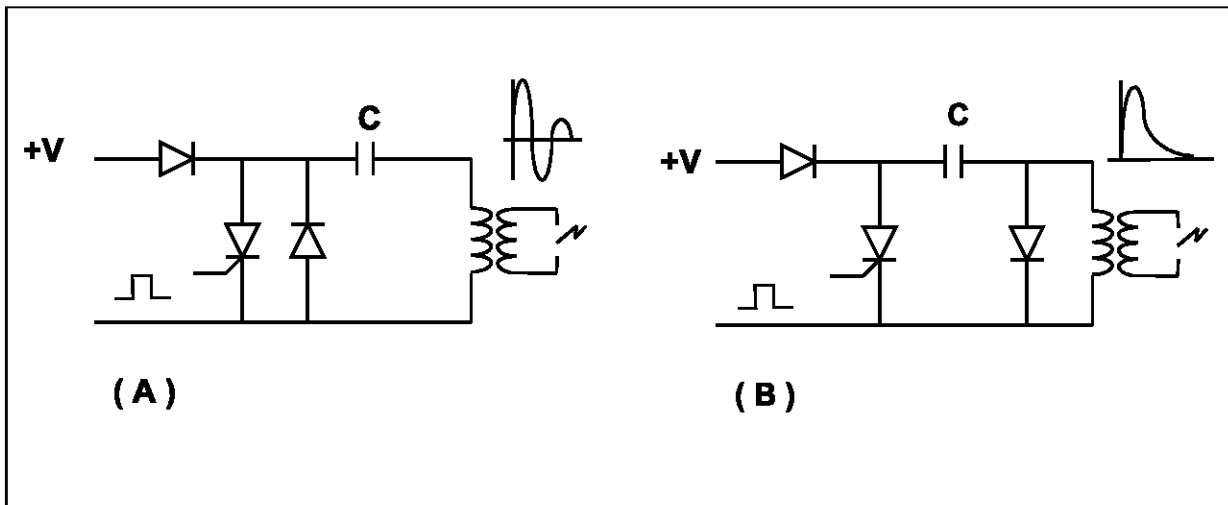
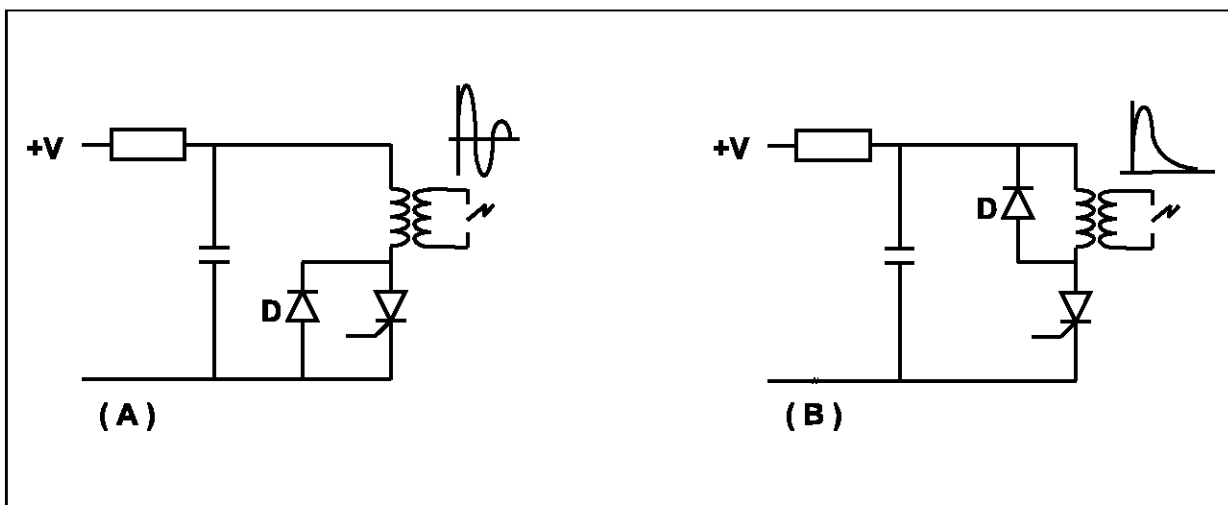

Fig. 4 : Ignition circuit with SCR: storage capacitor connected across input voltage source



In these circuits the diode D acts as a freewheel diode to ensure the complete discharge of the energy stored in the capacitor C.

The current through the transformer is oscillating in the cases 3A and 4A and unidirectional in the cases 4A and 4B.

Utilization of triac

The triac can be used as a very flexible unidirectional or bi-directional switch in such a circuit. Moreover, it can be triggered with a negative gate current. This feature allows the use of standard buffer circuit for the gate control (see fig 5).

APPLICATION NOTE

Fig. 5 : Ignition circuit with Triac: In case B the Triac is triggered by a negative gate current. In case A, no freewheel diode is needed

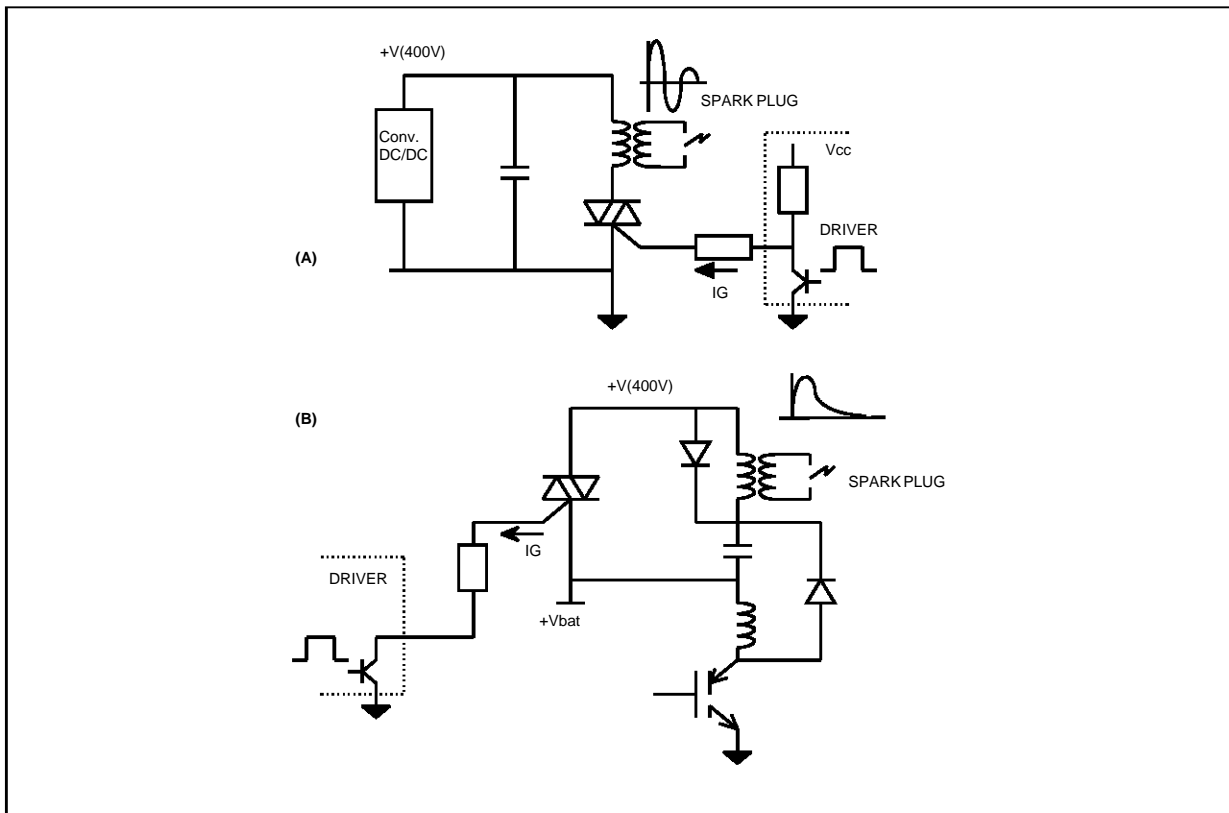

B.1.2. Safety equipments

The discharge of capacitor is also widely used in safety equipment which sets powder trigger mechanism in action : Air bag, belt pretensionner, etc...

In such a system, SCR's are generally the best choice to provide high energy pulse with less than one microsecond response time. Usually, the gate trigger drive of the SCR circuit is very simple and therefore provides a high reliability (Fig.6).

Fig. 6 : Example of application of SCR in safety equipment. The thyristor is turned on when the sensor is activated and discharges the capacitor through the powder firing system

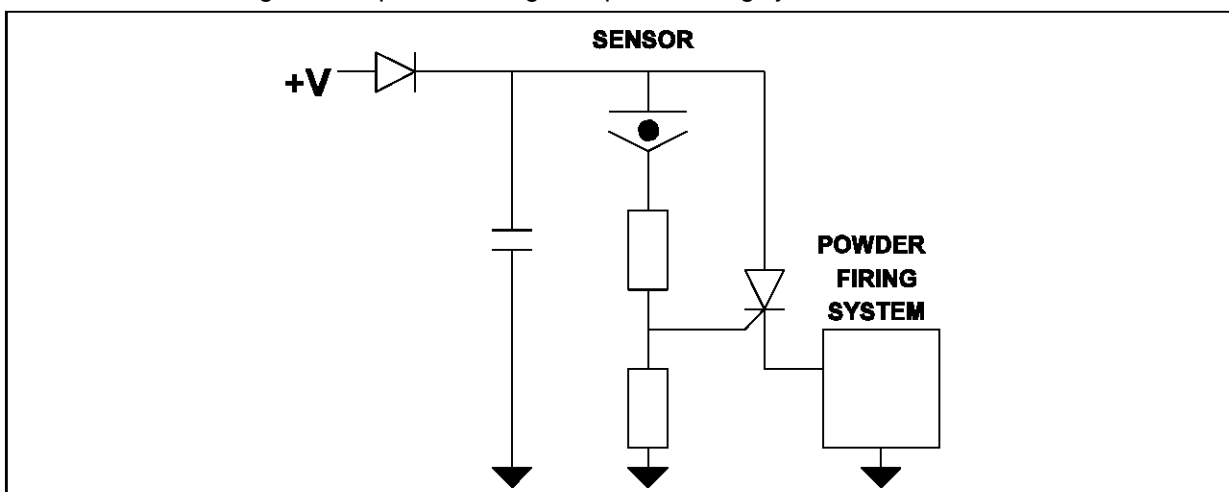

B.2. Bi-directional switch applications

In a car, motors and various actuators require generally the control of the current in both directions : the function is activated and inactivated by reversing the current.

To achieve this bidirectional switching with the conventional technics it is necessary to implement a full bridge : four power mos transistors associated with the heavy gate drive circuit inherent to this topology.

We propose a "one-device" solution : the triac. It is the unique switch able to control the current in both directions.

A good example is the central door lock system shown below.

B.2.1. Central door lock circuit

In this application two relays with change over contact achieve the function "locking" and "unlocking". In some new models, a switch is connected in series with each lock motor in order to control separately each door (Fig.7).

Fig. 7 : Typical circuit using triac as a bidirectional switch to control each door separately.

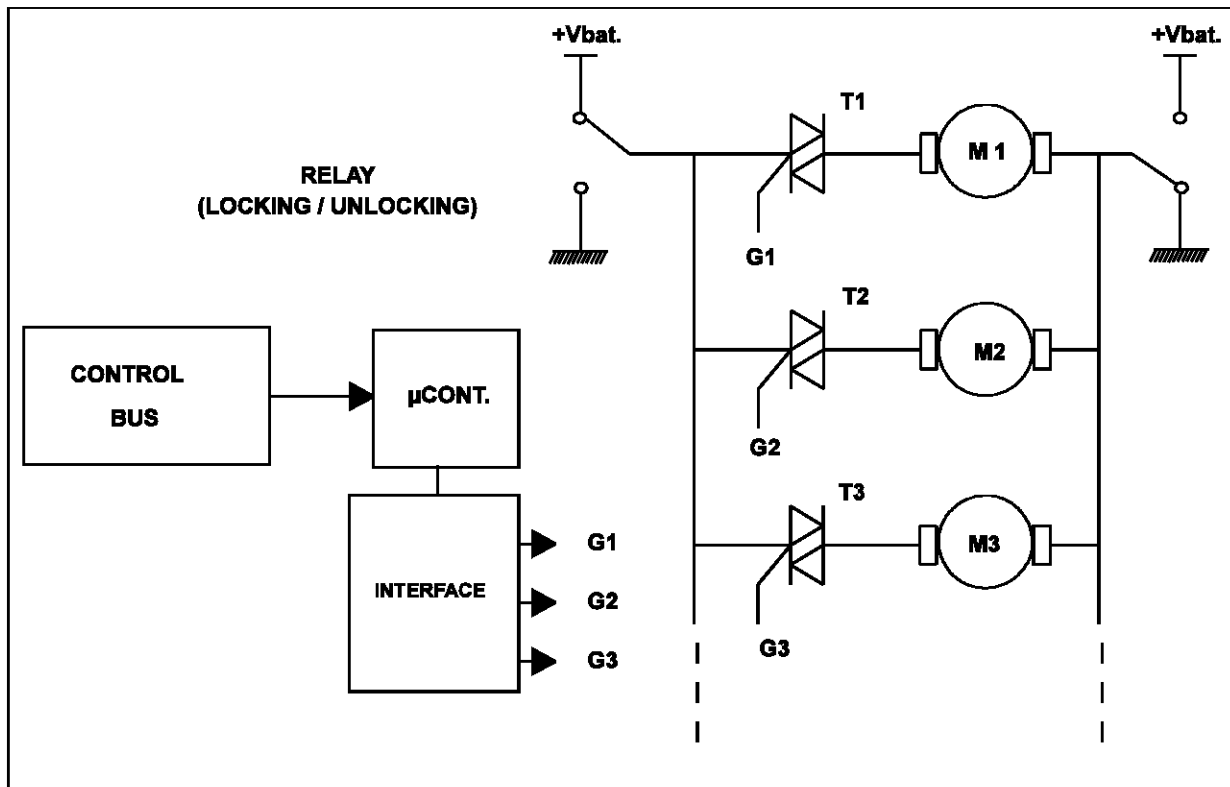

Gate control circuit

In this circuit, the terminal A1 of the triac is sometimes connected to the ground or to the battery voltage. Therefore, a small interface circuit is needed to drive the gate from a standard micro-controller out put.

This interface circuit can be done either with passive components (AC coupling with a capaci-

tor) or with transistor and diodes providing a direct coupling more interesting to use standard triac without particular requirement concerning gate triggering current (See fig.8).

APPLICATION NOTE

Fig. 8 : Example of gate drive interface circuits

(A) : the triac is always fired by a negative gate current pulse (Quadrants II and III)

(B) : the triac is fired by a negative gate current via D1 when A1 is grounded (QII) and a positive gate current via D2 and T1 when A1 is at +Vbat (QI)

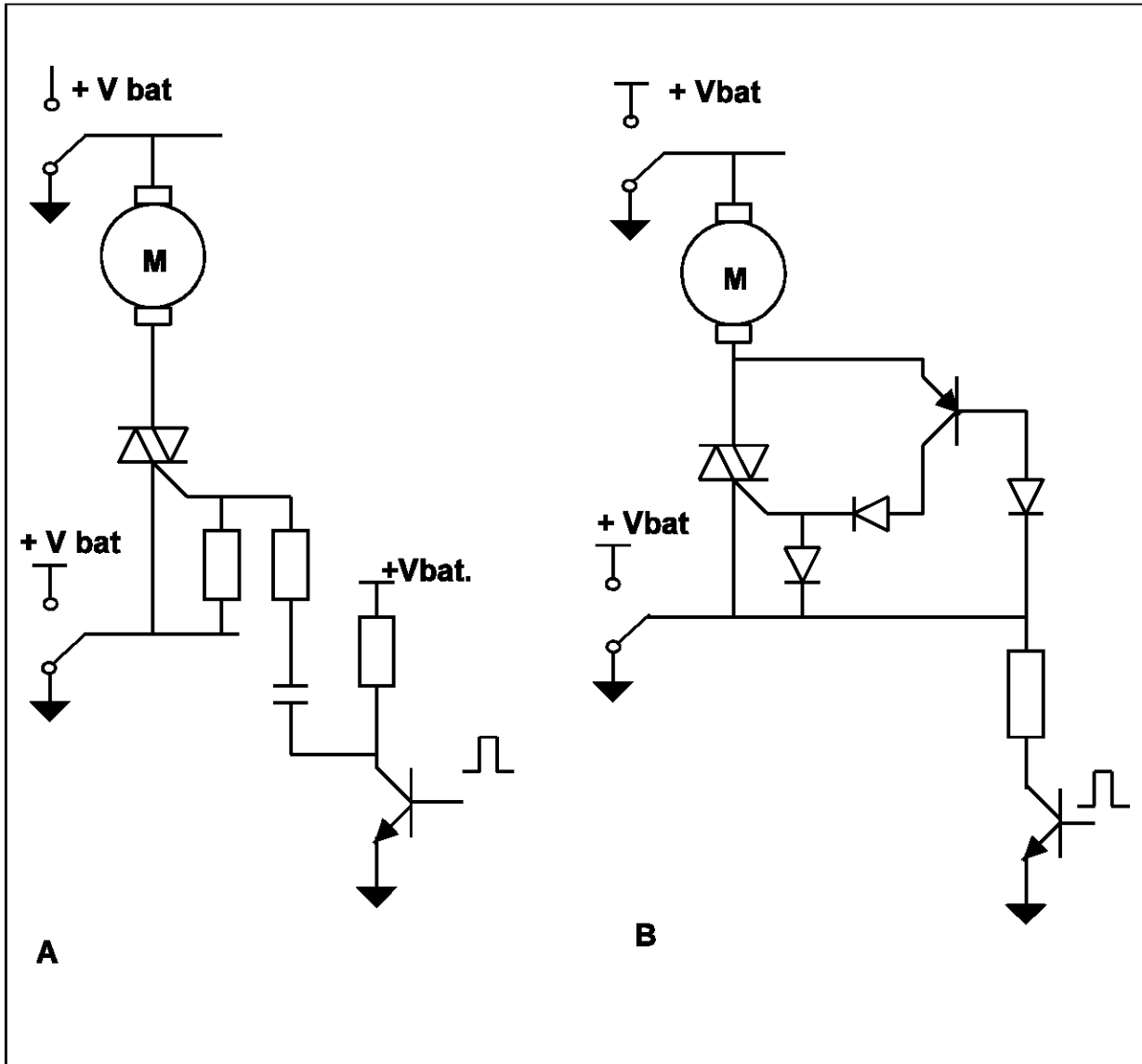

B.2.2. Going further

Starting from this concept using only one triac per motor, we can imagine a "smart door" board designed to control the functions set up in a car front door (See fig.9). This solution provides the lowest cost per channel.

Fig. 9 : "Smart door control" concept based on small triacs to drive each actuator of the various functions of the front door

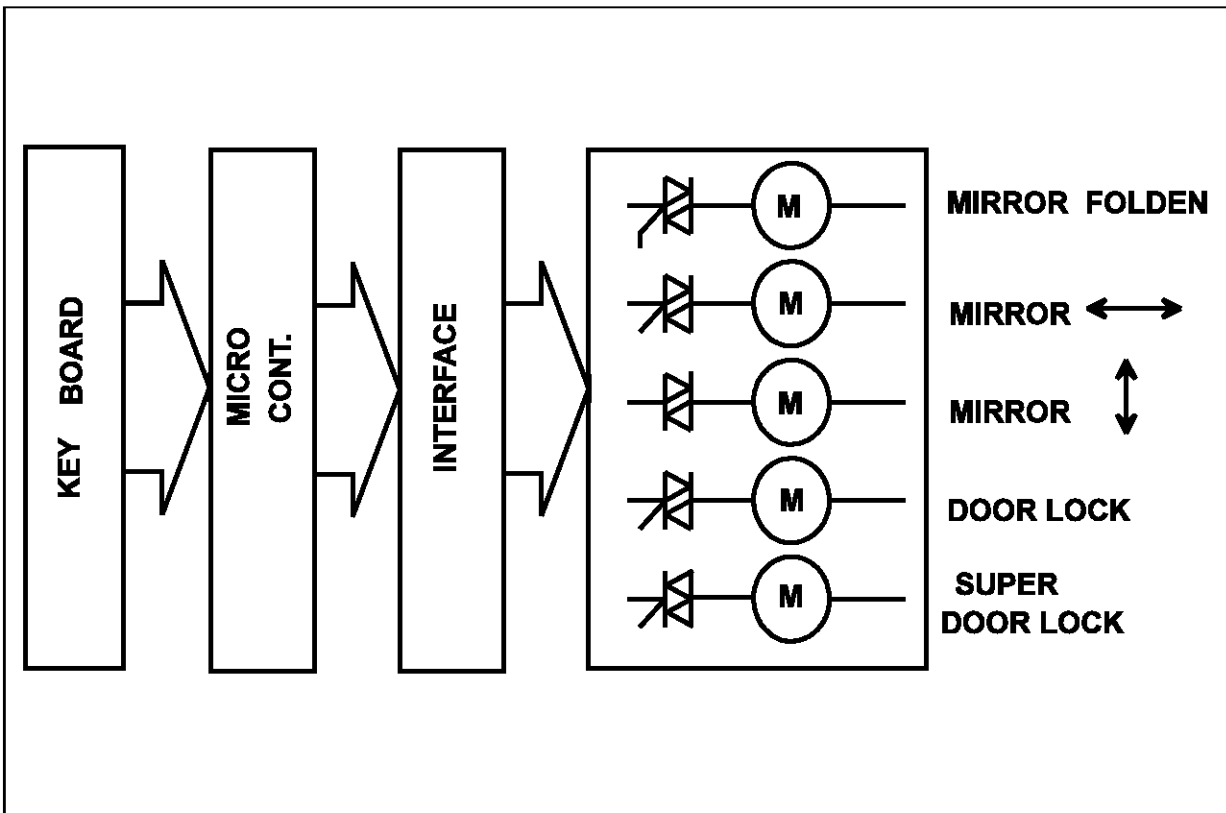

B.3. Other applications

B.3.1. Small motor breaking

Another example of application of SCR or triac in a DC motor circuit is the dynamic breaking. For instance, wipers control requires an accurate positioning when the motor is switched off.

An efficient solution consists in short circuiting the motor, with the SCR T, as soon the circuit is turned off (fig.10). A MOSFET is also able to break but would cause a short circuit with its body diode in case of reverse polarity.

Fig. 10 : Thyristor used in motor breaking

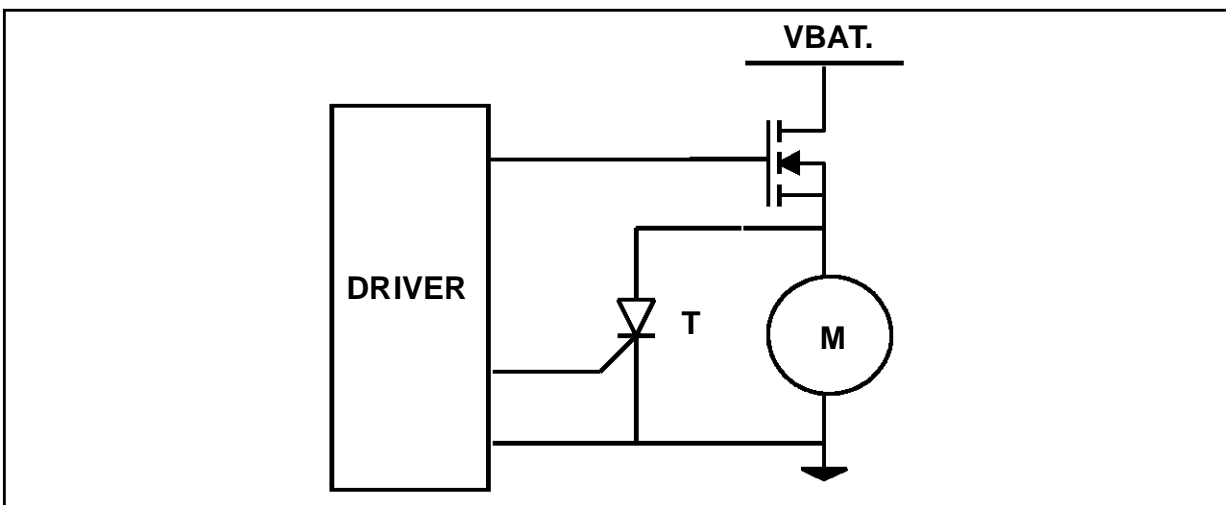

APPLICATION NOTE

B.3.2. High side switch

The major part of switches used in car are N-channel MOSFETS. For the high side switches or for the upper arms of H-bridges as well, an additional specific circuit for the driver must be implemented : auxiliary power supply, charge pump, bootstrap

circuit etc... are needed and therefore increase the circuit complexity and the cost.

We propose the diagram shown in fig.11

Fig. 11 : Sensitive SCR can be used as upper arm of H-bridge. The driver, in this case, is dramatically simplified.

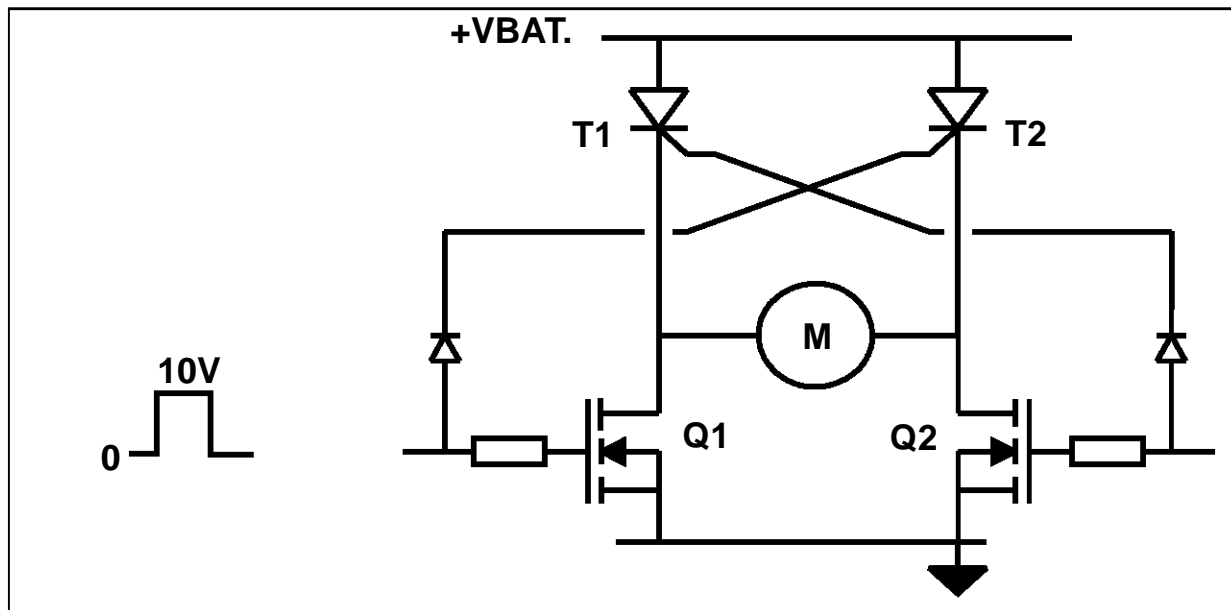

The same logic level signal turns on the MOSFET (Q1) and generates a gate triggering current (through the motor) to the opposite high side thyristor (T2). When the control signal drops to zero, the MOSFET turns off and then the SCR opens.

CONCLUSION

The new generations of SCR's and triacs bring solutions to the increasing demand for a low cost and reliable electronic switch in today's car applications.

The particular characteristics of thyristor offer a powerful and cost effective solution in many applications. The examples presented in this note concerning ignition circuits, door lock control and various motor drives can give new ideas to the designer.

SCR's and triacs are today fully compatible with automotive requirements in terms of quality and reliability. The technology of these structures is in continuous evolution and a new step has been reached with the integration of several "discrete" functions on the same silicon die (ASD™ : Application Specific Discretes).

Some ASD products, dedicated to applications mentioned in this paper, are in development. This development approach opens up a new prospect providing space saving and cost reduction combined with the quality inherent in the planar technology.

APPENDIX

SCR

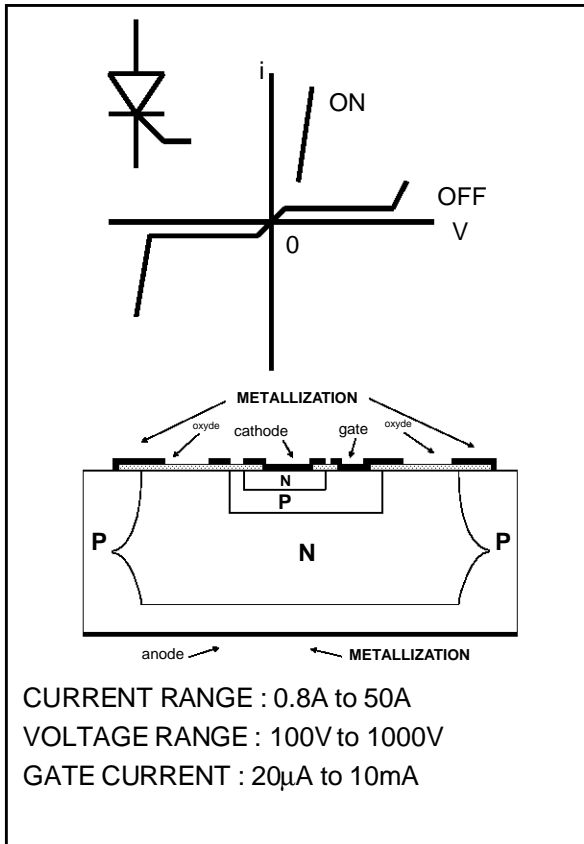

TRIAC

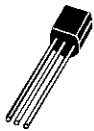
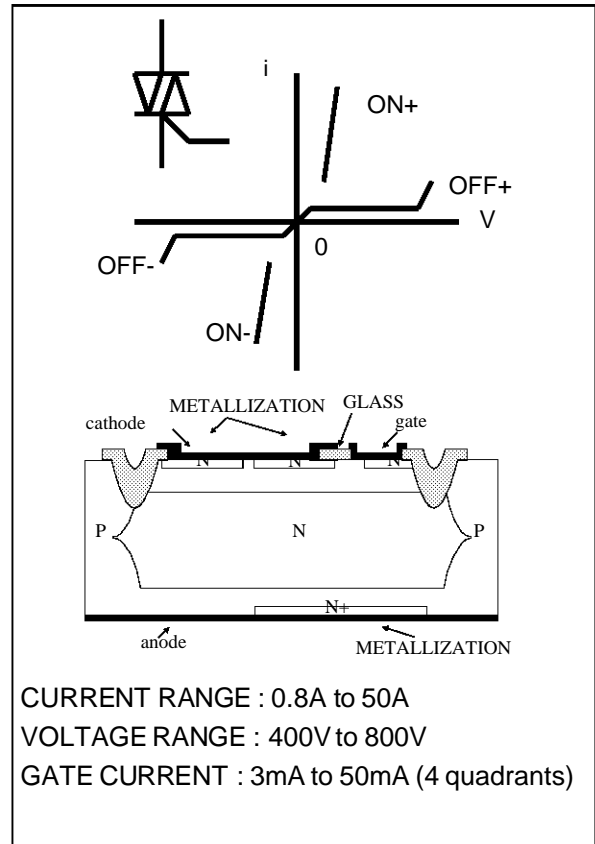

SO92

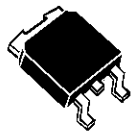

DPAK

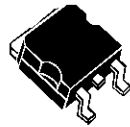

D2PAK

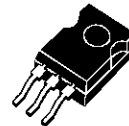

SOT194

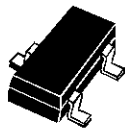

SO23

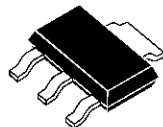

SOT223

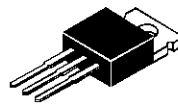

TO220

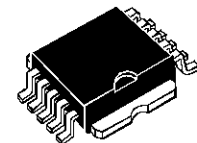

POWERSO-10™

Information furnished is believed to be accurate and reliable. However, SGS-THOMSON Microelectronics assumes no responsibility for the consequences of use of such information nor for any infringement of patents or other rights of third parties which may result from its use. No license is granted by implication or otherwise under any patent or patent rights of SGS-THOMSON Microelectronics. Specifications mentioned in this publication are subject to change without notice. This publication supersedes and replaces all information previously supplied. SGS-THOMSON Microelectronics products are not authorized for use as critical components in life support devices or systems without express written approval of SGS-THOMSON Microelectronics.

© 1997 SGS-THOMSON Microelectronics - Printed in Italy - All rights reserved.

SGS-THOMSON Microelectronics GROUP OF COMPANIES

Australia - Brazil - Canada - China - France - Germany - Hong Kong - Italy - Japan - Korea - Malaysia - Malta - Morocco - The Netherlands - Singapore - Spain - Sweden - Switzerland - Taiwan - Thailand - United Kingdom - U.S.A.