

TRIAC DRIVE CIRCUIT FOR OPERATION IN QUADRANTS I AND III

Ph. RABIER

New triacs with high commutation and dv/dt performances are now available on the market.

Generally these triacs are only triggerable in the 3 first quadrants (case of SNUBBERLESS and LOGIC LEVEL triacs) as shown in figure 1.

This paper describes a trigger circuit supplying a negative gate current for quadrants II and III implemented in a system using a positive power supply.

Without a new design, just by adding a capacitor and a diode new W series triacs can replace conventional triac.

Figure 1 : The quadrants of a W series triac.

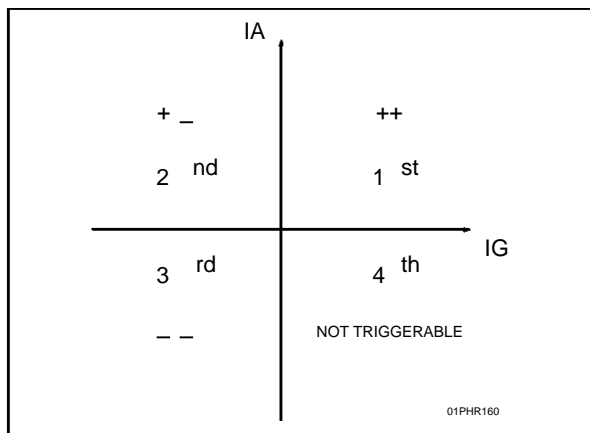

I - PRINCIPLE :

Figure 2 shows the schematic of a system with a sensor, logic and positive power supply (with respect to the anode 1 of the triac).

Figure 2 : Synoptical diagram of a classical system.

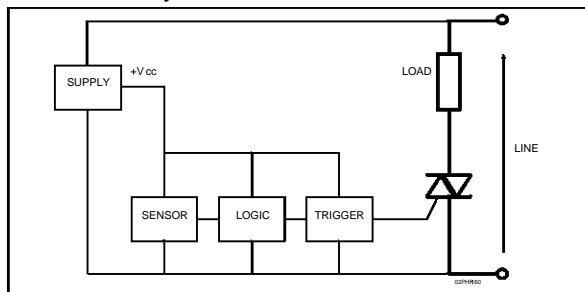

To drive the triac in the 2nd and 3rd quadrants a discharge capacitor is used as shown in figure 3.

Figure 3 : Basic diagram of the trigger.

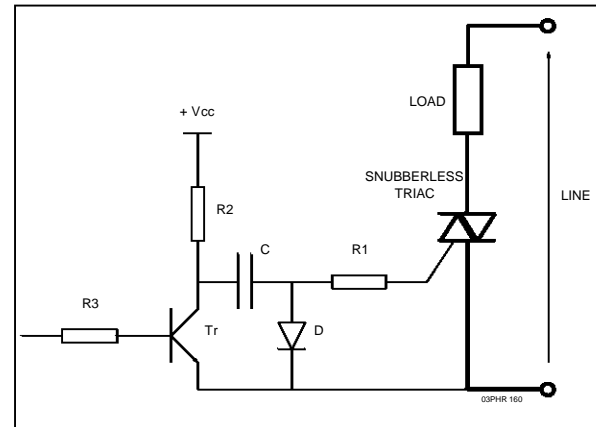

1/ Principle :

- The transistor is switched off, capacitor C is charged through resistance R2 and diode D.

The diode is used to avoid a capacitor load current through the gate of the triac. A schottky diode could be used to improve the voltage drop level lower than the gate non trigger voltage (V_{GD}).

- When the triac is triggered, the transistor Tr is switched on, C is discharged through R1 and Tr and a negative current flows through the gate of the triac.

The capacitor C acts as a differentiation. We have to consider different parameters to define all the components :

- The gate trigger current of the triac (I_{GT})
- The time duration of the gate current
- The latching current (I_L) especially for small or inductive loads.

APPLICATION NOTE

2/ Review :

Définition of the latching current (I_L) :

The I_L of a triac is the minimum value of the main current which allows the component to remain in the conducting state after the gate current I_G has been removed.

That is to say the gate current has to be higher than I_{GT} until the main current reaches the latching current.

Example : for the CW SNUBBERLESS triac :
 Q1 - Q3 : $I_{Lmax} = 50 \text{ mA}$
 Q2 : $I_{Lmax} = 80 \text{ mA}$
 With : gate pulse duration of $20\mu\text{s}$ at $T_j = 25^\circ\text{C}$

I_L max is specified in the CW series triac data sheet.

Statistically, for BW series triacs we can use the K ratio

$$K = I_{Lmax}/I_{GTmax}$$

$$K = 2,3$$

Two solutions are possible :

- Triggering with a delay after zero voltage crossing such that the main current is higher than I_L .
- Triggering at zero voltage crossing with a long discharge time in order to have no problem with I_L .

II - THE CASE WITH A RESISTIVE LOAD :

1/ First solution: delayed pulse current (figure 4).

Figure 4 : Triggering with delay t_1 after zero crossing.

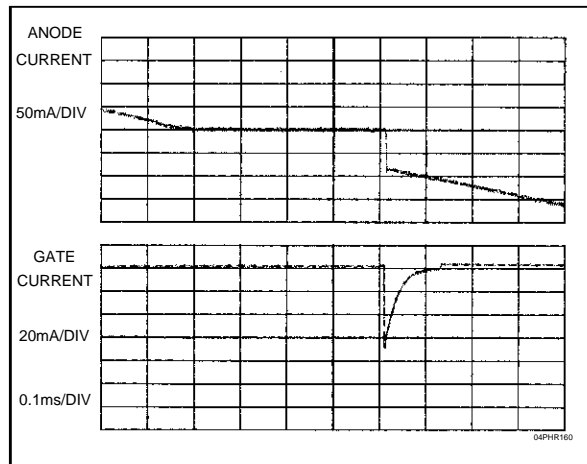

The gate pulse is shown in Figure 5 :

Figure 5 : Gate pulse.

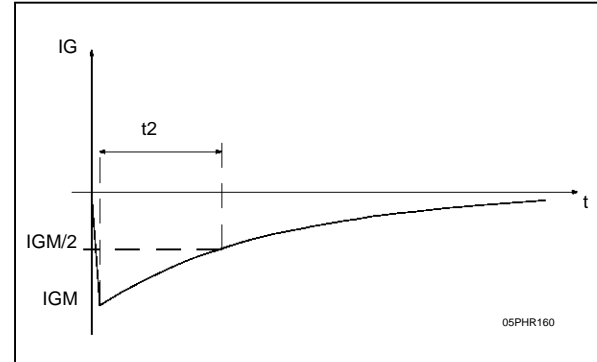

t_1 calculation :

The triac has to be triggered when the main current is higher than the latching current, that is to say t_{1min} is :

$$t_1 = \frac{1}{\omega} \arcsin \left(\frac{I_L \max}{I_{RMS} \sqrt{2}} \right)$$

where $\omega = 2 \cdot \pi \cdot f$

I_{RMS} : minimum RMS current in the worst case (depending on line and load dispersion).

The curve given shows the minimum time versus I_{RMS} current through the anode (figure 6).

Figure 6 : t_1 time versus I_{RMS} for different latching currents.

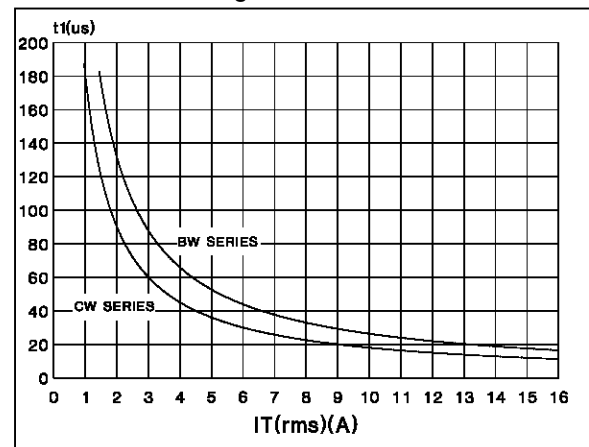

The gate current calculation :

I_{GT} is the maximum gate trigger current specified in the data sheet. To ensure a good safety margin and good triggering we have chosen $I_G = 2 \cdot I_{GT}$ with a pulse duration t_2 higher than $20\mu\text{s}$.

All the components can be defined by the following formulae :

$$R1_{max} = (V_{CC} - V_{GK} - V_{CE}) / (2 \cdot I_{GT})$$

with $V_{GK} = 2 \text{ V}$ at $I_G = 2 \cdot I_{GT}$

$$C_{min} = t2 / (R1 \cdot \log 2) \text{ with } t2 = 20 \mu s$$

$$R2_{max} = 0,001 / C$$

Curve 7 gives the minimum capacitance versus supply voltage for different sensitivity.

Figure 7 : Capacitance value versus supply voltage for different sensitivity.

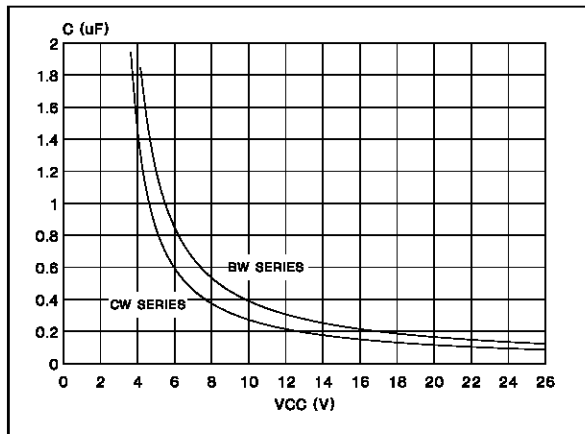

In this way the RMS current is lower than the full wave current, the RMS current/full wave current ratio is :

$$K^2 = 1 - 2 \cdot \frac{t1}{T} + \frac{1}{2\pi} \cdot \sin \left(4 \pi \frac{t1}{T} \right)$$

The calculation gives for a 6 Amps CW triac with a 2 Amps sine current and with an $I_L = 80 \text{ mA}$.

$$t1 = 90 \mu s$$

$$K = 0,99$$

That means the losses are lower than 1%.

2/ Second solution : Wide current pulse at zero crossing.

It consists of triggering the triac at zero voltage crossing voltage as shown in figure 8.

Figure 8 : Triggering at zero voltage.

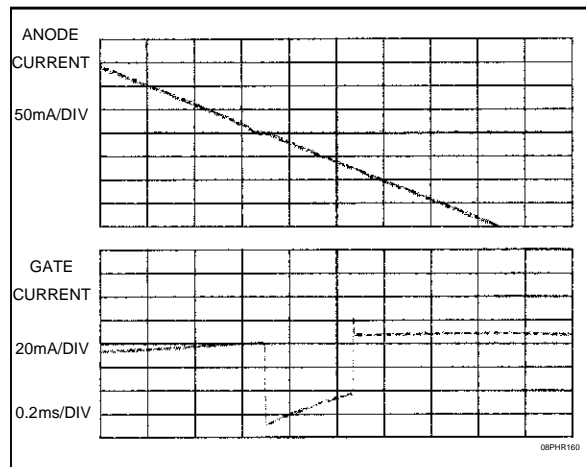

Note : In figure 8, the pulse through the transistor base is cancelled before the capacitor is fully discharged to save energy.

All the components can be defined by the following formulae :

$$t2_{min} = \frac{1}{\omega} \arcsin \left(\frac{I_L}{I_{RMS} \sqrt{2}} \right) + 20 \mu s$$

$$R1_{max} = (V_{CC} - V_{GK} - V_{CE}) / (2 \cdot I_{GT})$$

$$C_{min} = t2 / (R1 \cdot \log 2)$$

$$R2_{max} = 0,001 / C$$

In this way the RMS current is equal to the full wave current.

APPLICATION NOTE

3/ Comparison between these two solutions :

The calculation of all the components is shown in the following table for 3 different cases

Figure 9 : Component values for 3 different cases : triac used : BTA08-600CW ($I_{GT} = 35 \text{ mA}$)

| | $I_{RMS} = 5 \text{ A}$ $V_{CC} = 10 \text{ V}$ | | $I_{RMS} = 2 \text{ A}$ $V_{CC} = 5 \text{ V}$ | | $I_{RMS} = 5 \text{ A}$ $V_{CC} = 5 \text{ V}$ | |
|--------------------------|--|------------------|---|------------------|---|------------------|
| | with delay | at zero crossing | with delay | at zero crossing | with delay | at zero crossing |
| t1 min (μs) | 36 | 0 | 91 | 0 | 36 | 0 |
| t2 min (μs) | 20 | 56 | 20 | 111 | 20 | 56 |
| R1 max (Ω) | 105 | 105 | 34 | 34 | 34 | 34 |
| C min (μF) | 0.275 | 0.77 | 0.85 | 4.7 | 0.85 | 2.37 |
| R2 max (Ω) | 3.7 | 1.3 | 1.18 | 0.212 | 1.18 | 0.42 |

III - CASE OF INDUCTIVE LOAD :

With an inductive load another problem occurs : the problem of the phase lag between load current and load voltage.

It can be solved by taking into account :

- the maximum phase lag to define a delay time t_d .
- the latching current to define the time t_1
- the inductance to define the time $t_2 = V/L$ at the moment when the triac is fired ($t_2 > 20\mu\text{s}$) to have an anode current higher than the latching current I_L .

The figure 10 shows the anode current and the gate current in the triac, in the case of an inductive load.

Figure 10 : Current through an inductive load.

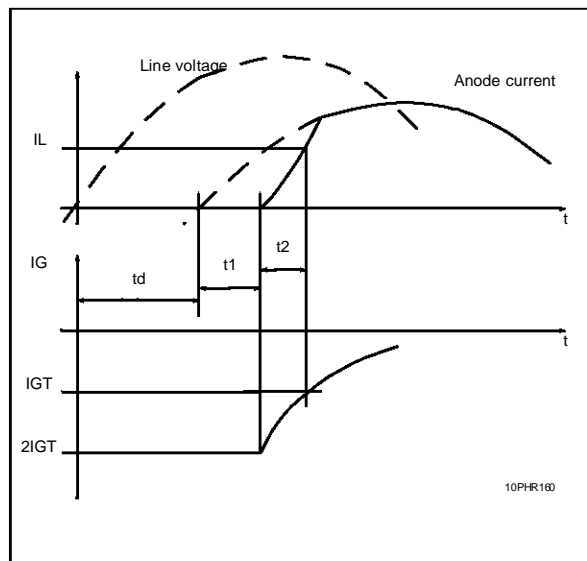

If the phase lag is not constant a gate pulse train can be used, the calculation parameters are the same, except for R2 : the capacitor C has to be charged between 2 pulses so the equation is :

$$R2 = (\text{time between 2 pulses}) / (5 \times C)$$

IV - THE CASE OF A SMALL LOAD :

This trigger circuit can not be effectively used to drive small loads (like valves, fan etc...) because the latching current value is not very small compared to the load current. In this case a DC gate current is needed.

V - CONCLUSION :

In the case of controllers supplied by positive voltage this solution allows of the replacement of conventional triacs used in the 1st and 4th quadrants by SNUBBERLESS or LOGIC LEVEL triacs triggerable only in the 3 first quadrants without a new design but only by adding a capacitor and a diode.

Two configurations are possible :

First solution : Triggering after the zero voltage crossing.

Advantage : capacitor value lower than $1\mu\text{F}$.
Disadvantage : the need to have a delay after the zero voltage crossing (delay system needed).

Second solution : Triggering at zero voltage crossing.

Advantage : 100% of the power used in the load.
Disadvantage : capacitor value of a few microfarads.

With inductive loads (motor, transformer, etc...) a pulse train can be used because of the phase lag between current and voltage.

With small loads (valve, fan,...) a DC gate current has to be used to drive the triac because of the latching current.

In case of logic or transistor failure, the capacitor C operates as an open circuit for DC current and avoids all triggering. This factor acts as a safety feature.

Information furnished is believed to be accurate and reliable. However, SGS-THOMSON Microelectronics assumes no responsibility for the consequences of use of such information nor for any infringement of patents or other rights of third parties which may result from its use. No license is granted by implication or otherwise under any patent or patent rights of SGS-THOMSON Microelectronics. Specifications mentioned in this publication are subject to change without notice. This publication supersedes and replaces all information previously supplied.

SGS-THOMSON Microelectronics products are not authorized for use as critical components in life support devices or systems without express written approval of SGS-THOMSON Microelectronics.

© 1995 SGS-THOMSON Microelectronics - Printed in Italy - All rights reserved.

SGS-THOMSON Microelectronics GROUP OF COMPANIES

Australia - Brazil - France - Germany - Hong Kong - Italy - Japan - Korea - Malaysia - Malta - Morocco -
The Netherlands - Singapore - Spain - Sweden - Switzerland - Taiwan - Thailand - United Kingdom - U.S.A.