

Design of Isolated Converters Using Simple Switchers

Introduction

Isolated converters are required to provide electrical isolation between two interrelated systems. Isolation between the power source and the load is required in certain applications in order to meet safety specifications such as UL1459, which necessitates 500V of isolation for telecom applications.

Isolation must be provided between all the input and output stages of the power converter. Thus, isolation must be provided in the power stage and the control loop. Power stage isolation is generally provided using transformer. Isolation in the feedback/control loop is often provided through an opto-coupler (also known as opto-isolator).

Transformers are well suited for power stage isolation, since they are known for providing good dielectric barrier between two systems, with the ability to have multiple outputs. Transformers also allow stepping up or stepping down of the input voltage.

In isolated switching power supplies, opto-couplers are very widely used to provide isolation in the feedback loop. Opto-couplers do an excellent job of isolation, minimizing circuit complexity and reducing cost. One of the disadvantages of using an opto-coupler is its low bandwidth. The bandwidth of the converter is reduced by the introduction of an extra pole in the control loop gain of the converter. This is not a problem in conventional low frequency converters. However, in modern high-frequency converters, the opto-coupler imposes severe restrictions on control loop bandwidth/speed.

Another disadvantage of using opto-isolator is the large unit-to-unit variation in the current transfer ratio (CTR). CTR or the coupling efficiency is defined as the ratio of opto-isolator transistor collector current to the diode current. The loop gain is directly proportional to CTR gain. Hence, high variation in CTR imposes constraints on control loop design.

Part I. Design of Opto-Isolated Power Supply

DESIGN APPROACH

With the advent of SIMPLE SWITCHER™, and the associated “Switchers Made Simple” software (SMS4.2.1, SMS3.3), the non-isolated converter design has become very simple. However, the non-isolated converters can be modified to isolated converters very easily. The procedure for design of opto-isolated converter is as follows:

Step 1: Design the power stage components for a flyback converter using SMS4.2.1/3.3. The “Switchers Made Simple” software can be used to design the transformer, input/output capacitors, output rectifier, clamping network, etc.

Step 2: Modify the feedback/control loop by introducing a secondary side controller (such as LM3411) and an opto-isolator for feedback isolation. Also, disable the internal reference in the Simple Switcher.

National Semiconductor
Application Note 1095
Ravindra Ambatipudi
August 1998



DESIGN OF POWER STAGE COMPONENTS

The first step in the design process is to enter the converter specifications (shown in *Table 1*) in the input menu of the “Switchers Made Simple” software. Using these specifications, the software will design the power stage components. The following example will be based on Switchers Made Simple 4.2.1 (SMS4.2.1) and the associated LM258X flyback converters.

If the input specifications are entered as shown in *Figure 1*, SMS4.2 will design a buck converter instead of flyback. In order to design a flyback converter when the output voltage is lower than input voltage levels, it is necessary to enter initially a fictitious output voltage value which is greater than $V_{IN(min)}$. The software will then design a flyback. Now, go to the main menu and change input requirements. Change the fictitious output voltage value to the required value. If the output voltage is greater than the minimum input voltage, these extra steps are not necessary.

TABLE 1. Isolated Power Converter Specifications (Example)

Input Voltage	10V to 30V
Output Voltage	5V
Load (maximum)	2A
Operating Temp. Range	0°C to 70°C

Num Outputs = 1
 V_{IN} Min = 10.00V
 V_{IN} Max = 30.00V
 V_{OUT1} = 5.00V
 I_{OUT1} Max = 2.00A
 $V_{RIPPLE1}$ = 0.10V
 T_A Min = 0.00°C
 T_A Max = 70.00°C

Ok Cancel

10015101

FIGURE 1. Enter the Converter Specifications in the Input Menu of SMS4.2.1

Modify the component values, input specs, etc. to suit the requirements. The software will design all the power stage components and give a list of vendors. In the example shown in *Figure 2*, the component values were entered manually to produce a surface mount design.

The isolation voltage of the transformer is not listed in the software. The isolation voltage is generally mentioned in the

Part I. Design of Opto-Isolated Power Supply (Continued)

transformers listed in the LM258X Simple Switcher data sheets meet UL1459 spec, and are suitable for telecom applications.

transformer manufacturer's catalog. Select a transformer taking into consideration the isolation voltage. Any of the

Input Parameters		Operating Values		Component Values	
V_{IN} Min	= 10.00V	Mode	= Cont	Pri L	= 22.00 μ H
V_{IN} Max	= 30.00V	Frequency	= 100.00 kHz	Leakage L	= 470.00 nH
V_{OUT1}	= 5.00V	Duty Cycle	= 38.68%	N1 sec/pri	= 1.00
I_{OUT1} Max	= 2.00A	IC I_{PK} Max	= 5.00A	V_Z	= 20.00V
$V_{RIPPLE1}$	= 0.10V	IC I_{PK}	= 4.04A	C_{IN}	= 560.00 μ F
T_A Min	= 0.00°C	L I_{PP}	= 1.56A	C_{IN} ESR	= 40.00 m Ω
T_A Max	= 70.00°C	Efficiency	= 72.88%	C_C	= 1.00 μ F
		IC Pd	= 1.71W	R_C	= 1.00 k Ω
		IC T_J	= 106.21°C	IC Heatsnk	= 19.23°C/W
		Diode1 Pd	= 1.00W	Pri DCR	= 35.84 m Ω
		Xformer Pd	= 0.32W	C_{OUT1}	= 660.00 μ F
		Zener Pd	= 0.49W	C_{OUT1} ESR	= 24.00 m Ω
		I_N Avg	= 1.37A		
		Cross Freq	= 2.40 kHz		
		Phase Marg	= 89.78 Deg		
		V_{OUT1} P-P	= 96.61 mV		

10015102

FIGURE 2. Main Screen of SMS4.2.1 Summarizes the Design

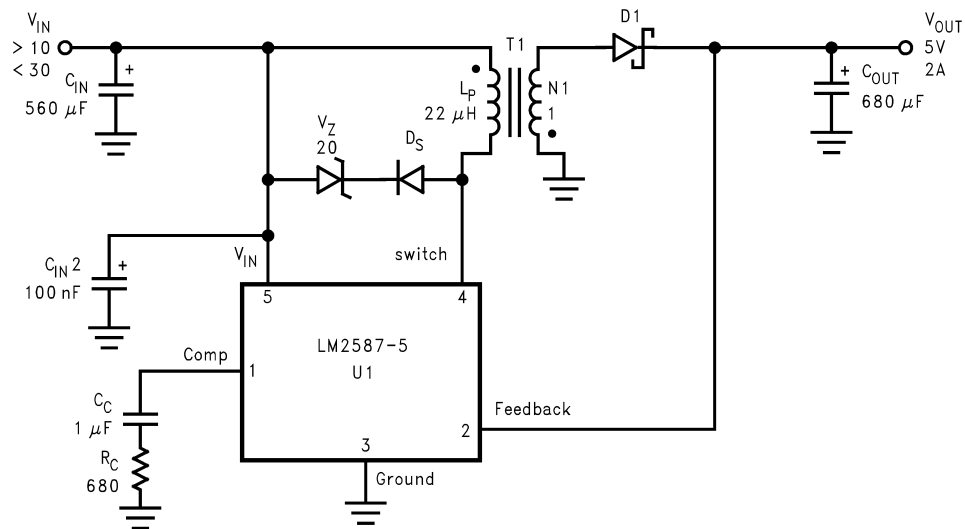

10015103

FIGURE 3. Circuit Designed using SMS4.2.1

The software will also produce a schematic of the non-isolated converter as shown in Figure 3. This concludes the first step of the design process.

Part I. Design of Opto-Isolated Power Supply (Continued)

MODIFICATION OF CONTROL LOOP FOR ISOLATED DESIGN

The second step in designing an opto-isolated converter is to modify the feedback loop by using a secondary controller such as LM3411 and to use an opto-isolator for feedback

isolation. To do this, connect an opto-coupler between the secondary controller and the compensation pin for feedback isolation. Power stage isolation is provided by the transformer.

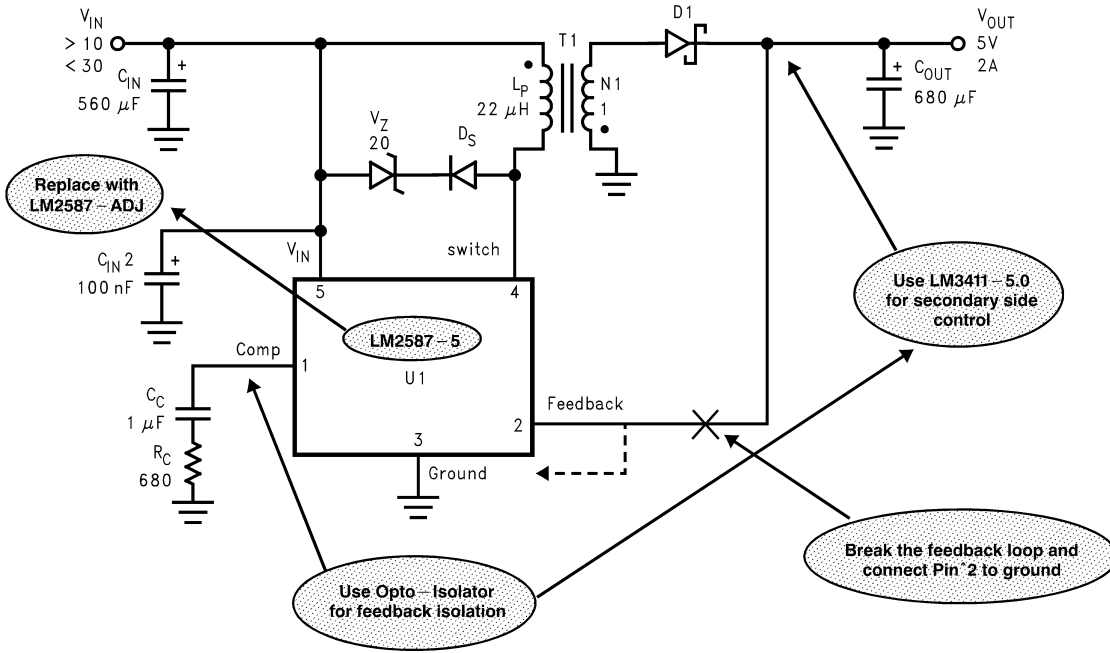

10015104

FIGURE 4. Modification of Non-Isolated Flyback to Isolated Flyback

The reference and the error amplifier internal to LM2587 have to be disabled in order to avoid interaction with the reference in secondary controller and to avoid excessive gain in the feedback loop. Figure 5 shows the internal block diagram of LM2587. By connecting the feedback pin to

ground and by connecting the opto-coupler output to the compensation pin, the error-amp is by-passed. For this reason, any voltage option of the LM2587 can be used. This completes the design of the isolated converter.

Part I. Design of Opto-Isolated Power Supply (Continued)

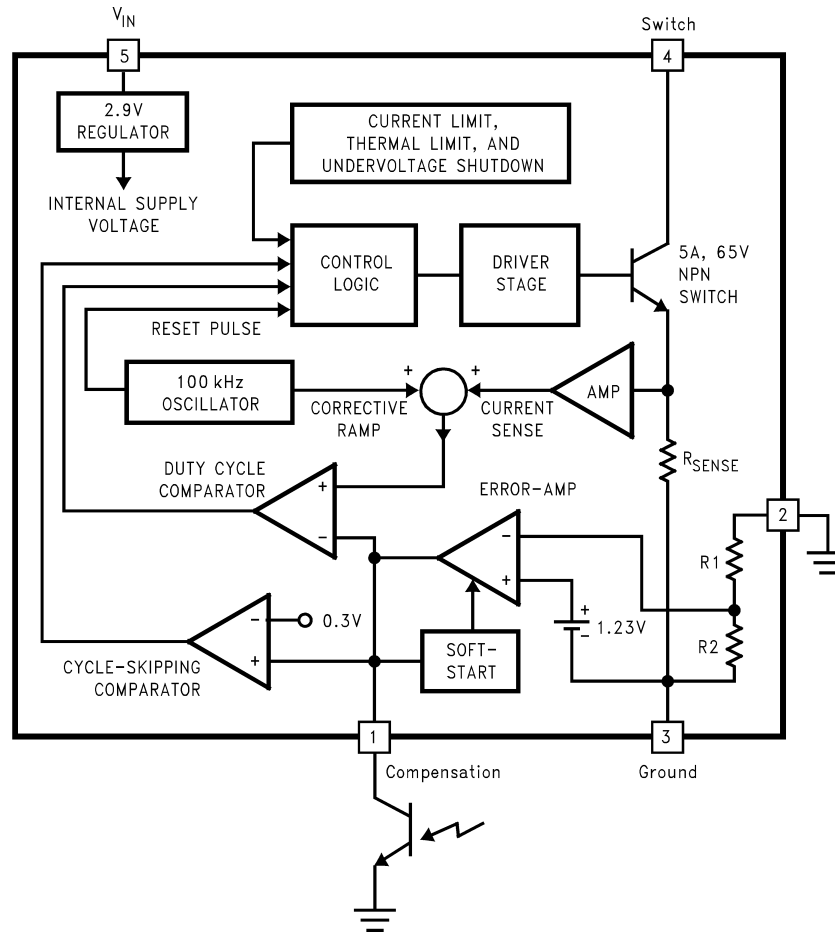

10015105

FIGURE 5. LM2587 Block Diagram; Grounding Feedback Pin Disables Error Amplifier, Opto-Coupler Delivers Feedback to Compensation Pin Instead

Figure 6 shows the circuit diagram of an LM2587 based opto-isolated flyback power supply. With the LM2587 error amplifier disabled, the feedback control now consists of LM3411-5.0 secondary side controller and the opto-isolator. Resistors R_o and R_d are required for biasing the opto-isolator. Capacitor C_s is required for soft-start.

Note: Short Circuit Protection. In LM258X switchers, the soft-start comparator and the short-circuit protection are both controlled by the feedback pin voltage. At start-up, when the output voltage is zero, the

soft-start comparator is activated and the output gradually increases to the nominal value. After this, the soft-start comparator gets disabled and the short-circuit protection is enabled. Now if the output is shorted, the frequency will change to 25% of normal operating frequency.

The short-circuit protection is activated only after the soft-start is disabled. In the isolated converter, the feedback pin is grounded. The converter never comes out of soft-start mode. So the short-circuit protection (which changes the frequency to 25 kHz under short circuit conditions) never gets activated. Hence, an external circuit is required for short-circuit protection.

Part I. Design of Opto-Isolated Power Supply (Continued)

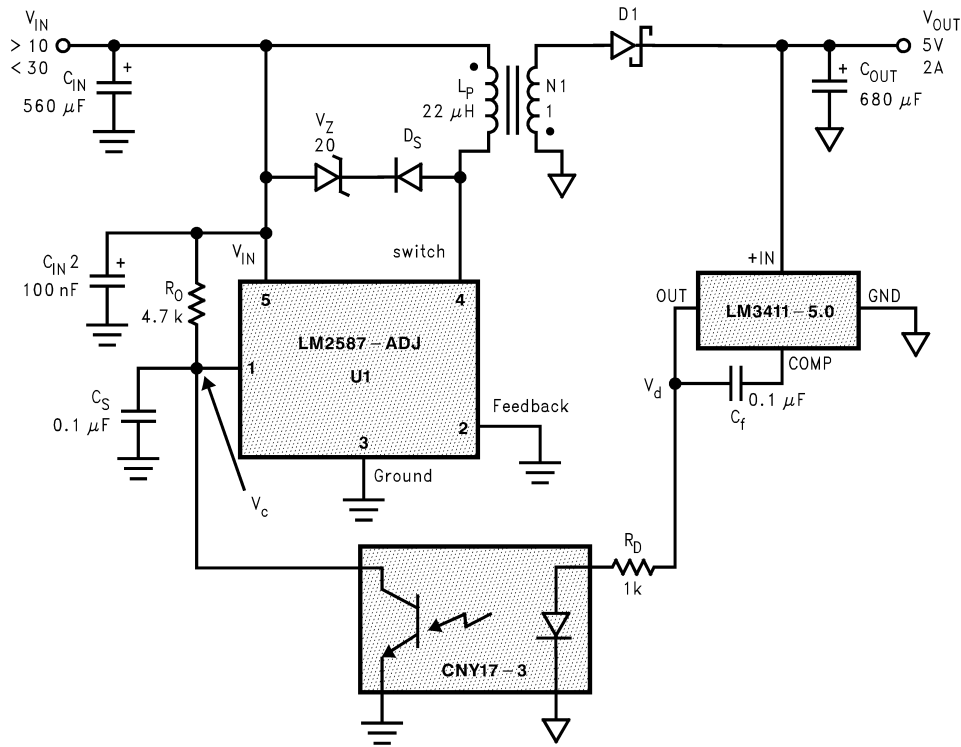

10015106

FIGURE 6. 10 Watt Opto-Isolated Flyback Converter

SELECTION OF COMPENSATION COMPONENTS

The compensation circuit design involves selection of the opto-coupler output resistance, R_o , the opto-coupler input resistance, R_i , and the feedback capacitance, C_f . The compensator transfer function is the small-signal transfer function from the output voltage, V_o to the control voltage, V_c . The transfer function, $A(s)$ is given by:

$$A(s) = \frac{CTR \times R_o}{R_d} \left(1 + \frac{1}{sC_f R_i} \right)$$

Thus, the compensator is a two pole, one zero compensator. In the above equation, CTR is the opto-coupler current transfer ratio or coupling-efficiency. The power stage transfer function is a one pole, one zero (esr) compensator (in the frequency range of interest). Choose R_o and R_d such that voltage V_c is always more than 0.3V. Also, the maximum voltage on the compensation pin should be no more than 2V.

Choose C_f to place a zero to cancel the power stage pole, as shown in Figure 7. If the compensator is designed as shown above, the loop gain should have very good phase margin and gain margin. In Figure 7,

$$f_z = \frac{1}{2\pi C_f R_i}, \quad f_{p1} = \frac{1}{2\pi C_o R_L}$$

$$f_{esr} = \frac{1}{2\pi C_o R_{esr}}$$

where f_{p1} is the frequency of the power stage pole in current mode converter, f_z is the compensator zero, and f_{esr} is the esr zero. f_c is the loop cross over frequency. f_{p2} is the pole(s) created due to current mode control (located at high frequencies close to half the switching frequency).

Part I. Design of Opto-Isolated Power Supply (Continued)

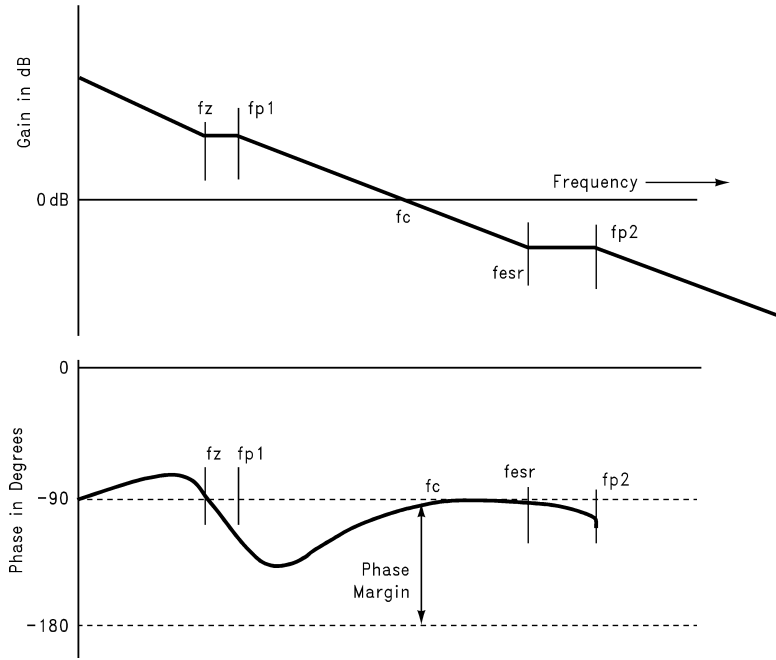

10015109

FIGURE 7. The Estimated Loop Response

The loop gain measured on the experimental converter shown in Figure 6, is shown in Figure 8. The bandwidth and phase margin are very much lower than expected.

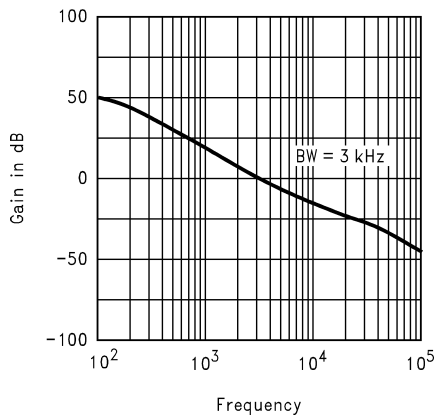

10015110

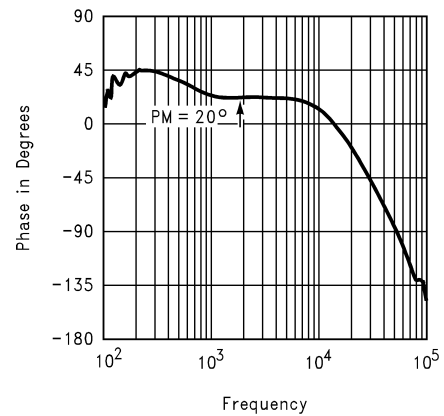

10015111

FIGURE 8. Measured Loop Gain of the Experimental Converter (Bandwidth = 3 kHz and Phase Margin = 20°)

Since the bandwidth and phase margin are very low, a transient step of 0 to 1A produces a very poor transient response, as shown in Figure 9. This also indicates poor stability in the control loop.

Part I. Design of Opto-Isolated Power Supply (Continued)

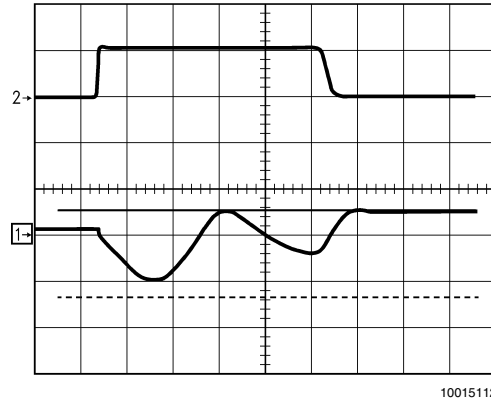

FIGURE 9. Transient Response for a Step Change in Load from 0 to 1A

Part II. Improving Transient Response of Opto-Isolated Converters

WHAT CAUSES THE DIVERGENCE BETWEEN ESTIMATED AND MEASURED RESULTS?

The converter shown in *Figure 6* uses an opto-isolator CNY17-3 for feedback isolation and LM3411 for secondary side control. Since this converter is operated at 100 kHz

switching frequency, then it is desired to have its loop cross-over at around 10 kHz–20 kHz for superior transient performance. However, the opto-coupler CNY17-3 used in this configuration has a -3 dB frequency of 5 kHz–10 kHz depending on the resistance R_o shown in *Figure 6*. The opto-coupler pole will introduce a phase-shift of more than 45° at around 10 kHz as shown in *Figure 10*. Because this fact was not taken into consideration while designing the compensator or loop gain, the measured phase margin and the bandwidth are lower than what was estimated.

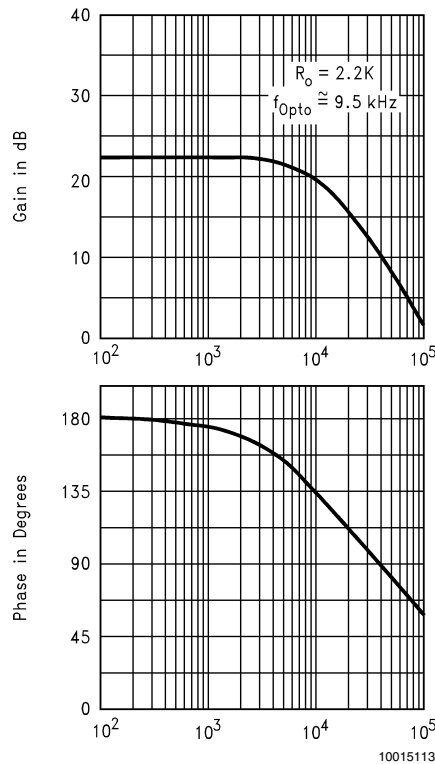

FIGURE 10. Opto-Coupler CNY17-3 Adds More Than 45° of Phase Shift at the Desired Loop Bandwidth of 10 kHz

Part II. Improving Transient Response of Opto-Isolated Converters (Continued)

WHAT LIMITS THE BANDWIDTH OF THE OPTO-COUPLER?

The severe bandwidth limitations of the opto-coupler is due entirely to the characteristics of the opto-coupler photo-transistor. When forward current is passed through the opto-coupler diode, it emits infra-red radiation. This radiant energy

is transmitted through an optical coupling medium and falls on the surface of the photo-transistor. In order to make the photo-transistor base region sensitive to light, and to minimize the losses in radiant energy transfer, the photo-transistors are designed to have a very large base-collector junction area and a very thick base region. This results in a very large base capacitance, C_{ob} . This capacitance is typically in the order of several pico farads. However, this gets effectively multiplied due to the Miller effect, resulting in a very large Miller capacitance C_{om} . The Miller capacitance is in the order of several nana farads.

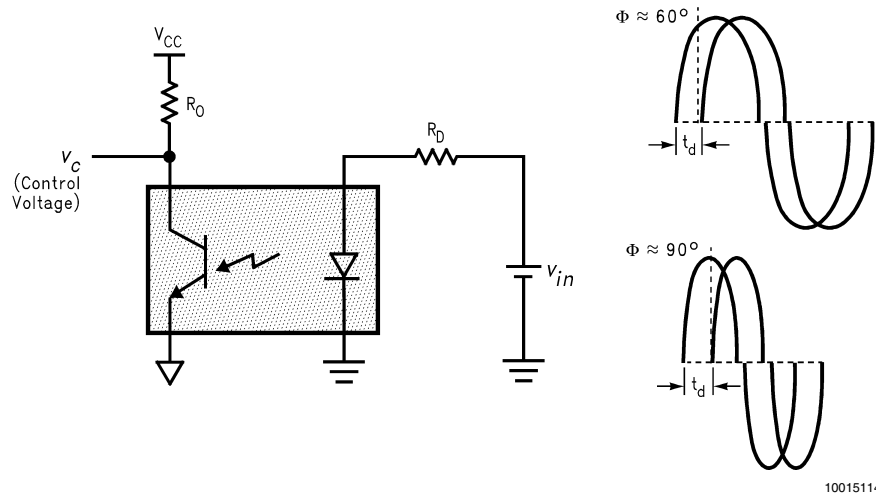

FIGURE 11. Opto-Coupler Transmission Delay Adds Phase Change at High Frequencies (as the frequency of the input sinusoid increases, the phase shift between the input and output increases linearly)

The Miller capacitance C_{om} , coupled with the resistance R_o , will produce a pole in its transfer function. This pole should be taken into consideration while designing the compensation circuit.

It can also be observed from the opto-isolator characteristics that the phase changes very dramatically at very high frequencies. This is due to the inherent delay in transmission of radiant energy through the optical medium. If the input signal to the opto-coupler, as shown in *Figure 11*, is a sinusoid, the output signal is also a sinusoid, but phase shifted due to the delay. As the frequency of this sinusoid increases, the phase shift increases, almost linearly. The phase shift will increase linearly only if this shift is due to time delay.

HOW TO SOLVE THE OPTO-COUPLER BANDWIDTH PROBLEMS?

The control loop bandwidth can be improved in three ways:

1. The phase margin can be improved by reducing the system cross-over frequency. However, the transient performance of the converter is sacrificed.

2. Opto-isolators with better frequency characteristics (such as MOC8101) can be used. However, these opto-couplers are more expensive.
3. The opto-isolator pole can be compensated by introducing an additional zero in the control loop. This requires proper prediction of opto-coupler pole.

ESTIMATION OF THE OPTO-COUPLER POLE

The opto-coupler pole can be estimated in a number of ways. One method is to characterize the pole by actual bench measurements. *Figure 12* shows the bench measurement setup for characterization of an opto-coupler using a network analyzer. A signal is injected at the opto-coupler input and frequency of this signal is swept over the frequency range of interest. The input signal is measured with probe A and the output signal with probe B. By taking the ratio of the input signal to the output signal, the frequency characteristics are obtained.

Part II. Improving Transient Response of Opto-Isolated Converters (Continued)

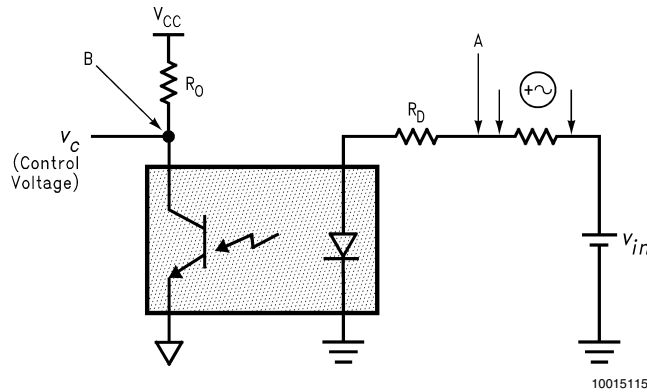

FIGURE 12. Bench Measurement Setup for Frequency Characterization of Opto-Coupler Pole Using a Network Analyzer

Figure 13 shows the typical performance curve obtained by actual measurements for the opto-coupler CNY17-3. In this figure, the opto-coupler bandwidth (pole) has been plotted versus the resistance R_o . The opto-coupler pole can be very easily predicted from this curve. As an example, let us

predict the pole for CNY17-3 when the resistance, $R_o = 5 \text{ k}\Omega$. Draw a line parallel to Y-axis at $R_o = 5 \text{ k}\Omega$. From the point of intersection on the curve, read the corresponding value on Y-axis. The opto-coupler pole would be at 4 kHz.

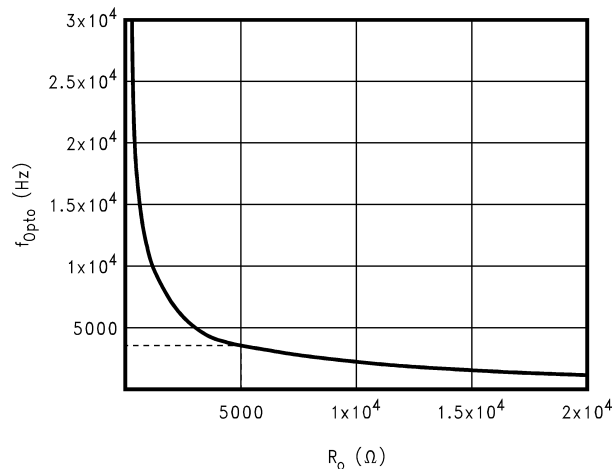

FIGURE 13. Opto-Coupler CNY17-3 Bandwidth versus Resistance R_o

From the results of Part I, it is very obvious that the opto-isolator pole imposes severe restrictions on the control loop bandwidth. This pole can be compensated in two ways:

- If the base connection is available, then by connecting a large resistor between the base and emitter of the opto-coupler photo-transistor, the bandwidth can be improved. However, the opto-coupler gain will reduce by doing so.
- The bandwidth can also be improved by introducing an additional zero in the compensation circuit.

IMPLEMENTATION OF THE OPTO-COUPLER POLE COMPENSATION

For the circuit shown in Figure 6, the opto-coupler pole can be estimated as discussed in previous sections. However, the soft-start capacitor appears in parallel with opto-coupler device capacitances and influences the position of the opto-coupler pole. The additional zero required to compensate the opto-coupler pole can be obtained by connecting a capacitor in parallel with R_{d1} as shown in Figure 14. In the process, this creates an additional pole due to R_{d2} and C_d . To obtain sufficient gain margin and attenuation of high frequency switching noise, this pole can be placed at a high frequency above the cross-over frequency.

Part II. Improving Transient Response of Opto-Isolated Converters (Continued)

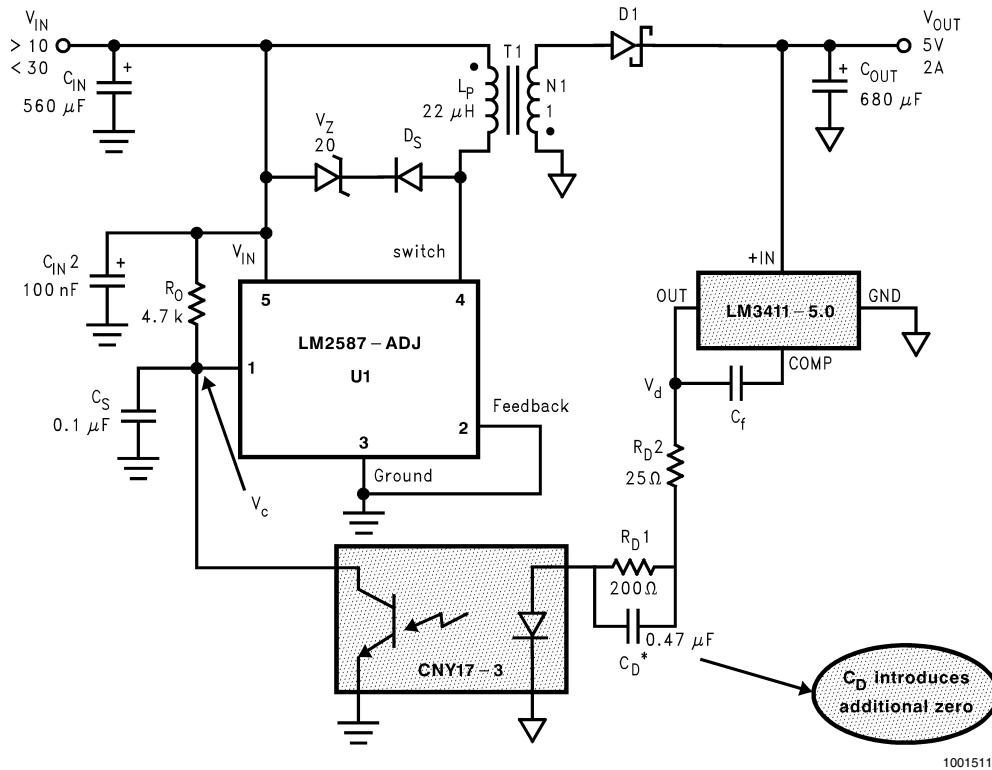

FIGURE 14. Compensating the Opto-Coupler Pole to Improve the Bandwidth Limitations

The modified compensator transfer function is:

$$A(s) = \frac{CTR \times R_o}{R_{d1} + R_{d2}} \left(\frac{sC_c R_f + 1}{sC_c R_f} \right) \left(\frac{sC_d R_{d1} + 1}{sC_d R_{d2} + 1} \right) \quad (\text{assuming } R_{d2} \gg R_{d1})$$

where:

CTR = Opto-coupler current transfer ratio or coupling efficiency

R_f = feedback resistor internal to LM3411 (92k for LM3411-5.0)

C_c = Compensation capacitor

An additional zero can also be obtained by connecting a resistor in series with capacitor *C_s*, the additional zero required to compensate the opto-coupler pole can be placed at a frequency equal to *f_z*.

$$f_z = \frac{1}{2\pi R_o C_s}$$

(Assuming *C_s* is very much larger than the opto-coupler Miller capacitance).

Notice that the compensator transfer function is directly dependent on the opto-coupler *CTR*, which varies from unit-to-unit, so it is important to take this factor into consideration. This means that an opto-coupler with low *CTR* variation and guaranteed limits should be used.

Figure 15 shows the loop gain with modified compensator. Significant improvement in bandwidth and phase margin are observed. The loop gain is as expected and shows excellent stability. As expected, the transient response is also improved, as shown in Figure 16.

Part II. Improving Transient Response of Opto-Isolated Converters (Continued)

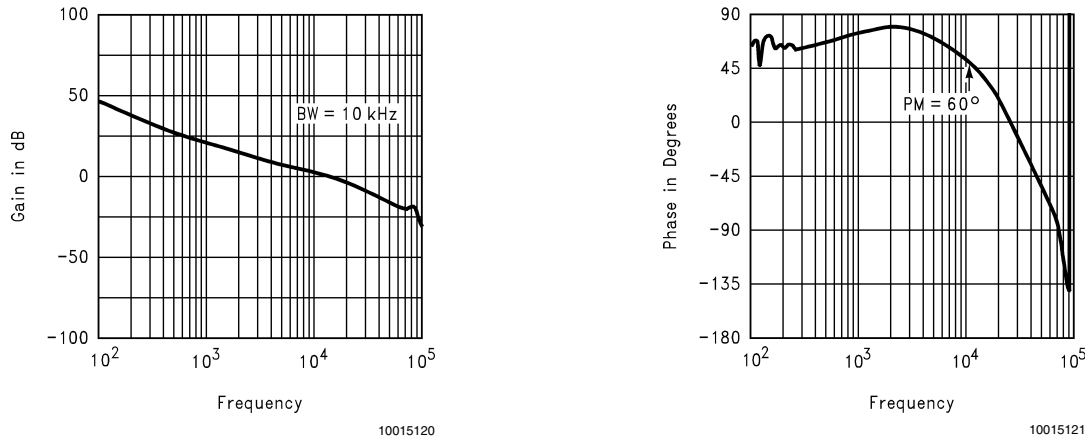

FIGURE 15. Significant Improvement in Bandwidth and Phase Margin is Observed with Opto-Coupler Pole Compensation (Bandwidth = 10 kHz and Phase Margin = 60°)

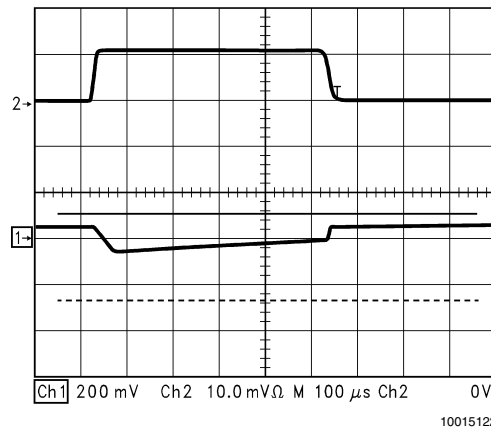

FIGURE 16. Transient Response with Opto-Coupler Pole Compensation (0 to 1A Step-Change in Load)

LIFE SUPPORT POLICY

NATIONAL'S PRODUCTS ARE NOT AUTHORIZED FOR USE AS CRITICAL COMPONENTS IN LIFE SUPPORT DEVICES OR SYSTEMS WITHOUT THE EXPRESS WRITTEN APPROVAL OF THE PRESIDENT AND GENERAL COUNSEL OF NATIONAL SEMICONDUCTOR CORPORATION. As used herein:

1. Life support devices or systems are devices or systems which, (a) are intended for surgical implant into the body, or (b) support or sustain life, and whose failure to perform when properly used in accordance with instructions for use provided in the labeling, can be reasonably expected to result in a significant injury to the user.
2. A critical component is any component of a life support device or system whose failure to perform can be reasonably expected to cause the failure of the life support device or system, or to affect its safety or effectiveness.

National Semiconductor Corporation
Americas
Email: support@nsc.com

National Semiconductor Europe
Fax: +49 (0) 180-530 85 86
Email: europe.support@nsc.com
Deutsch Tel: +49 (0) 69 9508 6208
English Tel: +44 (0) 870 24 0 2171
Français Tel: +33 (0) 1 41 91 8790

National Semiconductor Asia Pacific Customer Response Group
Tel: 65-2544466
Fax: 65-2504466
Email: ap.support@nsc.com

National Semiconductor Japan Ltd.
Tel: 81-3-5639-7560
Fax: 81-3-5639-7507

www.national.com